

# HE1B/2B/3B/5B

## Enabling Switches

# HE1G

## Grip Switch



# What is an enabling switch?

Because operators use teach pendants in hazardous environments performing teaching, system changeover, and maintenance of robots, they must have protection against unpredictable motion of robots, and therefore teach pendants are equipped with 3-position enabling switches.

An enabling switch is a 3-position (OFF-ON-OFF) switch to allow a machine operation only when the switch is lightly pressed and held in the mid position (position 2). Because it disables machine operation when released (position 1) or further depressed (position 3) by a panicked operator, the safety of operators using teach pendants or grip switches in hazardous environments is ensured.

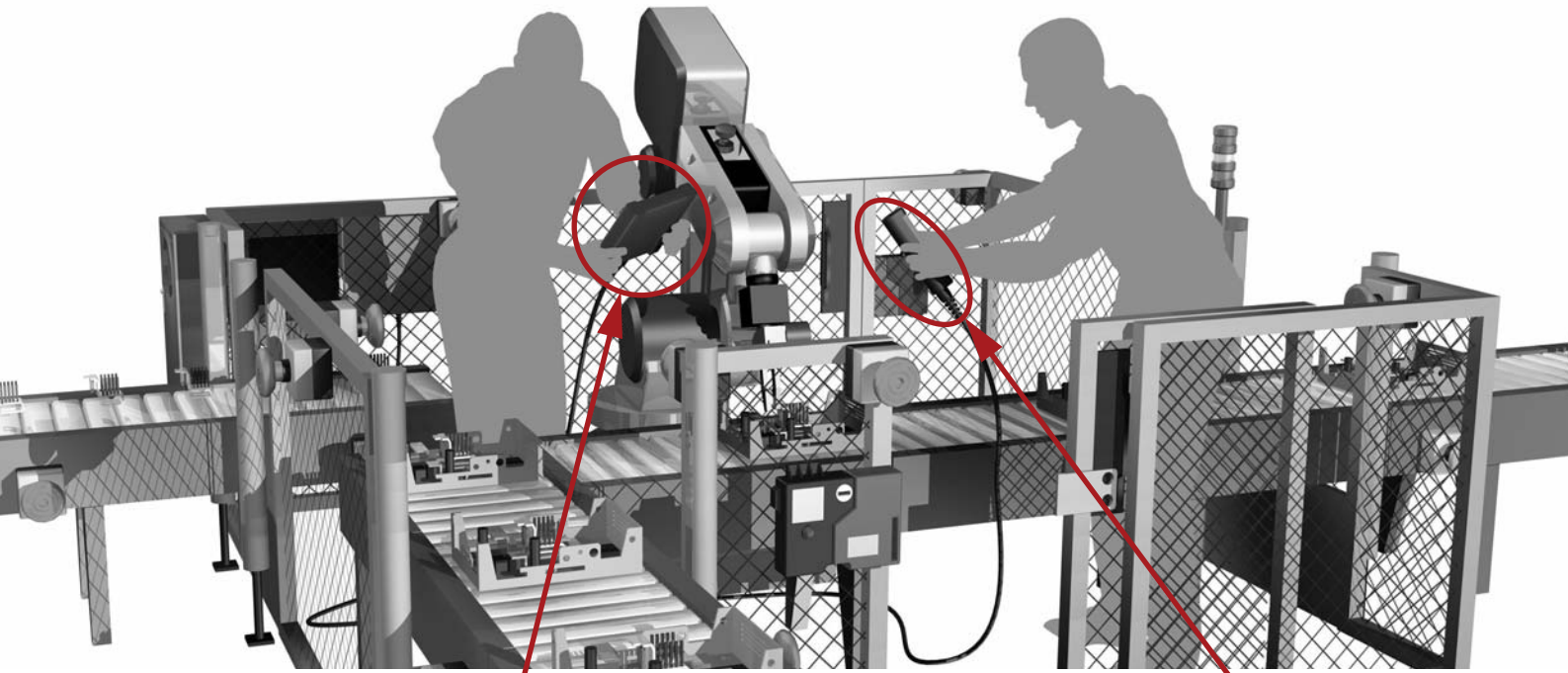

**HG2S CC Pendant**



**HE1G Grip Switch**



**HG1T Small Pendant**

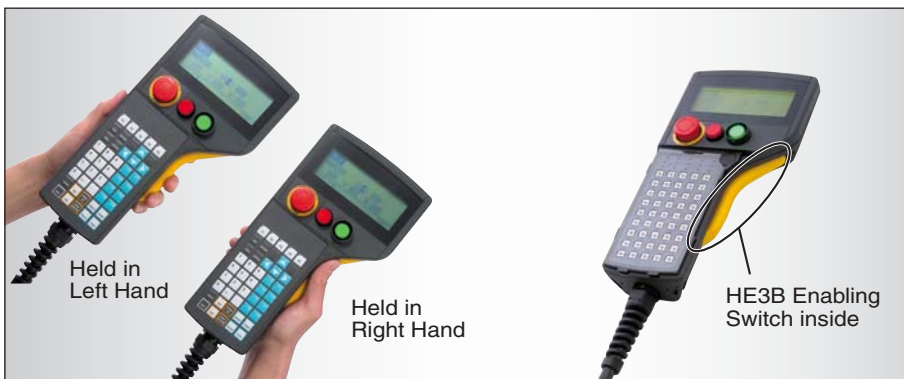

**HE9Z-GSH51 Grip Switch Housing + HE5B Enabling Switch**



## Operation of enabling switches

The requirement for operation of 3-position enabling switches (according to IEC 60204-1; 9.2.5.8):

When an enabling device is provided as a part of a system, it shall be designed to allow motion when actuated in one position only. In any other position motion shall be stopped.

– for a three-position type:

- position 1: off-function of the switch (actuator is not operated)
- position 2: enabling function (actuator is operated in its mid position)
- position 3: off-function (actuator is operated past its mid position)

When returning from position 3 to position 2, the function shall be ended.

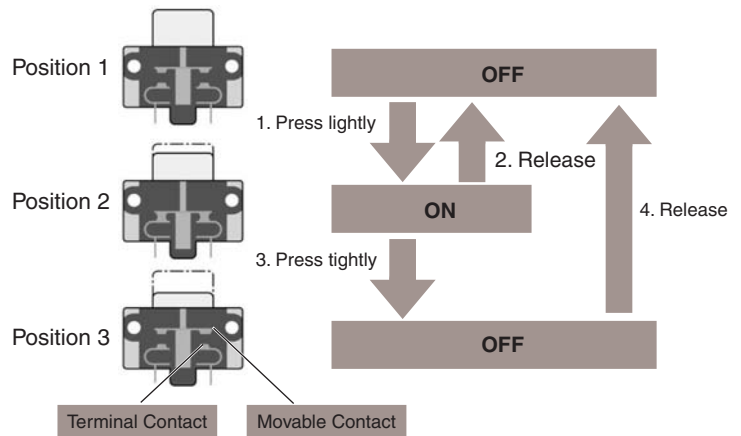

## Disparity detection of two contacts

- A high level of safety—safety category 3 or higher (ISO 13849-1)—is required when an operator works near a hazard inside a safety guard.

When released to position 1, the contacts are opened (turned off) by the force of a released spring. The 3-position enabling switches must be prepared for failures such as contact welding and short-circuits, and a dual circuit is provided. Even if one contact fails, the remaining contact can disable machine operation. Furthermore, a disparity detection circuit is provided so that machine operation is disabled when a disparity between the two circuits is detected using a safety relay module.

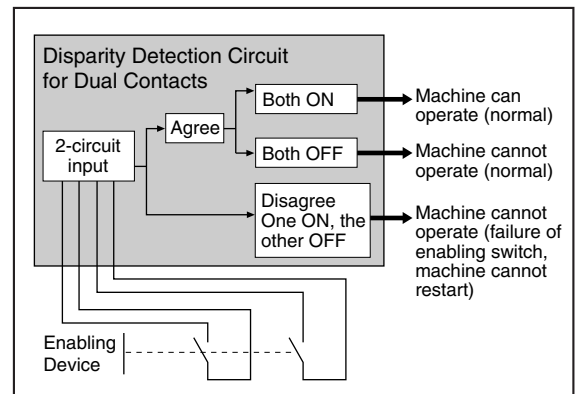

## International standards on enabling switches

### • IEC 60204-1: 1997

**9.2.4** Where it is necessary to suspend safeguarding, (e.g. for setting or maintenance purposes), a mode selection device or means capable of being secured (e.g. locked) in the desired mode shall be provided so as to prevent automatic operation. In addition, one or more of the following means shall be provided:

- a portable control station (e.g. pendant) with an emergency stop device and, where appropriate, an enabling device. Where a portable station is in use, motion may be initiated only from that station.

### • ISO 12100-2: 2003 Control mode for setting, teaching, process changeover, fault-finding, cleaning or maintenance

**4.11.9** Where, for setting, teaching, process changeover, fault-finding, cleaning or maintenance of machinery, a guard has to be displaced or removed and/or a protective device has to be disabled, and where it is necessary for the purpose of these operations for the machinery or part of the machinery to be put in operation, safety of the operator shall be achieved using a specific control mode which simultaneously:

- permits operation of the hazardous elements only by continuous actuation of an enabling device, a hold-to-run control device or a two-hand control device.

### • ANSI/RIA R15.06

The pendant or teaching control device shall have an enabling device using a three position switch which, when continuously held in a detented position, permits motion. Release of or compression past the midpoint detent of the device shall stop robot motion using circuitry consistent with 4.5.





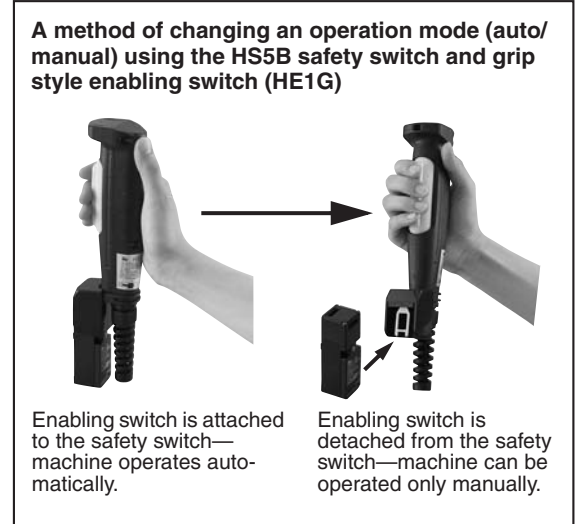
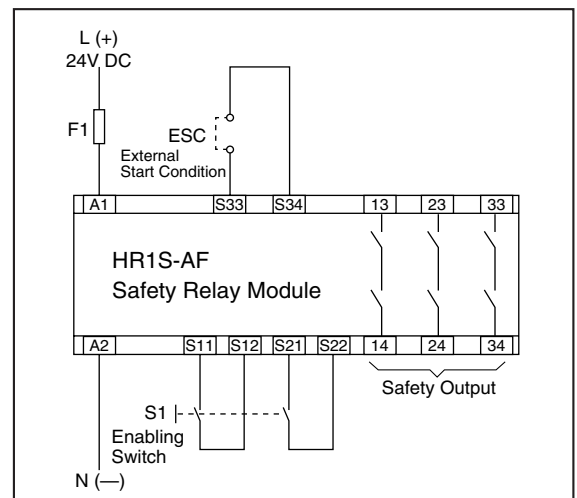

Note: Tests have shown that human reaction to an emergency may be to release an object, or hold on tighter, thus compressing an enabling device. Design and installation of the enabling device should consider the ergonomics issues of sustained activation.









### • ANSI B11.19, 12.3.1.3

Enabling devices shall be designed and constructed to permit limited and supervised machine motion while personnel are inside a hazard area.



## Types

Type and Appearance	Enabling Switch				
	Side Mounting Type (1-contact) Top Mounting Type (1-contact)	Rectangular Type (6 contacts maximum) (without rubber boot)	Rectangular Type (6 contacts maximum) (with rubber boot)	16mm Round Hole Type (without rubber boot)	16mm Round Hole Type (with rubber boot)
	HE1B	HE2B		HE3B	
<p>Small and ideal for installing in enabling devices.</p> 	<p>Ideal for 4-finger operation. A maximum of 6 contacts can be installed (2 contacts each for 3-position switch, button return monitor and button depress monitor)</p>  <p>Monitor Switch</p>	 <p>Monitor Switch</p>	<p>Rectangular shape Can be mounted easily in a <math>\phi 16</math> mm round hole.</p> 		
Degree of Protection	IP40		IP65	IP40	IP65
Applicable Standards	IEC / EN 60947-5-1 (DEMKO approval) UL508 (UL recognized) CSA C22. No. 14 (c-UL recognized) JIS C8201-5-1				
Standards					
Page	6, 7		8 to 10		11, 12

Type and Appearance	Enabling Switch		Grip Switch		
	2-contact, $\phi 16$ mm Round Hole, With Rubber Boot		With Monitor Switch	With Emergency Stop Switch	With Momentary Pushbutton Switch
	HE5B	HE9Z-GSH51 (Note)	HE1G		
<p>Can be mounted easily on <math>\phi 16</math> mm round hole.</p> 	<p>Compact grip switch housing</p> 	<p>2-contact 3-position switch and monitoring contact.</p> 	<p>Combination of emergency stop switch and 3-position enabling switch.</p> 	<p>Combination of 3-position enabling switch and momentary pushbutton switch (1NO/2NO).</p> 	
Degree of Protection	IP65		IP66	IP65	
Applicable Standards	IEC / EN 60947-5-1 (DEMKO approval) UL508 (UL recognized) CSA C22. No. 14 (c-UL recognized) JIS C8201-5-1	IEC / EN60529 UL50	IEC / EN 60947-5-1 (BG approval) GS-ET-22 (BG approval) UL508 (UL listed) CSA C22. No. 14 (c-UL listed) JIS C8201-5-1		
Standards					
Page	13, 14		15	16 to 18	

Note: HE9Z-GSH51 is housing only. Install the HE5B enabling switch to use as a grip switch. See page 15 for details.

# Selection Chart of Enabling Switch and Grip Switch

ISO 12100-2: 2003  
Control mode for setting, teaching, process changeover, fault-finding, cleaning or maintenance  
4.11.9 permits operation of the hazardous elements only by continuous actuation of an enabling device, a hold-to-run control device or a two-hand control device;

IEC 60204-1: 1997  
9.2.5.8 When an enabling device is provided as a part of a system, it shall be designed to allow motion when actuated in one position only. In any other position motion shall be stopped.

ANSI/ RIA R15.06  
4.7.3 Enabling device The pendant or teaching control device shall have an enabling device using a three position switch, which continuously held in a detented position, permits motion.

ANSI B11.19  
12.3.1.1 Enabling devices shall be designed and constructed to permit limited and supervised machine motion while personnel are inside a hazard area.

SEMI S2-0703  
20.4 Industrial robots and industrial robot systems should meet the requirements of appropriate national or international standards, e.g., ANSI/RIA R15.06, ISO standards 10218, EN 775.

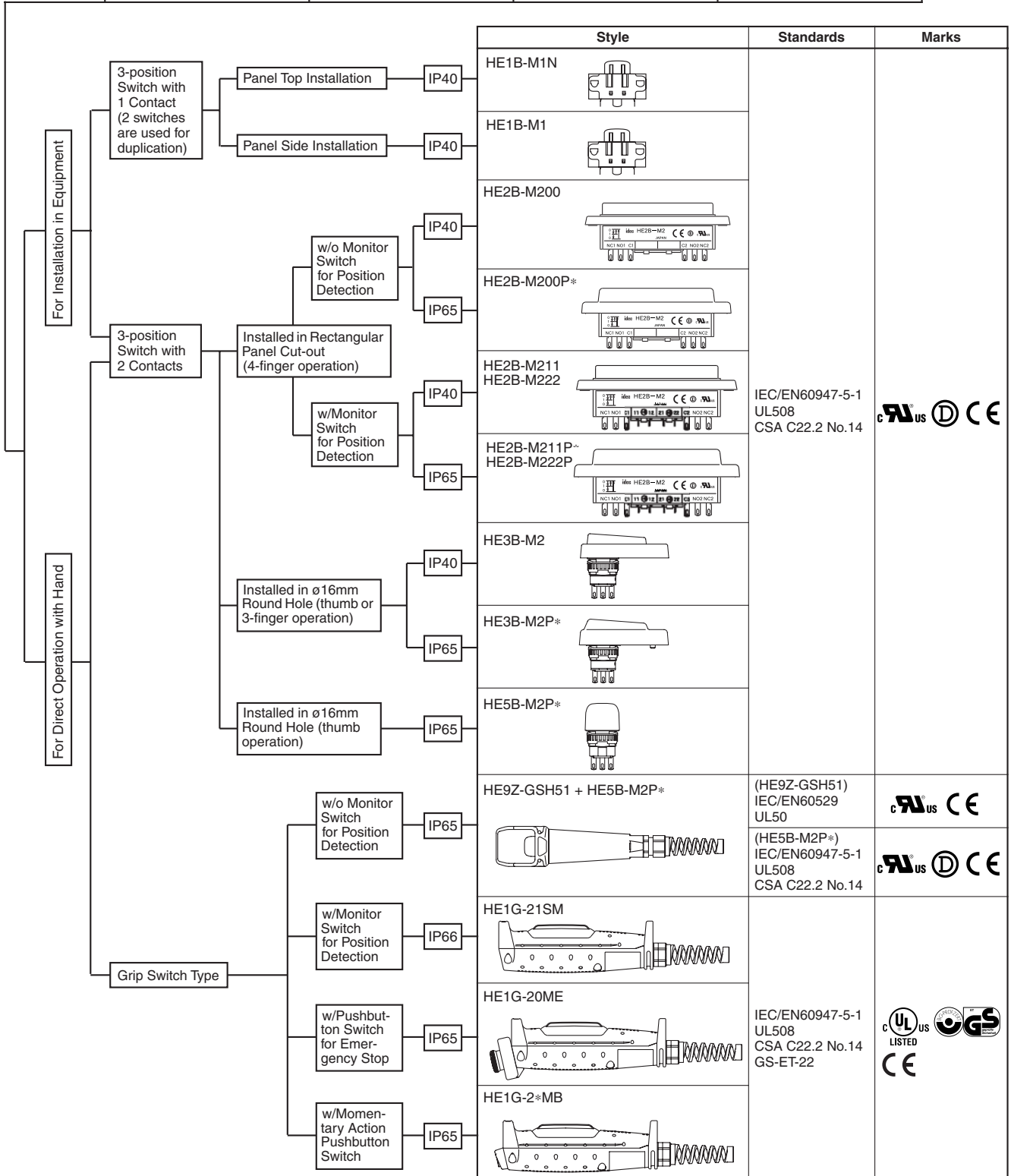

# HE1B Enabling Switch

**3-position enabling switch to avoid hazards.  
Ideal for installing in teach pendants and other enabling devices.**

- Ergonomically-designed OFF-ON-OFF.
- Direct opening action mechanism for shifting from position 2 (ON) to position 3 (OFF) (EN 60947-5-1/IEC 60947-5-1, Annex K).
- The switch does not turn ON while being released from position 3 (OFF when pressed) to position 1 (OFF when released) (IEC60204-1, 9.2.5.8).
- Reliable performance in compact and lightweight package.

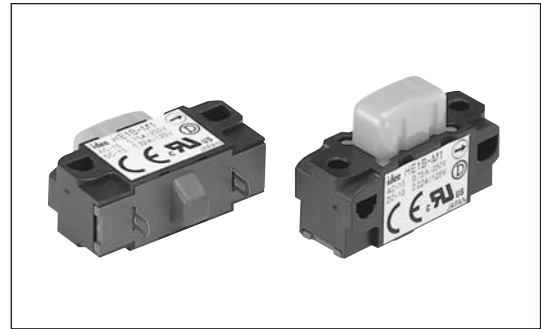

## Types

Mounting Style	Contact Configuration	Type No.	Ordering Type No.	Package Quantity
Side Mounting	1 contact (3-position)	HE1B-M1	HE1B-M1PN10	10
Top Mounting		HE1B-M1N	HE1B-M1NPN10	

- Minimum applicable load (reference value): 3V AC/DC, 5 mA

## Ratings

### • Contact Ratings

Rated Insulation Voltage (Ui)		250V			
Rated Thermal Current (Ith)		5A			
Rated Voltage (Ue)		30V	125V	250V	
Rated Current (Ie)	AC 50/60 Hz	Resistive Load (AC-12)	—	3A	1.5A
		Inductive Load (AC-15)	—	1.5A	0.75A
	DC	Resistive Load (DC-12)	2A	0.4A	0.2A
		Inductive Load (DC-13)	1A	0.22A	0.1A
Contact Configuration (3-position switch)		1 contact			

- Minimum applicable load (reference value): 3V AC/DC, 5 mA

## Specifications

Applicable Standards	IEC 60947-5-1, EN 60947-5-1 (DEMKO approval) UL508 (UL recognized), CSA C22.2, No. 14 (c-UL recognized), JIS C8201-5-1
Applicable Standards for Use	ISO 12100 / EN 292, IEC 60204-1 / EN 60204-1 ISO 11161 / prEN 11161, ISO 10218 / EN 775, ANSI/RIA R15.06, ANSI B11.19
Operating Temperature	-25 to +60°C (no freezing)
Relative Humidity	45 to 85% (no condensation)
Storage Temperature	-40 to +80°C (no freezing)
Pollution Degree	2
Contact Resistance	50 mΩ maximum (initial value)
Insulation Resistance	100 MΩ minimum
Impulse Withstand Voltage	2.5 kV
Operating Frequency	1,200 operations per hour
Mechanical Durability	Position 1 → 2 → 1: 1,000,000 operations Position 1 → 2 → 3 → 1: 100,000 operations
Electrical Durability	100,000 operations minimum
Shock Resistance	Operating extremes: 150 m/s <sup>2</sup> Damage limits: 1,000 m/s <sup>2</sup>
Vibration Resistance	Operating extremes: 5 to 55 Hz, amplitude 0.5 mm Damage limits: 16.7 Hz, amplitude 1.5 mm
Terminal Style	Solder terminal
Applicable Wire	1 cable, 0.5 mm <sup>2</sup> maximum
Solder Terminal Heat Resistance	310 to 350°C, 3 seconds maximum
Terminal Tensile Strength	20N minimum
Mounting Screw Recommended Tightening Torque	HE1B-M1: M3 screw / 0.5 to 0.8 N·m HE1B-M1N: M2.6 screw / 0.4 to 0.6 N·m
Degree of Protection	IP40, except terminals
Conditional Short-circuit Current	50A (250V) (Use 250V/10A fast acting type fuse for short-circuit protection.)
Direct Opening Force	30N minimum (position 2 → 3)
Operator Strength	250N minimum
Weight (approx.)	6g

# HE1B Enabling Switch

## Operation Characteristics

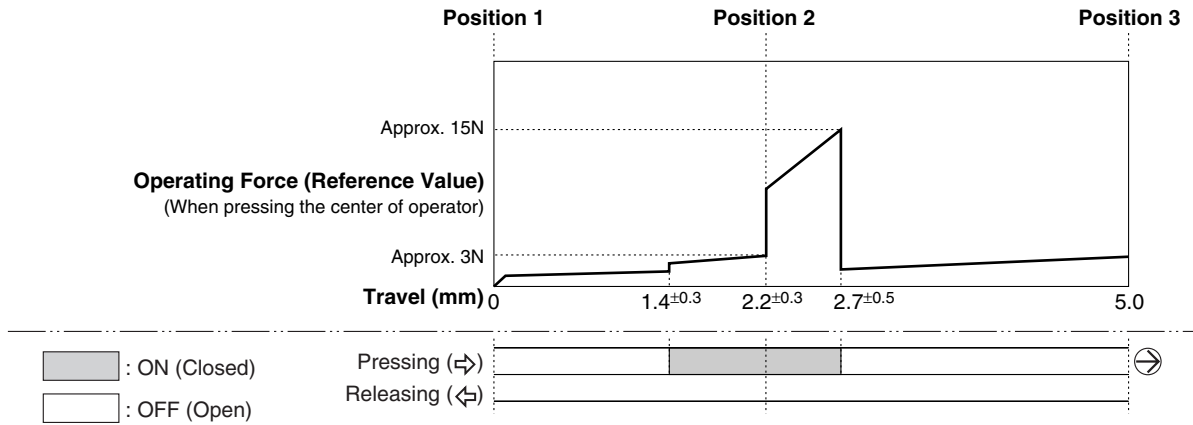

## Dimensions

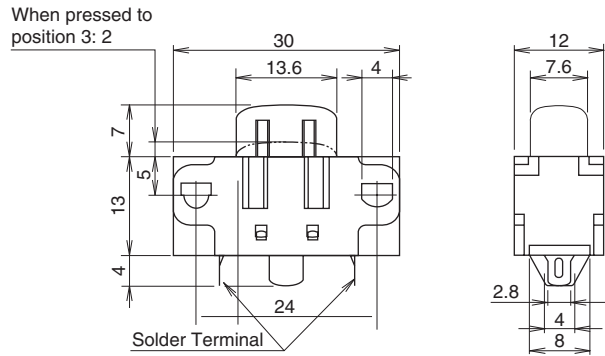

## Mounting Hole Layout

- HE1B-M1 (side mounting type)  
Mounting screw: M3

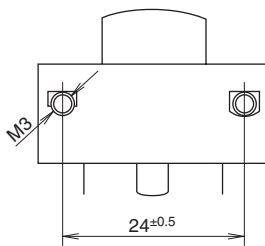

- HE1B-M1N (top mounting type)  
Mounting screw: M2.6

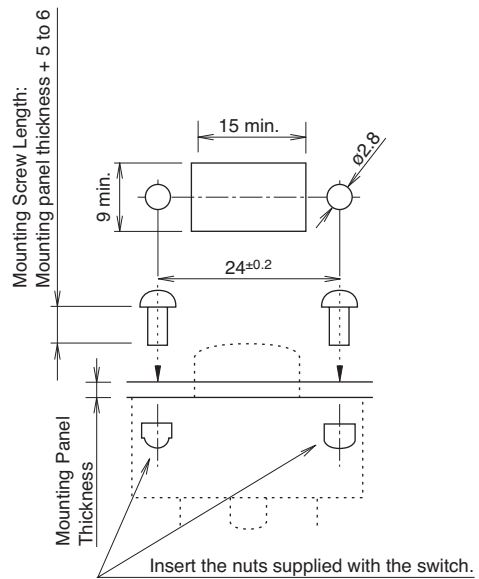

Note: When installed on a mounting panel thicker than 2 mm, the actuator surface is below the panel when the button is pressed to position 3.

All dimensions in mm.

# HE2B Enabling Switch

## Multi-contact 3-position enabling switches Ideal for installing in large teach pendants

- Ergonomically-designed OFF-ON-OFF operation.
- Easy recognition of position 1 to 2 transition is made possible by a snap action switch.
- Sufficient difference in operating force is provided for shifting from position 2 to 3.
- Low pressure is required to maintain position 2, allowing for longtime operation.
- Reliable operation is assured even when the edge of the operator button is pressed.
- The switch does not turn ON while being released from position 3 (OFF) to position 1 (OFF) (IEC60204-1, 9.2.5.8).
- Some teach pendants are equipped with two 3-position enabling switches, and when one switch is pressed to position 3 (OFF), the other switch must not enable machine operation even when pressed to position 2. Enabling of machine operation must resume after both switches are released. For this purpose, also available are 3-position enabling switches with monitoring switches for button returned to position 1 and button pressed to position 3 (monitor switches have direct opening action mechanism).
- Two contacts are provided in a 3-position enabling switch so that even if one contact fails due to welding or short-circuit, the other contact can disable machine operation.
- The waterproof rubber boot provides IP65 protection.

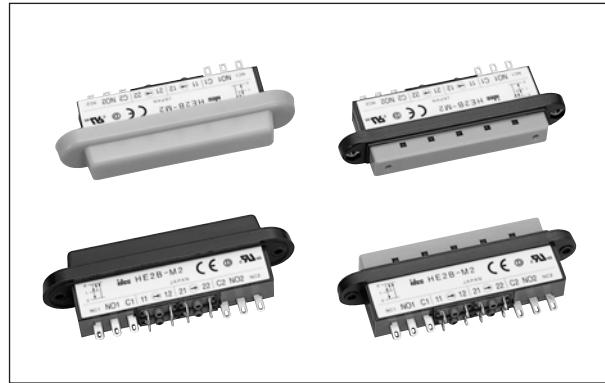

### Types

Type	Contact Configuration			Type No.	Ordering Type No.	Package Quantity	
	3-position Switch	Button Return Monitor Switch	Button Depress Monitor Switch				
Without Rubber Boot	2	0	0	HE2B-M200	HE2B-M200 HE2B-M200PN10	1 10	
	2	1	1	HE2B-M211	HE2B-M211 HE2B-M211PN10	1 10	
	2	2	2	HE2B-M222	HE2B-M222 HE2B-M222PN10	1 10	
With Rubber Boot	Rubber Boot Material: Silicon Rubber Color: Y: yellow B: black	2	0	0	HE2B-M200P*	HE2B-M200P* HE2B-M200P*PN10	1 10
		2	1	1	HE2B-M211P*	HE2B-M211P* HE2B-M211P*PN10	1 10
		2	2	2	HE2B-M222P*	HE2B-M222P* HE2B-M222P*PN10	1 10
	Rubber Boot Material: NBR/PVC Polyblend Color: gray	2	0	0	HE2B-M200PN1	HE2B-M200PN1 HE2B-M200PN1PN10	1 10
		2	1	1	HE2B-M211PN1	HE2B-M211PN1 HE2B-M211PN1PN10	1 10
		2	2	2	HE2B-M222PN1	HE2B-M222PN1 HE2B-M222PN1PN10	1 10

Note: Specify rubber boot color code in place of \* in the Type No.

### • Type No. Development

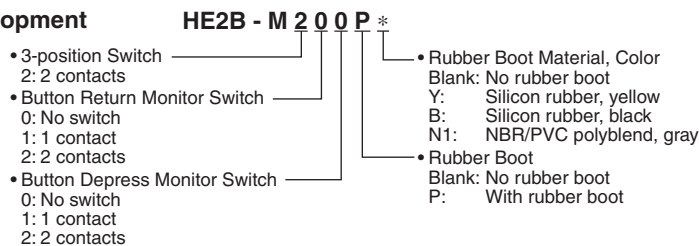

### Ratings

#### • Contact Ratings

Rated Insulation Voltage (Ui)		250V				
Rated Thermal Current (Ith)		3A				
Rated Voltage (Ue)		30V	125V	250V		
Rated Current (Ie)	3-position Switch	AC	Resistive Load (AC-12)	—	1A	0.5A
			Inductive Load (AC-15)	—	0.7A	0.5A
		DC	Resistive Load (DC-12)	1A	0.2A	—
	Button Return Monitor Switch Button Depress Monitor Switch	AC	Resistive Load (AC-12)	—	2A	1A
			Inductive Load (AC-15)	—	1A	0.5A
		DC	Resistive Load (DC-12)	2A	0.4A	0.2A
Contact Configuration	3-position Switch	2 contacts				
	Button Return Monitor Switch	0 to 2 contacts				
	Button Depress Monitor Switch	0 to 2 contacts				

• Minimum applicable load (reference value): 3V AC/DC, 5 mA

# HE2B Enabling Switch

## Specifications

Applicable Standards	IEC 60947-5-1, EN60947-5-1 (DEMKO approval), UL508 (UL recognized) CSA C22.2, No. 14 (c-UL recognized), JIS C8201-5-1
Applicable Standards for Use	ISO 12100 / EN 292, IEC 60204-1 / EN 60204-1 ISO11161 / prEN 11161, ISO10218 / EN 775, ANSI / RIA R15.06, ANSI B11.19
Operating Temperature	-25 to +60°C (no freezing) (without rubber boot, with silicon rubber boot) -10 to +60°C (no freezing) (with NBR/PVC polyblend rubber boot)
Relative Humidity	45 to 85% RH (no condensation)
Storage Temperature	-40 to +80°C (no freezing)
Pollution Degree	2 (inside panel, terminal side) 3 (outside panel, operator side)
Contact Resistance	50 mΩ maximum (initial value)
Insulation Resistance	Between live and dead metal parts: 100 MΩ minimum (500V DC megger) Between terminals of different poles: 100 MΩ minimum (500V DC megger)
Impulse Withstand Voltage	2.5 kV
Operating Frequency	1,200 operations per hour
Mechanical Durability	Position 1 → 2 → 1: 1,000,000 operations minimum Position 1 → 2 → 3 → 1: 100,000 operations minimum
Electrical Durability	100,000 operations minimum
Shock Resistance	Operating extremes: 150 m/s <sup>2</sup> Damage limits: 1,000 m/s <sup>2</sup>
Vibration Resistance	Operating extremes: 5 to 55 Hz, amplitude 0.5 mm Damage limits: 16.7 Hz, amplitude 1.5 mm
Terminal Style	Solder terminal
Applicable Wire	1 cable, 0.5 mm <sup>2</sup> maximum
Solder Terminal Heat Resistance	310 to 350 °C, 3 seconds maximum
Terminal Tensile Strength	20N minimum
Mounting Screw Recommended Tightening Torque	0.5 to 0.8 N·m
Degree of Protection	IP40 (without rubber boot) IP65 (with rubber boot)
Conditional Short-circuit Current	50A (250V) (Use 250V/10A fast acting type fuse for short-circuit protection.)
Direct Opening Force	60N minimum (button return monitor and button depress monitor switches)
Operator Strength	500N minimum (when pressing the entire button surface)
Weight (approx.)	26g (without rubber boot) 30g (with rubber boot)

## Operation Characteristics

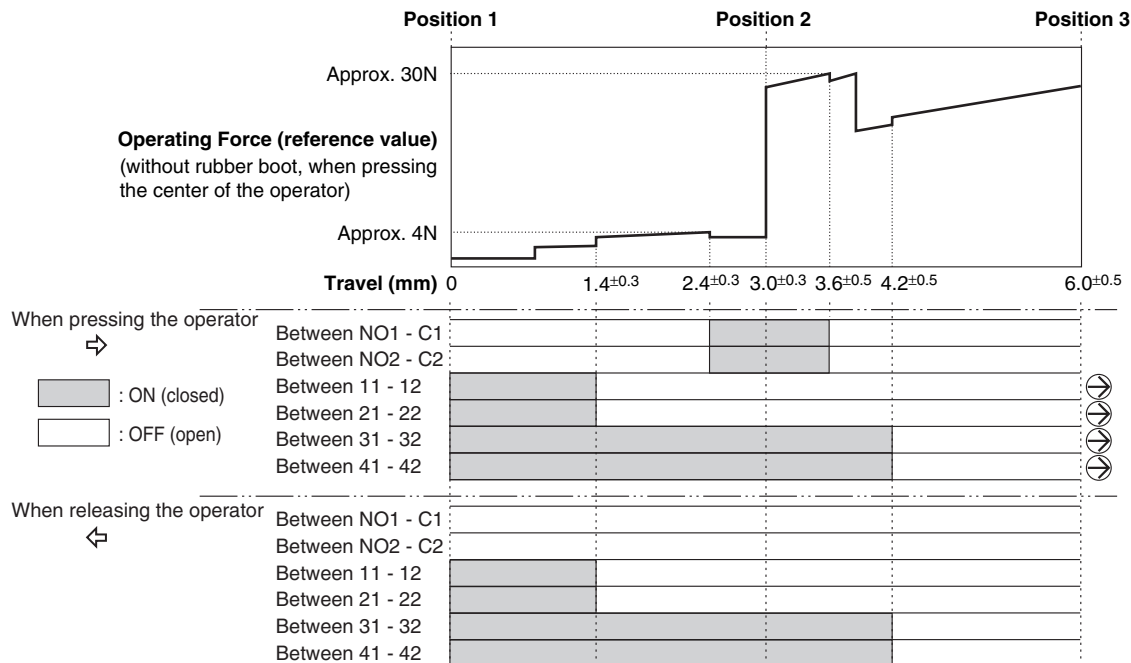

**Notes:**

- When a rubber boot is used, the operating force depends on the operating temperature.
- The operating force to shift the switch from position 2 to position 3 can be changed. For details, contact IDEC.

# HE2B Enabling Switch

## Terminal Arrangement (Bottom View)

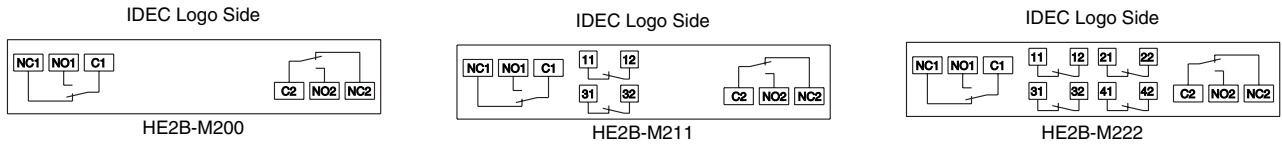

- 3-position switch (note): 2 contacts, terminal nos. between NO1 – C1, NO2 – C2
  - Button return monitor switch: 0 to 2 contacts, terminal nos. between 11 – 12, 21 – 22
  - Button depress monitor switch: 0 to 2 contacts, terminal nos. between 31 – 32, 41 – 42
- Note: Use NO and C terminals for OFF → ON → OFF 3-position switch (NC terminal is not used).

## Dimensions

### • Without Rubber Boot

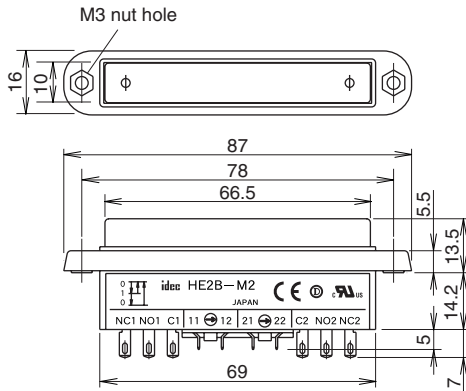

### • With Rubber Boot

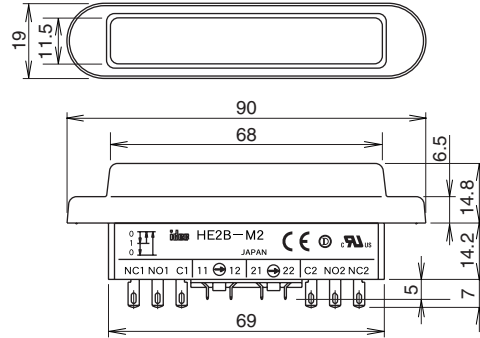

- M3 nuts are supplied with the HE2B enabling switch.

## Mounting Hole Layout

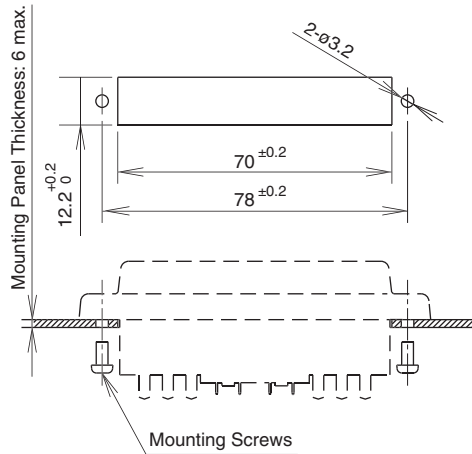

- Mounting screw: Two M3 screws
- Length of mounting screw: The thickness of mounting panel + 4 to 5 mm

All dimensions in mm.

## Accessories

### • Replacement Rubber Boot

Material	Color	Type No.	Ordering Type No.	Package Quantity
Silicon Rubber	Y: yellow	HE9Z-D2*	HE9Z-D2*PN10	10
	B: black			
NBR/PVC Polyblend	Gray	HE9Z-D2N1	HE9Z-D2N1PN10	

Note: Specify a rubber boot color code in place of \* in the Type No.



# HE3B Enabling Switch

**Rectangular operator part with  $\phi 16$  mm mounting for easy installation.  
2-contact 3-position enabling switches ideal for installing in small teach pendants.**

- Ergonomically-designed OFF-ON-OFF operation.
- Easy recognition of position 1 to 2 transition is made possible by a snap action switch.
- Sufficient difference in operating force is provided for shifting from position 2 to position 3.
- Low pressure is required to maintain in position 2 allowing for longtime operation.
- Reliable operation is assured even when the edge of the operator button is pressed.
- The switch does not turn ON while being released from position 3 (OFF) to position 1 (OFF) (IEC60204-1, 9.2.5.8).
- Two contacts are provided in a 3-position enabling switch so that even one contact fails due to welding or short-circuit, the other contact can disable machine operation.
- The waterproof rubber boot provides IP65 protection.



## Types

Type	Contact Configuration	Type No.	Ordering Type No.	Package Quantity	
Without Rubber Boot	2 contacts (3-position switch)	HE3B-M2	HE3B-M2	1	
			HE3B-M2PN10	10	
With Rubber Boot		Rubber Boot Material: Silicon Rubber Color: Y: yellow, B: black	HE3B-M2P*	HE3B-M2P*	1
				HE3B-M2P*PN10	10
		Rubber Boot Material: NBR/PVC Polyblend Color: gray	HE3B-M2PN1	HE3B-M2PN1	1
				HE3B-M2PN1PN10	10

Note: Specify rubber boot color code in place of \* in the Type No.

## Contact Ratings

Rated Insulation Voltage (Ui)			125V	
Rated Thermal Current (Ith)			3A	
Rated Voltage (Ue)			30V	125V
Rated Current (Ie)	AC	Resistive Load (AC-12)	—	1A
		Inductive Load (AC-15)	—	0.7A
	DC	Resistive Load (DC-12)	1A	0.2A
		Inductive Load (DC-13)	0.7A	0.1A
Contact Configuration (3-position switch)			2 contacts	

Minimum applicable load (reference value): 3V AC/DC, 5 mA

## Specifications

Applicable Standards	IEC 60947-5-1, EN 60947-5-1 (DEMKO approval) UL508 (UL recognized), CSA C22.2, No. 14 (c-UL recognized), JIS C8201-5-1
Applicable Standards for Use	ISO 12100 / EN 292, IEC 60204-1 / EN 60204-1 ISO 11161 / prEN 11161, ISO 10218 / EN 775 ANSI/RIA R15.06, ANSI B11.19
Operating Temperature	-25 to +60°C (no freezing) (without rubber boot, with silicon rubber boot) -10 to +60°C (no freezing) (with NBR/PVC polyblend rubber boot)
Relative Humidity	45 to 85% (no condensation)
Storage Temperature	-40 to +80°C (no freezing)
Pollution Degree	2 (inside panel, terminal side) 3 (outside panel, operator side)
Contact Resistance	50 m $\Omega$ maximum (initial value)
Insulation Resistance	Between live and dead metal parts: 100 M $\Omega$ minimum (500V DC megger) Between terminals of different poles: 100 M $\Omega$ minimum (500V DC megger)
Impulse Withstand Voltage	1.5 kV
Operating Frequency	1,200 operations per hour
Mechanical Durability	Position 1 $\rightarrow$ 2 $\rightarrow$ 1: 1,000,000 operations minimum Position 1 $\rightarrow$ 2 $\rightarrow$ 3 $\rightarrow$ 1: 100,000 operations minimum
Electrical Durability	100,000 operations minimum
Shock Resistance	Operating extremes: 150 m/s <sup>2</sup> Damage limits: 500 m/s <sup>2</sup>
Vibration Resistance	Operating extremes: 5 to 55 Hz, amplitude 0.5 mm Damage limits: 16.7 Hz, amplitude 1.5 mm
Terminal Style	Solder terminal
Applicable Wire	1 cable, 0.5 mm <sup>2</sup> maximum
Solder Terminal Heat Resistance	310 to 350°C, 3 seconds maximum
Terminal Tensile Strength	20N minimum
Locking Ring Recommended Tightening Torque	0.68 to 0.88 N·m
Degree of Protection	IP40 (without rubber boot) IP65 (with rubber boot)
Conditional Short-circuit Current	50A (250V) (Use 250V/10A fast acting type fuse for short-circuit protection.)
Operator Strength	500N minimum (pressing the entire operator surface)
Weight (approx.)	14g (without rubber boot) 18g (with rubber boot)

# HE3B Enabling Switch

## Operation Characteristics

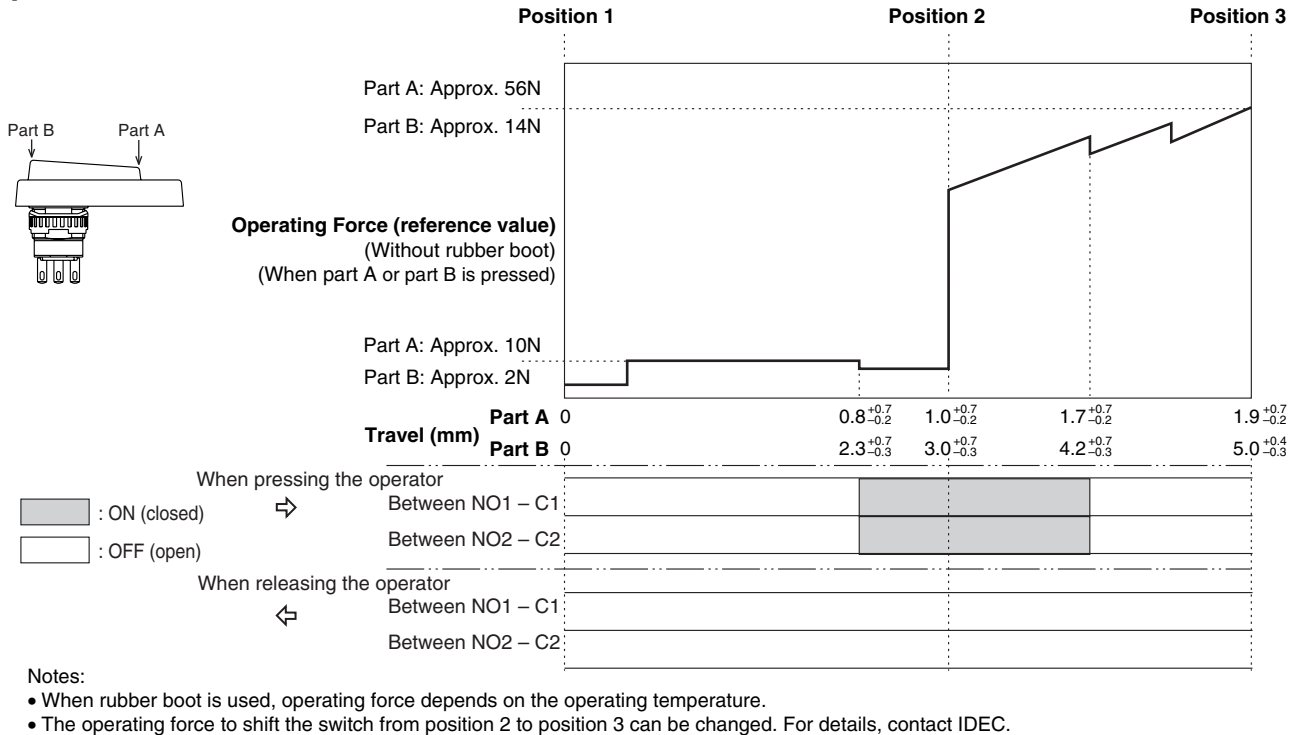

## Terminal Arrangement (Bottom View)

- 3-position switch (Note)
  - 2 contacts
- Terminal No.: between NO1 and C1, between NO2 and C2
- Note: Use NO and C terminals for the 3-position switch of OFF → ON → OFF operation (NC terminal is not used).

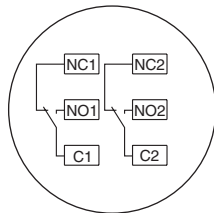

## Mounting Hole Layout

- Recommended tightening torque for locking ring: 0.68 to 0.88 N·m
- Use the locking ring wrench MT-001 for tightening.

Note: To maintain waterproof property of the switch, do not drill through the anti-rotation hole in the mounting panel. When not providing a hole, cut off the anti-rotation projection from the rubber boot. When cutting off the projection, ensure not to make a hole in the rubber boot.

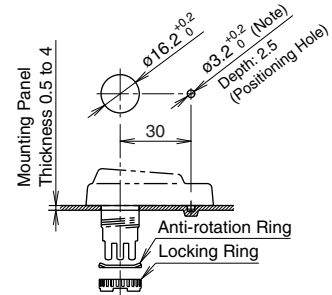

## Dimensions

### Without Rubber Boot

Mounting Panel Thickness: 0.5 to 4

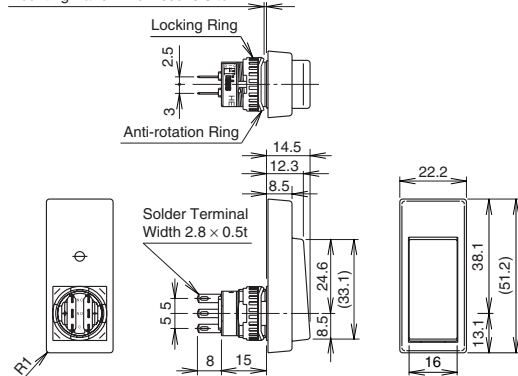

### With Rubber Boot

Mounting Panel Thickness: 0.5 to 4

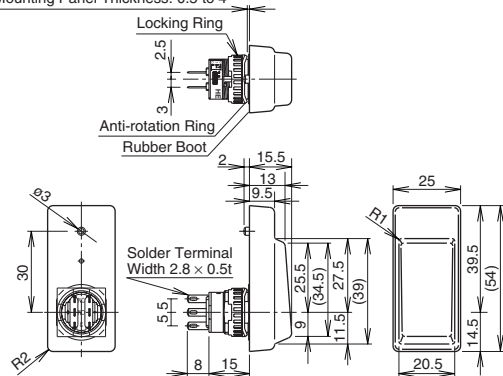

All dimensions in mm.

## Accessories

### Replacement Rubber Boot

Material	Color	Type No.	Ordering Type No.	Package Quantity
Silicon Rubber	Y: yellow B: black	HE9Z-D3*	HE9Z-D3*PN10	10
NBR/PVC Polyblend	Gray	HE9Z-D3N1	HE9Z-D3N1PN10	

• Specify rubber boot color code in place of \* in the Type No.

### Locking Ring Wrench

Type No: MT-001  
Material: Metal



# HE5B Enabling Switch

Round-shaped operator for  $\phi 16$  mm mounting hole.

3-position enabling switch with two contacts, ideal for installing in small teaching pendants.

- Ergonomically-designed OFF-ON-OFF operation.
- Easy recognition of position 1 to 2 transition is made possible by a snap action switch.
- Sufficient difference in operating force is provided for shifting from position 2 to position 3.
- Low pressure is required to maintain position 2, allowing longtime operation.
- Grip switch housing available.
- The switch does not turn ON when being released from position 3 (OFF when pressed) to position 1 (OFF when released) (IEC60204-1, 9.2.5.8).
- Two contacts are provided in a 3-position enabling switch so that even if one contact fails due to welding or short-circuit, the other contact can disable machine operation.
- The waterproof rubber boot provides IP65 protection.



## Types

Type	Contact Configuration	Type No.	Ordering Type No.	Package Quantity	
With Rubber Boot	Silicon Rubber Y: yellow B: black	2 contacts (3-position switch)	HE5B-M2P*	HE5B-M2P*	1
			HE5B-M2P*PN10	10	
	NBR/PVC		HE5B-M2PN1	HE5B-M2PN1	1
			HE5B-M2PN1PN10	10	

- Specify rubber boot color code in place of \* in the Type No.

## Contact Ratings

Rated Insulation Voltage (Ui)		125V		
Rated Current (Ith)		3A		
Rated Voltage (Ue)		30V	125V	
Rated Current (Ie)	AC	Resistive Load (AC-12)	–	0.5A
		Inductive Load (AC-15)	–	0.3A
	DC	Resistive Load (DC-12)	1A	–
		Inductive Load (DC-13)	0.7A	–
Contact Configuration (3-position switch)		2 contacts		

Minimum applicable load (reference): 3V AC/DC, 5mA

Applicable operation area depends on the operating conditions and load.

## Specifications

Applicable Standards	IEC 60947-5-1, EN 60947-5-1 (DEMKO approval), UL508 (UL recognized), CSA C22.2, No. 14 (c-UL recognized), JIS C8201-5-1
Applicable Standards for Use	ISO 12100 / EN292, IEC 60204-1 / EN 60204-1, ISO 11161 / prEN 11161, ISO 10218 / EN 775, ANSI/RIA R15.06, ANSI B11.19
Operating Temperature	Silicon rubber boot: –25 to 60°C (no freezing) NBR/PVC Polyblend rubber boot: –10 to 60°C (no freezing)
Relative Humidity	45 to 85% (no condensation)
Storage Temperature	–40 to +80°C (no freezing)
Pollution Degree	2 (inside panel, terminal side) 3 (outside panel, operator side)
Contact Resistance	50 mΩ maximum (initial value)
Insulation Resistance	Between live and dead metal parts: 100 MΩ minimum (500V DC megger) Between terminals of different pole: 100 MΩ minimum (500V DC megger)
Impulse Withstand Voltage	1.5 kV
Operating Frequency	1,200 operations per hour
Mechanical Durability	Position 1 → 2 → 1: 1,000,000 operations minimum Position 1 → 2 → 3 → 1: 100,000 operations minimum
Electrical Durability	100,000 operations minimum
Shock Resistance	Operating extremes: 150 m/s <sup>2</sup> Damage limits: 500 m/s <sup>2</sup>
Vibration Resistance	Operating extremes: 5 to 55 Hz, amplitude 0.5 mm Damage limits: 5 to 55 Hz, amplitude 0.5 mm
Terminal Style	Solder terminal
Applicable Wire	0.5 mm <sup>2</sup> maximum per line
Solder Terminal Heat Resistance	310 to 350°C, 3 seconds maximum
Terminal Tensile Strength	20 N minimum
Locking Ring Recommended Tightening Torque	0.29 to 0.49 N·m
Degree of Protection	IP65
Conditional Short-circuit Current	50A (125V) (Use 250V/10A fast acting type fuse for short circuit protection.)
Operator Strength	250N minimum (when pressing the entire operator surface)
Weight (approx.)	9g

# HE5B Enabling Switch

## Operating Characteristics

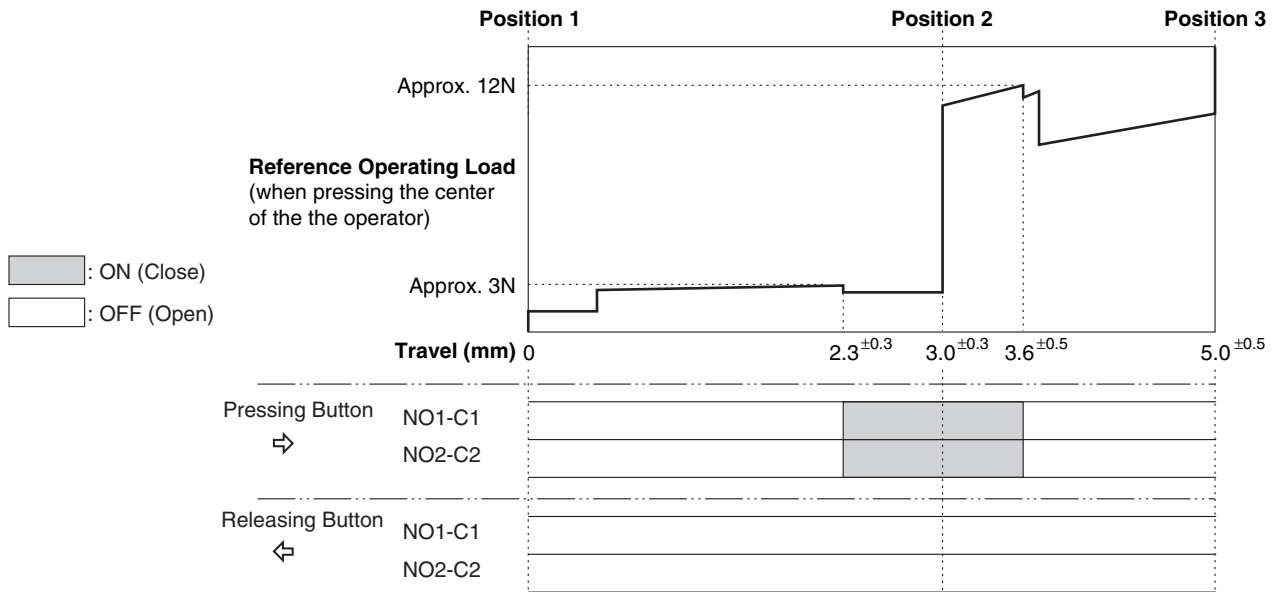

**Notes:**

- Operating force depends on ambient temperature.
- The operating force to shift the switch from position 2 to position 3 can be changed. For details, consult IDEC.

## Terminal Arrangement (Bottom View)

- 3-position switch (Note)
- 2 contacts

Terminal No.: between NO1 and C1, NO2 and C2

Note: For OFF → ON → OFF 3-position switches, use NO and C terminals (NC terminal is not used).

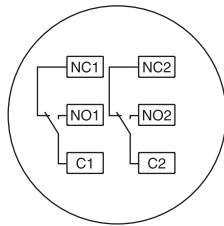

## Mounting Hole Layout

- Recommended Tightening Torque for Locking Ring: 0.29 to 0.49 N·m
- Use the MT-001 locking ring wrench for tightening.

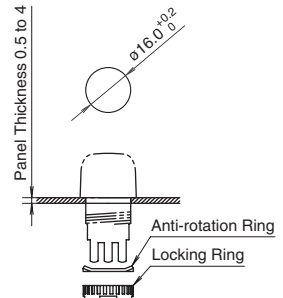

## Dimensions

### With Rubber Boot

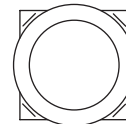
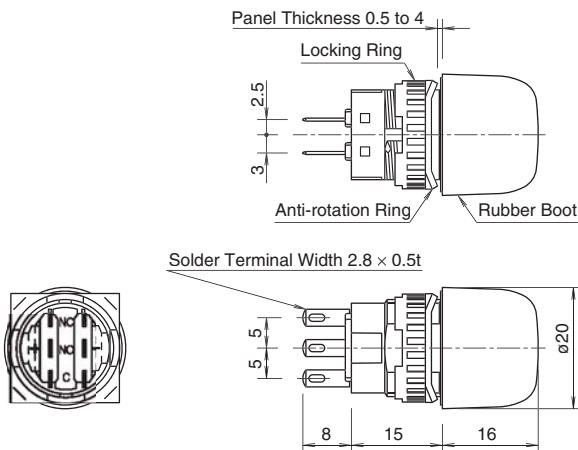

All dimensions in mm.

## Accessories

### • Replacement Rubber Boot

Rubber Boot Material	Color	Type No.	Ordering Type No.	Package Quantity
Silicon Rubber	B: black Y: yellow	HE9Z-D5*	HE9Z-D5*PN10	10
NBR/PVC Polyblend	Gray	HE9Z-D5N1	HE9Z-D5N1PN10	

• Specify rubber boot color code in place of \* in the Type No.



### • Locking Ring Wrench

Type No: MT-001  
Material: Metal



# HE5B Enabling Switch

## • Grip Switch Housing

HE5B enabling switches can be installed in the HE9Z-GSH51 grip switch housing to be used as 3-position grip switches.

## Types

Type No.	Ordering Type No.	Package Quantity
HE9Z-GSH51	HE9Z-GSH51	1

## Specifications

Applicable Standards	IEC / EN 60529 UL50
Operating Temperature	-25 to 60°C (no freezing)
Relative Humidity	45 to 85% RH (no condensation)
Storage Temperature	-40 to 80°C (no freezing)
Pollution Degree	3
Shock Resistance	Damage limits: 500 m/s <sup>2</sup>
Vibration Resistance	Damage limits: 5 to 55 Hz, amplitude 0.5 mm
Electric Shock Protection Class	Class II (when using HE5B-M2P*)
Applicable Cable	Outside diameter ø4.5 to 10 mm
Conduit Size	M16 (connector is supplied with the grip switch housing)
Degree of Protection	IP65 (with HE5B-M2P*) NEMA type 4X indoor use only (with HE5B-M2P*)
Weight (approx.)	65g (grip switch housing only)

- The above specifications are for the grip switch housing only. For enabling switch, see the HE5B specifications on page 13.
- The following switches can be installed on the grip switch housing to be used as hand-held switches.
  - AB6M pushbuttons (IP65, except for AB6M-V)
  - AS6M selector switches (IP65)
  - AS6M key selector switches (IP65)



## Notes:

- The HE9Z-GSH51 grip switch housing does not include the HE5B enabling switch. The enabling switch must be ordered separately.
- The HE5B enabling switch must be installed and wired to the HE9Z-GSH51 grip switch housing by the user. For information on wiring, see the instruction sheet supplied with the HE9Z-GSH51.

## Dimensions

### HE9Z-GSH51

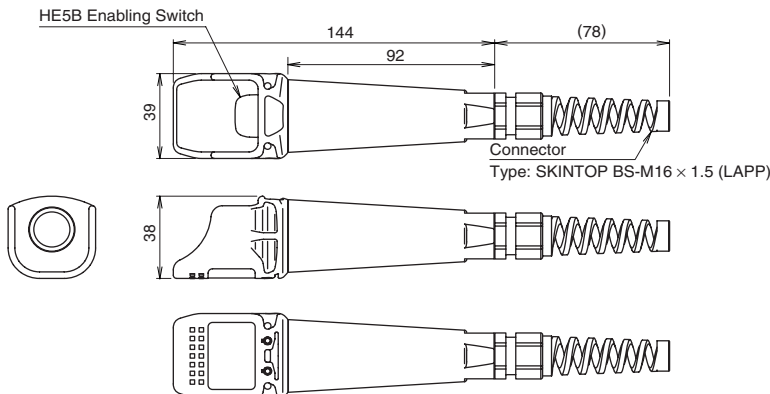

### HE9Z-GSH51 + HE5B Construction

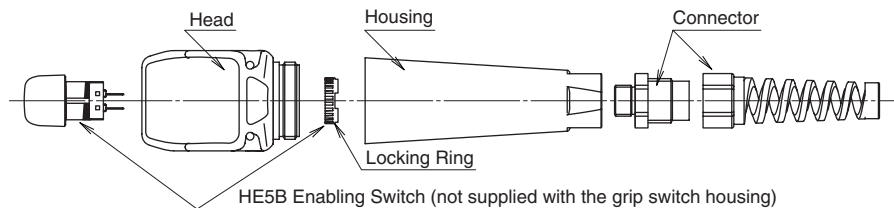

- Anti-rotation ring is not required when installing the HE5B enabling switch on the HE9Z-GSH51 grip switch housing. Use the locking ring only.

## • Mounting Bracket

Type No: HE9Z-GH1

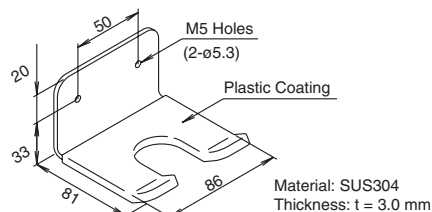

All dimensions in mm.

# HE1G Grip Switch

Ergonomically designed grip switch with two 3-position enabling switches.

- Ergonomically-designed OFF-ON-OFF operation.
- Direct opening action mechanism for shifting from position 2 (ON) to position 3 (OFF) (EN 60977-5-1/IEC 60947-5-1, Annex K).
- The switch does not turn ON when being released from position 3 (OFF when pressed) to position 1 (OFF when released) (IEC60204-1, 9.2.5.8).
- Two contacts are provided so that even if one contact fails due to welding or short-circuit, the other contact can disable machine operation.
- Emergency stop switch and momentary pushbutton versions are available.
- Conduit connector supplied.
- HE1G-21SM is IP66 waterproof.
- Can be used for applications required by the ANSI robot standard.



## Types

Contact Configuration			Rubber Boot	Ordering Type No.	Package Quantity
3-position Switch	Monitor Switch	Pushbutton			
2 contacts	With (1NC)	Without	Silicon Rubber / yellow	HE1G-21SM	1
			NBR / PVC Polyblend / gray	HE1G-21SM-1N	
		Momentary Pushbutton (1NO)	Silicon Rubber / yellow	HE1G-21SMB	
			NBR / PVC Polyblend / gray	HE1G-21SMB-1N	
	Without	Emergency Stop Switch (2NC)	Silicon Rubber / yellow	HE1G-20ME	
			NBR / PVC Polyblend / gray	HE1G-20ME-1N	
		Momentary Pushbutton (2NO)	Silicon Rubber / yellow	HE1G-20MB	
			NBR / PVC Polyblend / gray	HE1G-20MB-1N	

## Ratings

### • Contact Ratings

Rated Insulation Voltage (Ui)				250V (momentary pushbutton switch: 125V)		
Rated Thermal Current (Ith)				3A		
Rated Voltage (Ue)				30V	125V	250V
Rated Current (Ie)	3-position Switch (terminal No. 1-2, 3-4)	AC	Resistive Load (AC-12)	—	3A	1.5A
			Inductive Load (AC-15)	—	1.5A	0.75A
		DC	Resistive Load (DC-12)	2A	0.4A	0.2A
			Inductive Load (DC-13)	1A	0.22A	0.1A
	Monitor Switch (HE1G-21SM, terminal No. 5-6)	AC	Resistive Load (AC-12)	—	2A	1A
			Inductive Load (AC-15)	—	1A	0.5A
		DC	Resistive Load (DC-12)	2A	0.4A	0.2A
			Inductive Load (DC-13)	1A	0.22A	0.1A
	Emergency Stop Switch (HE1G-20ME, terminal No. 5-6, 7-8)	AC	Resistive Load (AC-12)	—	—	—
			Inductive Load (AC-15)	—	—	0.5A
		DC	Resistive Load (DC-12)	—	—	—
			Inductive Load (DC-13)	—	—	0.1A
Momentary Pushbutton Switch (HE1G-20MB, terminal No. 5-6, 7-8)	AC	Resistive Load (AC-12)	—	0.5A	—	
		Inductive Load (AC-15)	—	0.3A	—	
	DC	Resistive Load (DC-12)	1A	0.2A	—	
		Inductive Load (DC-13)	0.7A	0.1A	—	
Contact Configuration	3-position Switch	2 contacts				
	Monitor Switch	0 or 1 contact				
	Emergency Stop Switch	0 or 2 contacts				
	Momentary Pushbutton Switch	0 to 2 contacts				

- Minimum applicable load (reference value): 3V AC/DC, 5 mA
- Applicable operation area depends on the operating conditions and load.

## Specifications

Applicable Standards	IEC 60947-5-1, EN 60947-5-1 (BG approval), GS-ET-22 (BG approval), UL508 (UL listed), CSA C22.2, No. 14 (c-UL listed), JIS C8201-5-1
Applicable Standards for Use	ISO 12100 / EN 292, IEC 60204-1 / EN 60204-1, ISO11161 / prEN11161, ISO 10218 / EN 775, ANSI/RIA R15.06, ANSI B11.19
Operating Temperature	Silicon rubber boot: -25 to 60°C (no freezing) NBR/PVC Polyblend rubber boot: -10 to 60°C (no freezing)
Relative Humidity	45 to 85% (no condensation)
Storage Temperature	-40 to +80°C (no freezing)
Pollution Degree	3
Contact Resistance	100 mΩ maximum (initial value)
Insulation Resistance	Between live and dead metal parts: 100 MΩ minimum (500V DC megger) Between terminals of different pole: 100 MΩ minimum (500V DC megger)
Impulse Withstand Voltage	2.5 kV (except for momentary pushbuttons)
Electric Shock Protection Class	Class II (IEC 61140)
Operating Frequency	1,200 operations per hour
Mechanical Durability	Position 1 → 2 → 1: 1,000,000 operations minimum Position 1 → 2 → 3 → 1: 100,000 operations minimum
Electrical Durability	100,000 operations minimum
Shock Resistance	Operating extremes: 150 m/s <sup>2</sup> Damage limits: 1,000 m/s <sup>2</sup>
Vibration Resistance	Operating extremes: 5 to 55 Hz, amplitude 0.5 mm minimum Damage limits: 16.7 Hz, amplitude 1.5 mm minimum
Applicable Wire	0.14 to 1.5 mm <sup>2</sup>
Applicable Cable	Outside diameter ø7 to 13 mm
Conduit Size	M20 (connector is supplied with the grip switch)
Terminal Tensile Strength	20N minimum
Terminal Screw Tightening Torque	0.5 to 0.6 N·m
Degree of Protection	HE1G-21SM: IP66 (IEC 60529) HE1G-20ME: IP65 (IEC 60529) HE1G-20MB: IP65 (IEC 60529) HE1G-21SMB: IP65 (IEC 60529)
Conditional Short-circuit Current	50A (250V) (Use 250V/10A fast acting type fuse for short circuit protection.)
Weight (approx.)	HE1G-21SM: 210g HE1G-20ME: 250g HE1G-20MB: 220g

## Operating Characteristics

### • HE1G-21SM

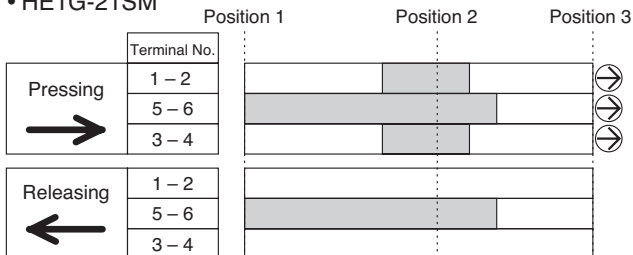

### • HE1G-20ME

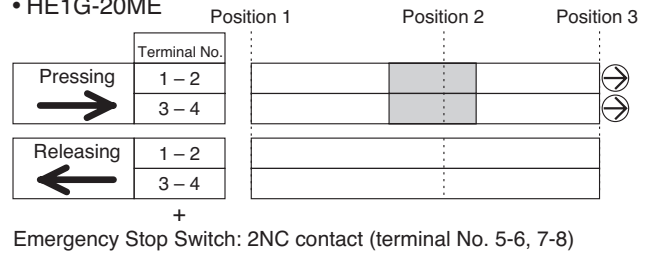

### • HE1G-21SMB

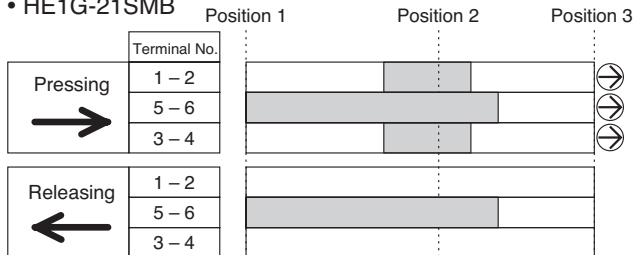

+

Momentary Pushbutton: 1NO contact (terminal No. 7-8)

: contact ON (closed)
  : contact OFF (open)

### Notes:

- 3-position switches operate with direct opening action (↻) when shifting from position 2 to position 3.
- For the output of the enabling device, use terminals 1-2 and 3-4.
- The above operation characteristics show when the center of the button is pressed.

# HE1G Grip Switch

## Dimensions

### • HE1G-21SM

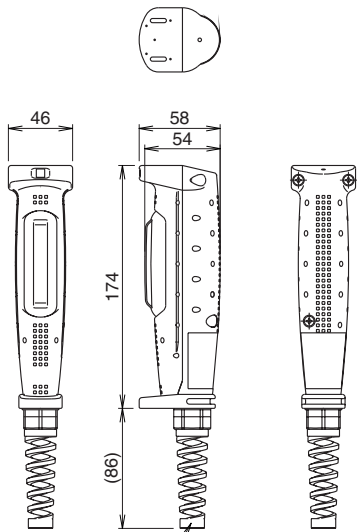

Connector (supplied with grip switch)  
Type No.: SKINTOP BS-M20 × 1.5 (LAPP)

### • HE1G-21SM

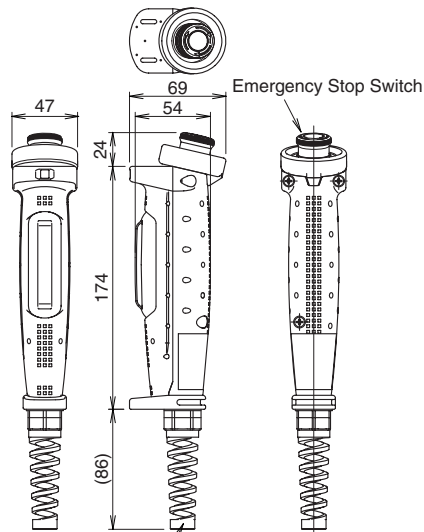

Connector (supplied with grip switch)  
Type No.: SKINTOP BS-M20 × 1.5 (LAPP)

### • HE1G-20MB / HE1G-21SMB

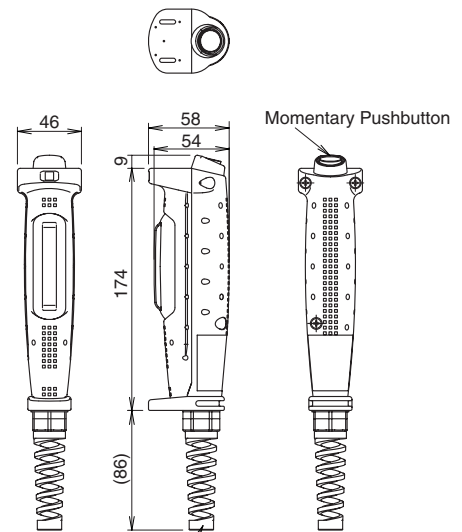

Connector (supplied with grip switch)  
Type No.: SKINTOP BS-M20 × 1.5 (LAPP)

## Accessories

### • Mounting Bracket (for hanging grip switch)

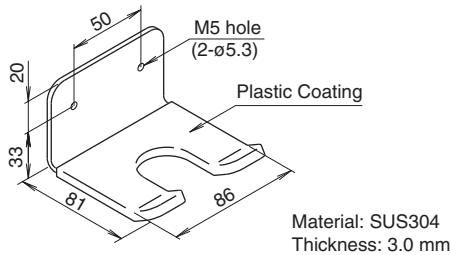

Material: SUS304  
Thickness: 3.0 mm

### • Rubber Boot Kit (replacement)



Rubber Boot Material	Type No.
Silicon Rubber / yellow	HE9Z-GBK1
NBR/PVC Polyblend / gray	HE9Z-GBK1-1N

All dimensions in mm.



## Safety Precautions

- Turn off power before starting installation, removal, wiring, maintenance, and inspection of HE1G grip switches. Failure to turn power off may cause electric shock or fire hazard.
- Install the HE1G grip switches according to the instructions on page 19 to achieve strength against operating force. Insufficient strength and excessive force may damage grip switches, resulting in possible electric shock or fire hazard.
- Use wires of the proper size to meet the voltage and current requirements. Solder the terminal properly according to the instructions on page 19. Improper soldering may cause overheating, resulting in fire hazard.

# Instructions for Enabling Switch and Grip Switch

## Instructions

### Installation Instructions

#### HE2B Enabling Switch with Rubber Boot

- The ridge on the bottom of rubber boot serves as a seal, and waterproof characteristics are attained when the ridge is tightly pressed to the mounting panel. When the mounting panel is bent and the ridge cannot be pressed to the panel, add a reinforcing rib to secure the boot to the mounting panel.
- The edge of rubber boot may stick out if excessive force is applied on the rubber boot. When such event is anticipated, it is recommended to embed the rubber boot in the mounting panel as shown in the figure below.

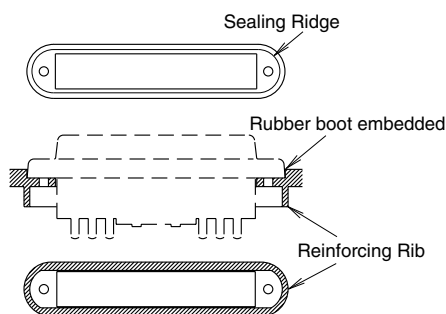

#### HE2B/HE3B/HE5B Enabling Switch with Rubber Boot

- When an enabling switch with rubber boot is mounted in a hermetically-sealed control box, a large change in internal air pressure may cause the rubber boot to inflate and deflate, affecting the performance of the enabling switch. Check periodically to make sure that the enabling switch operates correctly.

#### HE3B Enabling Switch with Rubber Boot

- If the mounting panel is deformed, waterproof characteristics of the enabling switch with rubber boot cannot be achieved. Keep sufficient strength on the mounting panel.
- The rubber boot has a projection for positioning the enabling switch onto the mounting panel. To maintain waterproof characteristics of the switch, do not drill through the anti-rotation hole in the mounting panel. When not providing the hole, remove the anti-rotation projection from the rubber boot. When removing the projection, ensure not to make a hole in the rubber boot.
- Secure the flange part when tightening the locking ring so that the enabling switch does not rotate. When the enabling switch may rotate during operation, it is recommended to embed the switch in the mounting panel as shown below.

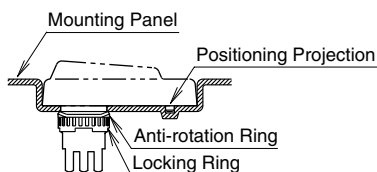

#### HE5B Enabling Switch with Rubber Boot

- If the mounting panel is deformed when mounting an enabling switch with rubber boot, the normal waterproof characteristics cannot be assured. Keep sufficient strength on the mounting panel.
- Do not press the rubber boot with excessive pressure in an inappropriate direction, otherwise the waterproof function can be damaged.

### Wiring Instructions

#### HE1B/HE2B/HE3B/HE5B Enabling Switch

- Applicable wire size: 0.5 mm<sup>2</sup> maximum × 1 pc.
- Solder the terminal at a temperature of 310 to 350°C within 3 seconds using a soldering iron. Sn-Ag-Cu type is recommended when using lead-free solder.
- When soldering, take care not to touch the enabling switch with the soldering iron. Also ensure that no tensile force is applied to the terminal. Do not bend the terminal or apply excessive force to the terminal.
- Use non-corrosive liquid rosin as soldering flux.

#### HE9Z-GSH51 Grip Switch Housing

##### • Recommended Tightening Torque

Parts for tightening		Torque
A	Head and body	1.0 ± 0.2 N·m
B	Body and connector	3.0 ± 0.3 N·m
C	Connectors	3.0 ± 0.3 N·m

Note: Recommended connector is used for the tightening torque of B and C. When using another connector, refer to the tightening torque of the connector used.

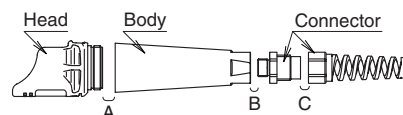

#### HE1G Grip Switch

##### • Wire Length inside the Grip Switch

	Terminal No. 1-4	Terminal No. 5-8
Wire length L1, L2 (mm)	L1 = 40 mm	L2 = 27 mm
Wire stripping length L3 (mm)	L3 = 6 mm	

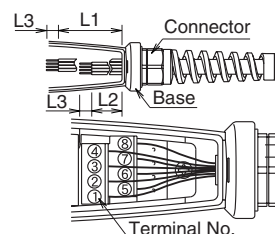

##### • Applicable Wire Size in Terminal

<Direct wiring>

0.14 to 1.5 mm<sup>2</sup> (one wire per terminal)

Note: When using stranded wire, make sure that adjoining terminals are not short-circuited by frayed wires. Also, do not solder the wires to avoid frayed wires.

<Ferrules>

Recommended ferrules (Phoenix Contact)

Type No.	Applicable Wire
AI 0,5-8 WH	0.34 to 0.5 mm <sup>2</sup>
AI 0,75-8 GY	0.5 to 0.75 mm <sup>2</sup>
AI 1,0-8 RD	0.75 to 1.0 mm <sup>2</sup>
AI 1,5-8 BK	1.0 to 1.5 mm <sup>2</sup>

Crimping tool: CRIMPFOX UD6

##### • Recommended Screw Tightening Torque

Parts for Tightening		Tightening Torque
A	Rubber boot and the base (M4 screw × 3)	1.2 ± 0.1 N·m
B	Connector and grip switch	4.0 ± 0.3 N·m
C	Connector and connector	4.0 ± 0.3 N·m
D	Terminal screw (M3 screw × 8)	0.5 to 0.6 N·m
E	Do not remove screws	—

The torque of screws B and C in the table above are values when the recommended connector is used. When using another connector, refer to the specifications of the connector used.

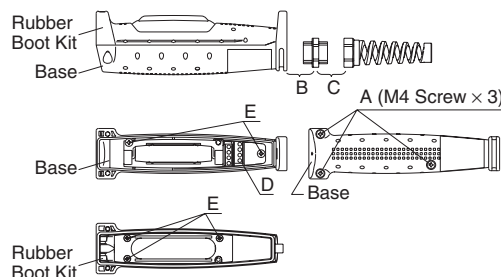

## Instructions

### Operating Instructions

#### HE2B/HE3B/HE5B Enabling Switch, HE1G Grip Switch

- To achieve a high level of safety, connect the two contacts of the 3-position switch to a disparity detection circuit (e.g., safety relay module) (ISO 13849-1, EN 954-1)
- Because two contacts are designed to operate independently, pressing the edge of a button turns on one contact earlier than the other contact, causing a delay in operation. To avoid this, always press the center of the button.

#### HE1B/HE2B/HE3B/HE5B Enabling Switch

- 3-position enabling switches output ON signals in position 2. Systems must be designed to enable machine operation when the 3-position enabling switch is in position 2 only.
- For operation of shifting the enabling switch from position 2 (ON) to position 3 (OFF), make sure that no load larger than specified is applied to the operator.
- For a teach pendants' shape and structure, perform sufficient risk assessment to prevent unintended operation of 3-position enabling switches (e.g., when the teach pendant is designed with a 3-position enabling switch protruding from the teach pendant, the switch may be initiated unintentionally if the teach pendant is placed with the side of enabling switch down).
- Strong force may be applied to a 3-position enabling switch when pressed to position 3. For teach pendants, provide sufficient strength to the part where 3-position enabling switches will be installed.



### Safety Precautions

- Read the operating instructions in the catalog or user's manual to ensure correct operation before starting installation, wiring, operation, maintenance, and inspection of the HE1B/2B/3B/5B enabling switches and HE1G grip switches.

Specifications and other descriptions in this catalog are subject to change without notice.



## IDEC CORPORATION

### IDEC CORPORATION (USA)

1175 Elko Drive, Sunnyvale, CA 94089-2209, USA  
Tel: +1-408-747-0550, Toll Free: (800) 262-IDEC, Fax: +1-408-744-9055  
E-mail: opencontact@idec.com

### IDEC CANADA LIMITED

Unit 22-151, Brunel Road Mississauga, Ontario, L4Z 1X3, Canada  
Tel: +1-905-890-8561, Toll Free: (888) 317-4332, Fax: +1-905-890-8562  
E-mail: sales@ca.idec.com

### IDEC ELECTRONICS LIMITED

Unit 2, Beechwood, Chineham Business Park, Basingstoke, Hampshire RG24 8WA, UK  
Tel: +44-1256-321000, Fax: +44-1256-327755  
E-mail: idec@uk.idec.com

### IDEC ELEKTROTECHNIK GmbH

Wendenstrasse 331, D-20537 Hamburg, Germany  
Tel: +49-40-25 30 54 10, Fax: +49-40-25 30 54 24  
E-mail: service@idec.de

### IDEC AUSTRALIA PTY. LTD.

2/3 Macro Court, Rowville, Victoria 3178, Australia  
Tel: +61-3-9763-3244, Toll Free: 1800-68-4332, Fax: +61-3-9763-3255

7-31, Nishi-Miyahara 1-Chome, Yodogawa-ku, Osaka 532-8550, Japan  
Tel: +81-6-6398-2571, Fax: +81-6-6392-9731  
E-mail: products@idec.co.jp

### IDEC IZUMI ASIA PTE. LTD.

No. 31, Tannery Lane #05-01, Dragon Land Building, Singapore 347788  
Tel: +65-6746-1155, Fax: +65-6844-5995  
E-mail: generalinfo@idecasia.com.sg

### IDEC IZUMI (H.K.) CO., LTD.

Unit 1505-07, DCH Commercial Centre No. 25, Westlands Road, Quarry Bay, Hong Kong  
Tel: +852-2803-8989, Fax: +852-2565-0171  
E-mail: idec@idechk.com

### IDEC (SHANGHAI) CORPORATION

Room 608-609, 6F, Gangtai Plaza, No. 700, Yan'an East Road, Shanghai 200030, China  
Tel: +86-21-5353-1000, Fax: +86-21-5353-1263  
E-mail: idec@cn.idec.com

### IDEC TAIWAN CORPORATION

8F, No. 79, Hsin Tai Wu Road, Sec. 1, Hsi-Chih, Taipei County, Taiwan  
Tel: +886-2-2698-3929, Fax: +886-2-2698-3931  
E-mail: service@idectwn.com.tw

www.idec.com

Cat. No. EP1045-0 DECEMBER 2005 14DNP PRINTED IN JAPAN

(05/12/07)