



Intrinsically Safe Explosion-proof

EB3C Relay Barriers

EB3L Lamp Barriers



Compact housing, low power consumption
A variety of control units can be connected.

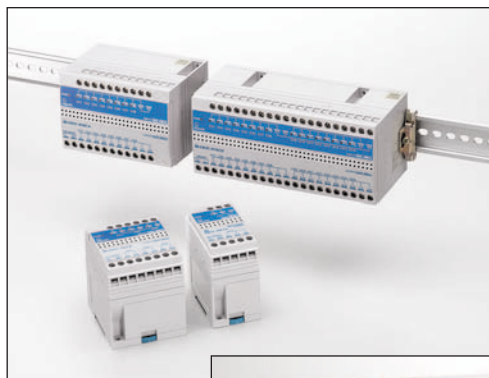

▲ Relay Barriers

▼ Lamp Barriers

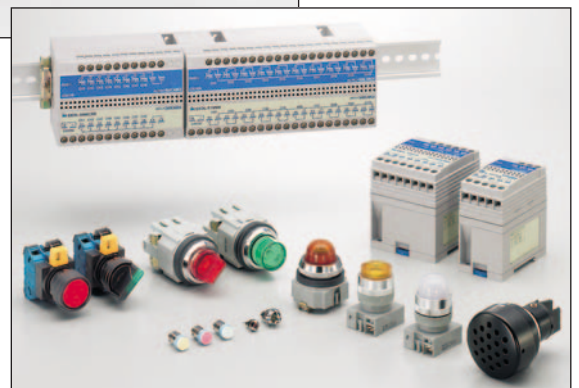

Easy-to-operate Intrinsically Safe Lamp Barriers for Worldwide

Compact and Lightweight

198 mm
171.5 mm
140 mm
75 mm

EB3C/EB3L (10-circuit)
0.4 kg
IBRC6101R
IBPL610-E
1.1 kg

46% footprint, 36% weight.
(Compared with IDEC's IBRC 10-circuit type)

No Grounding Required (AC/DC)

No grounding required

Worldwide Usage

- Universal AC power voltage (100 to 240V AC)
- Compliance with US, Canadian, European, and Japanese (TIIS) standards



Relay Barriers and Usage

Type EB3C

Type EB3L

Illuminated Pushbutton/Selector Switches can be used.

Illuminated pushbutton/selector switches can be used with the combination of EB3C and EB3L.



ClassNK

Approved for use on ship and other marine structures (Japan).



A Variety of Pilot Lights

ø6, ø8, ø10, ø22, and ø30 pilot lights can be connected to the EB3L.



Super-bright LED is used on ø22 and ø30 pilot lights.

Lens colors: Amber, blue, green, red, white, and yellow

Dry-contact switches with 0.5Ω maximum contact resistance can be connected to the EB3C.

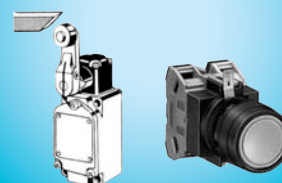

Connector Type

MIL connector on the non-intrinsically safe side.

- Easy connection to PLCs
- Wiring is cut by 90% (compared with IDEC's 16-circuit EB3C).
- Various 20-pin MIL connectors can be connected.

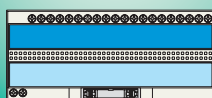

Buzzer can be connected to the EB3L

Continuous / intermittent buzzer sound available.



Common Wiring for PLC Inputs

8- and 16-circuit types are available in common wiring types, ideal for connection to PLCs.

Spring-up Fingersafe Terminals Reduce Wiring Time

Spring-up structure Fingersafe

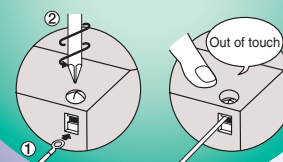

EB3C Relay Barrier

Input contacts can be used in any explosive gas and Zone 0/Class I Div. 1 areas.

Explosion protection	
Relay Barrier:	[Exia] II C
Switch:	Exia II CT6 or Exia II BT6

- IEC60079 compliant
- Dry-contact switches with 0.5Ω maximum contact resistance can be connected to the EB3C.
- Compact and lightweight (46% footprint and 36% weight compared to IDEC's 10-circuit IBRC)
- 8- and 16-circuit types are available in common wiring types, ideal for connection to PLCs. 16-circuit types are also available with a connector.
- Universal AC power voltage (100 to 240V AC)
- No grounding required
- IDEC's original spring-up terminal minimizes wiring time.
- Installation
35-mm-wide DIN rail mounting or direct screw mounting
- Global usage
USA: FM
Canada: CSA
Europe: CE marking, ATEX
Japan: TIIS
- Ship class: ClassNK (Japan)

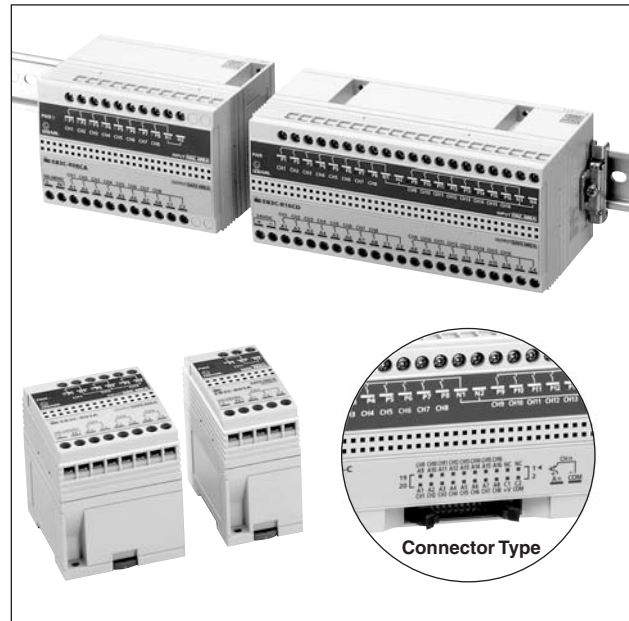

Types

Power Voltage	Number of Channels	Connection to Non-intrinsically Safe Circuit	Input Wiring Method	Output	Type No.		
100 to 240V AC	1	Screw Terminal	Separate/Common Wiring Compatible	Relay	EB3C-R01A		
	2				EB3C-R02A		
	3				EB3C-R03A		
	5				EB3C-R05A		
	6				EB3C-R06A		
	8		EB3C-R08A				
	10		EB3C-R10A				
	8		EB3C-R08CA				
	6		EB3C-T06A				
	8		EB3C-T08A				
24V DC	10	Screw Terminal	Separate/Common Wiring Compatible	Transistor (Sink/Source)	EB3C-T10A		
	16				EB3C-T16A		
	8				EB3C-T08CKA		
	8				EB3C-R08CD		
	10				EB3C-R10D		
	16		EB3C-R16CD				
	10		Common Wiring Only	Transistor (Sink/Source)	Relay	EB3C-T10D	
	8					Sink	EB3C-T08CKD
	16						EB3C-T16CKD
	8					Source	EB3C-T08CSD
16	EB3C-T16CSD						
16	Sink	EB3C-T16CKD-C					
16		Source	EB3C-T16CSD-C				
	16	Connector					

Accessories

Name	Type No.	Order No.	Package Quantity	Description
DIN Rail	BAA1000	BAA1000PN10	10	Aluminum (1 m long)
	BAP1000	BAP1000PN10	10	Steel (1 m long)
Mounting Clip	BNL5	BNL5PN10	10	For fastening EB3C units on the DIN rail.
	BNL6	BNL6PN10	10	

EB3C Relay Barrier

Explosion-Protection and Electrical Specifications

Explosion Protection		Intrinsic safety type (IEC compliant) [Exia] II C			
Degree of Protection		IP20 (IEC60529)			
Installation Location	Relay Barrier	Safe indoor place (non-hazardous area)			
	Switch	For zone 0, 1, 2 hazardous areas			
Non-intrinsically Safe Circuit Maximum Voltage (Um)		250V AC 50/60Hz, 250V DC			
Intrinsically Safe Circuits	Wiring Method	1-channel Separate Wiring	16-channel Common Wiring		
	Rated Operating Voltage	12V DC $\pm 10\%$			
	Rated Operating Current	10 mA DC $\pm 20\%$			
	Maximum Output Voltage (Uo)	13.2V DC			
	Maximum Output Current (Io)	14.2 mA	227.2 mA		
	Maximum Output Power (Po)	46.9 mW	750 mW		
	Maximum External Inductance (Lo) (Note)	175 (125) mH	0.68 (0.68) mH		
	Maximum External Capacitance (Co) (Note)	900 (740) nF			
	Allowable Wiring Resistance (Rw)	300 Ω	600/(n+1) Ω (n = number of common channels)		
	Maximum Channels per Common Line	—	16		
Non-intrinsically Safe Circuits	Contact Configuration	1NO			
		Rated Insulation Voltage (Ui)			
		Thermal Current (Ith)			
	Contact Allowable Power	Resistive Load	AC: 750 VA, DC: 72W		
			Inductive Load	AC: 750 VA (cos $\phi = 0.3$ to 0.4) DC: 48W (L/R = 7 ms)	
		Rated Load		Resistive Load	250V AC 3A, 24V DC 3A
			Inductive Load		250V AC 3A (cos $\phi = 0.3$ to 0.4) 24V DC 2A (L/R = 7 ms)
	Minimum Applicable Load			0.1V DC, 0.1 mA (reference value)	
	Contact Resistance		50 m Ω maximum (initial value)		
	Turn ON Time		12 ms maximum (rated voltage)		
	Turn OFF Time		10 ms maximum (rated voltage)		
	Mechanical Life		20,000,000 operations minimum (at 18,000 operations/hour, without load)		
	Electrical Life		100,000 operations minimum (at 1,800 operations/hour, rated load)		
	Short-circuit Protection		None		
	Transistor Output	Rated Voltage		24V DC	
		Maximum Voltage		30V DC	
		Maximum Current		100 mA (connector type: 15 mA)	
		Leakage Current		0.1 mA maximum	
		Voltage Drop		1V maximum	
		Clamping Voltage		33V (1W)	
Inrush Current		0.5A maximum (1 sec)			
Turn ON Time		0.1 ms maximum (resistive load)			
Turn OFF Time		0.4 ms (typical) (resistive load)			
Short-circuit Protection		None			

Note: Values in () are those approved by TIIS (Technology Institution of Industrial Safety, Japan).

Certification No.

Certification Organization	Explosion Protection	Certification No.
FM	Class I, II, III Div. 1 Group A, B, C, D, E, F, G	3015417 (terminal type) 3019223 (connector type)
	Class I, Zone 0 AEx [ia] IIC	
CSA	Class I Div. 1 Group A, B, C, D	166730
NEMKO	[EExia] II C	Nemko 02ATEX279
TIIS Japan	Relay barrier: [Exia] II C	C15753
	Switch (EB9Z-A): Exia II CT6	C15758
	Switch (EB9Z-A1): Exia II BT6	C15961
ClassNK	Exia II C	02T606

Note: For details about switches, see "Switch Explosion-Protection Specifications" on page 5 and "3. Switches in the Hazardous Area" on page 9.

General Specifications

Power Voltage Type	AC Power Type	DC Power Type
Rated Power Voltage	100 to 240V AC	24V DC
Allowable Voltage Range	85 to 264V AC	21.6 to 26.4V DC
Rated Frequency	50/60 Hz (allowable range: 47 to 63 Hz)	—
Inrush Current	10A (100V AC) 20A (200V AC)	10A
Dielectric Strength (1 minute, 1 mA)	Between intrinsically safe circuit and non-intrinsically safe circuit: 1500V AC	
	Between AC power and output terminal: 1500V AC	
	Between DC power and transistor output terminal: 1000V AC	
Operating Temperature	-20 to +60°C (no freezing)	
Storage Temperature	-20 to +60°C (no freezing)	
Operating Humidity	45 to 85% RH (no condensation)	
Atmosphere	800 to 1100 hPa	
Pollution Degree	2 (IEC60664)	
Insulation Resistance		
10 M Ω minimum (500V DC megger, between the same poles as the dielectric strength)		
Vibration Resistance	Damage Limits	
	Operation Extremes (relay output only)	
Shock Resistance	Damage Limits	
	Terminal Style	
Mounting	M3 screw terminal	
Power Consumption (approx.)	35-mm-wide DIN rail or panel mounting (M4 screw)	
Weight (approx.)	9.6 VA (EB3C-R10A at 200V AC) 4.8 W (EB3C-R16CD at 24V DC)	
	0.39 kg (EB3C-R16CD)	

Switch Explosion-Protection Specifications (TIIS Japan)

Simple apparatuses in accordance with relevant standards of each country can be installed in the hazardous area and connected to the EB3C located in the safe area. In Japan, any switches, though regarded as simple apparatuses, must be certified for explosion-proof devices. EB9Z-A and EB9Z-A1 are IDEC's generic Type No. of any single apparatuses certified by TIIS Japan for use with the EB3C, therefore simple apparatuses with specifications shown below can be used as those approved by the Japanese explosion-proof certification.

Switch Type No.	EB9Z-A	EB9Z-A1			
Explosion Proof	Exia II CT6	Exia II BT6			
Operating Temperature	-20 to +60°C (no freezing)				
Operating Humidity	45 to 85% RH (no condensation)				
Degree of Protection	IP20				
Dielectric Strength	500V AC, 1 mA				
Intrinsic Safety Ratings and Parameters	1-channel Separate Wiring Maximum input voltage (Ui): 13.2V Maximum input current (Ii): 14.2 mA Maximum input power (Pi): 46.9 mW Internal inductance (Li): $\leq 5 \mu\text{H}$ Internal capacitance (Ci): $\leq 2 \text{ nF}$				
	16-channel Common Wiring Maximum input voltage (Ui): 13.2V Maximum input current (Ii): 227.2 mA Maximum input power (Pi): 750 mW Internal inductance (Li): $\leq 80 \mu\text{H}$ Internal capacitance (Ci): $\leq 32 \text{ nF}$				
Enclosure Material	Metallic: Magnesium content must be 6% or less (steel and aluminum are acceptable)				
	Plastic: Switch operator exposed area IIC: 20 cm ² maximum IIB: 100 cm ² maximum When the switch has a wider exposed area, attach a caution label as shown at right.	<table border="1"> <tr> <td>Caution</td> </tr> <tr> <td>To prevent electrostatic charges, do not rub the switch surface during operation. Use a soft cloth dipped with water for cleaning.</td> </tr> <tr> <td>Caution Label Example</td> </tr> </table>		Caution	To prevent electrostatic charges, do not rub the switch surface during operation. Use a soft cloth dipped with water for cleaning.
Caution					
To prevent electrostatic charges, do not rub the switch surface during operation. Use a soft cloth dipped with water for cleaning.					
Caution Label Example					
Switch Ratings	Contact rating: Ui, Ii minimum Contact resistance: 0.5 Ω maximum Cross sectional area of wire: 0.000962 mm ² maximum Printed circuit board: Thickness 0.5 mm minimum Copper foil width 0.15 mm minimum Thickness 18 μm minimum one/both side(s)				
	A resistor to prevent contact welding and an LED can be connected to 1-channel separate wiring circuits. Consult IDEC for details.				

Note: For details, see "3. Switches in the Hazardous Area" on page 9.

EB3C Relay Barrier

Internal Circuit Block Diagram

• AC Power, Relay Output Type

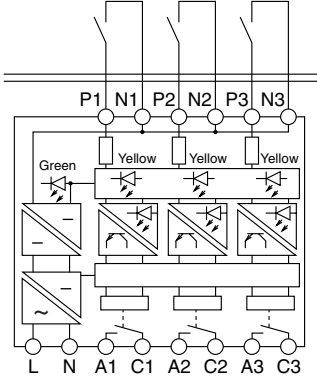

• DC Power, Transistor Output Type

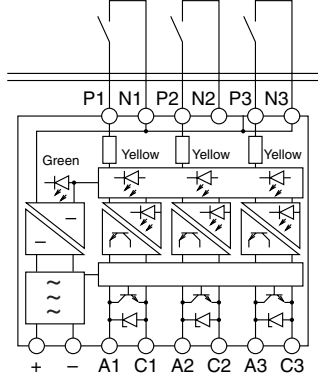

• Connector Wiring, Sink Output Type

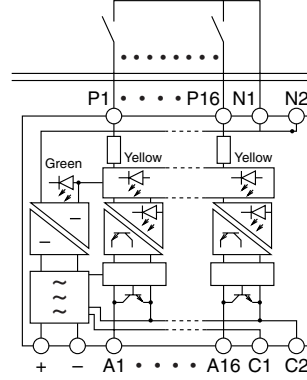

Hazardous Area
Non-hazardous Area

Dimensions

• Screw Terminal Type

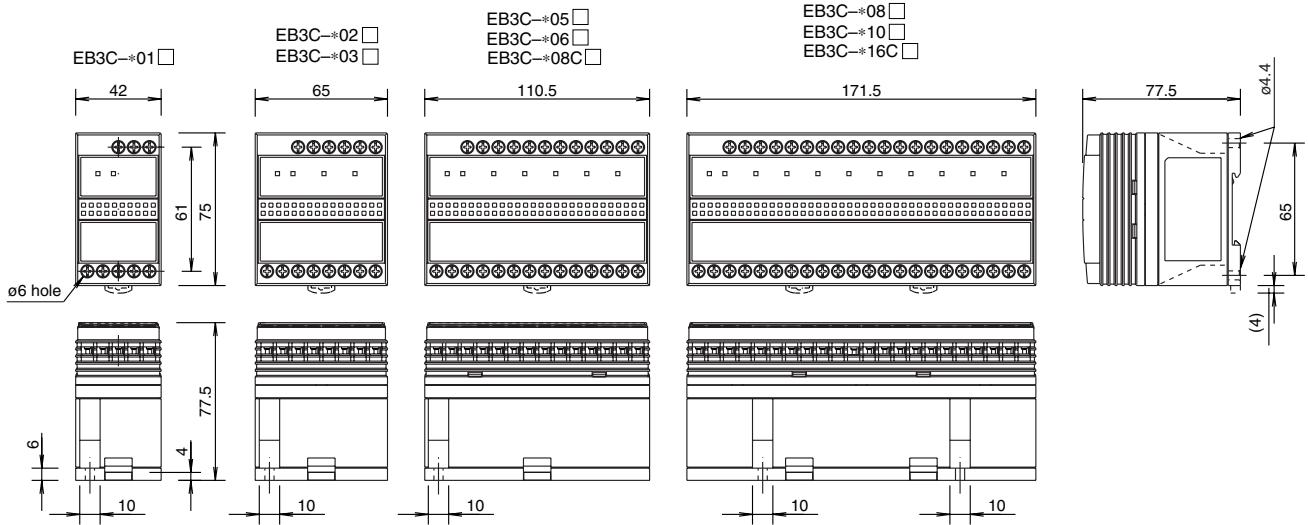

Mounting Hole Layout (Screw Mounting)

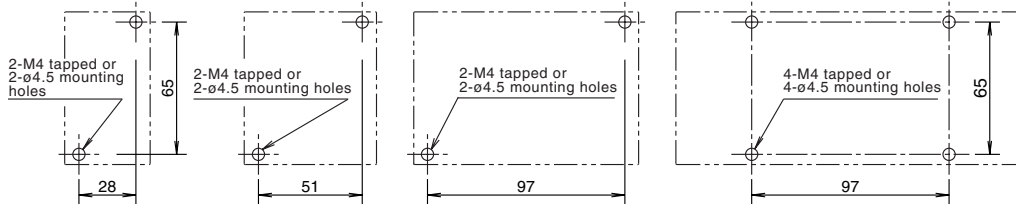

• Connector Type

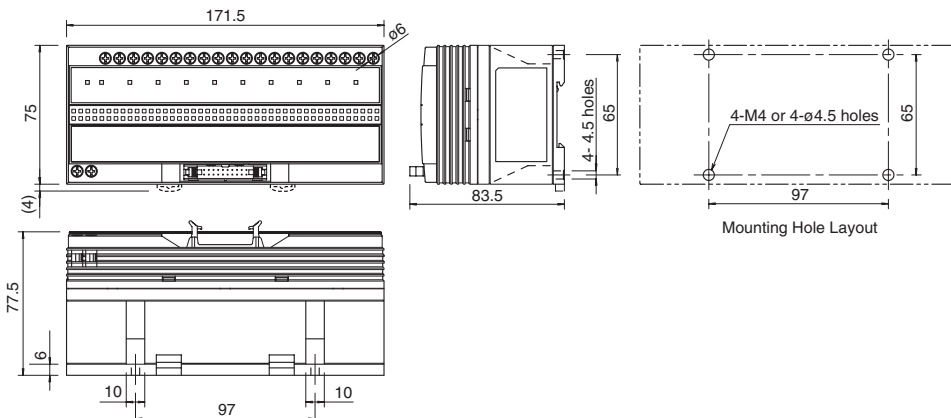

Applicable Crimping Terminal

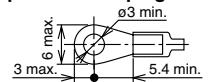

Stripping the Wire End

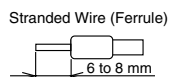
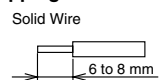

All dimensions in mm.

EB3C Relay Barrier

External Wiring Examples

• Transistor Sink Output Type (Ex.: EB3C-T08CKD)

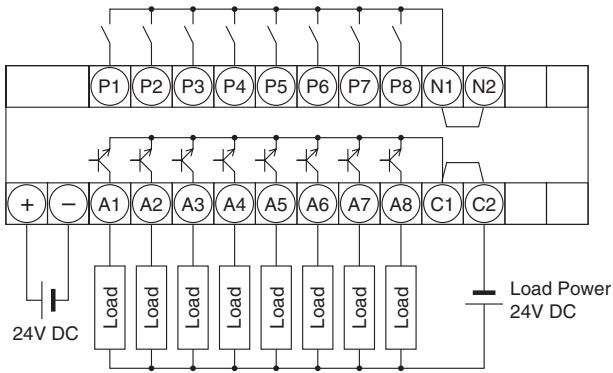

• Transistor Source Output Type (Ex.: EB3C-T08CSD)

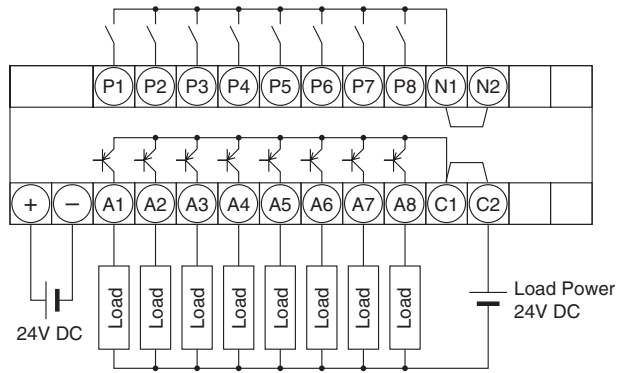

• Relay Output Type (Ex.: EB3C-R06A)

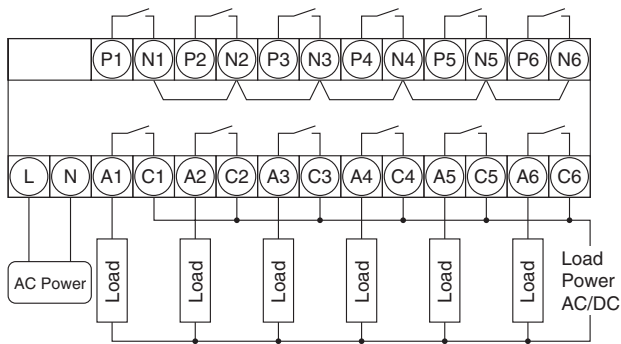

• Transistor Output Type (Ex.: EB3C-T06A)

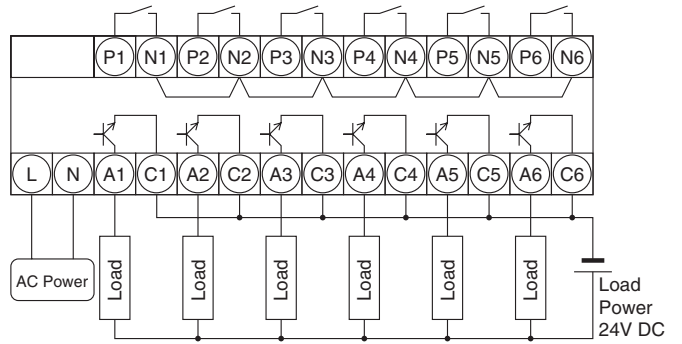

Connector Type Output Wiring Diagram

• EB3C-T16CKD-C

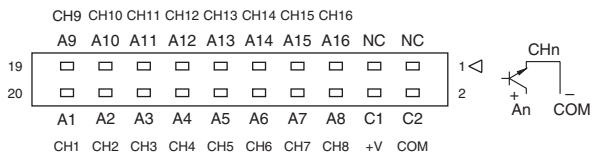

• EB3C-T16CSD-C

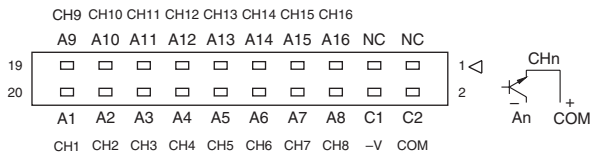

Wiring Example with IDEC's PLC MicroSmart

EB3C-T16CKD-C		FC4A-N16B3		EB3C-T16CSD-C		FC4A-N16B3	
Terminal	Output	Input	Terminal	Terminal	Output	Input	Terminal
20	A1	I0	20	20	A1	I0	20
19	A9	I10	19	19	A9	I10	19
18	A2	I1	18	18	A2	I1	18
17	A10	I11	17	17	A10	I11	17
16	A3	I2	16	16	A3	I2	16
15	A11	I12	15	15	A11	I12	15
14	A4	I3	14	14	A4	I3	14
13	A12	I13	13	13	A12	I13	13
12	A5	I4	12	12	A5	I4	12
11	A13	I14	11	11	A13	I14	11
10	A6	I5	10	10	A6	I5	10
9	A14	I15	9	9	A14	I15	9
8	A7	I6	8	8	A7	I6	8
7	A15	I16	7	7	A15	I16	7
6	A8	I7	6	6	A8	I7	6
5	A16	I17	5	5	A16	I17	5
4	+V	COM	4	4	-V	COM	4
3	NC	COM	3	3	NC	COM	3
2	COM(-)	NC	2	2	COM(+)	NC	2
1	NC	NC	1	1	NC	NC	1

Note 1: The wiring in dashed line does not affect the operation of the MicroSmart.

Note 2: Applicable connector is IDEC's JE1S-201.

EB3C Relay Barrier

Wiring

1. Separate Wiring

- Each input line of the EB3C makes up one independent intrinsically safe circuit.

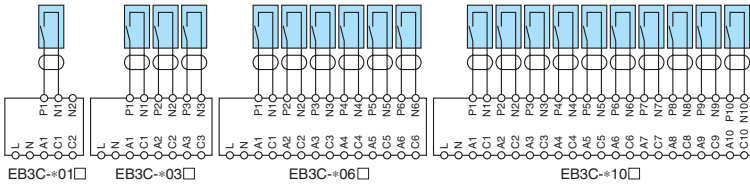
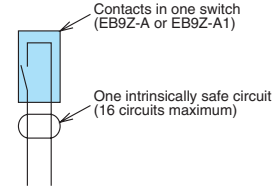
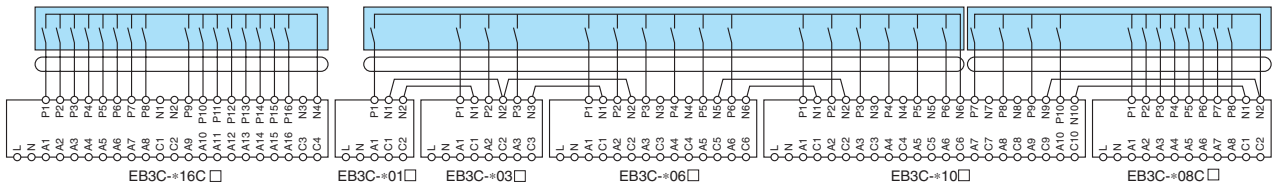

Diagram Symbols



2. Common Wiring (Maximum 16 circuits)

- All input lines are wired to a common line inside the intrinsically safe switch (one common line per intrinsically safe circuit).



- Some input lines are wired to a common line inside the intrinsically safe switches, while others are outside the switches (one common line per intrinsically safe circuit).

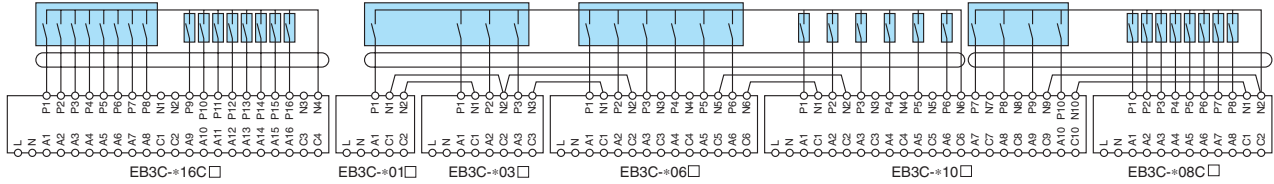

- All input lines are wired to a common line outside the intrinsically safe switches (one common line per intrinsically safe circuit).

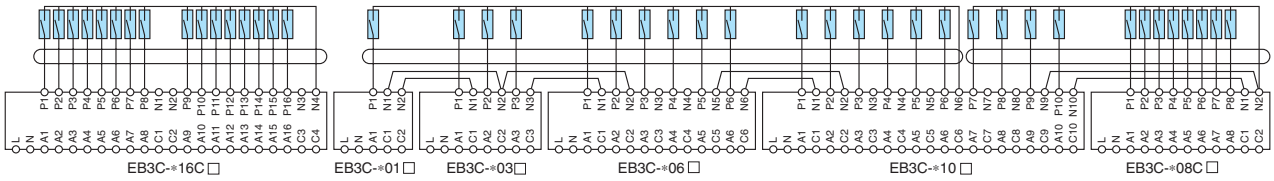

Recommended Connector Cable for Connector Types

Description	No. of Poles	Length (m)	Type No.	Appearance	Applicable Type
I/O Terminal Cable	With Shield	0.5	FC9Z-H050A20		MicroSmart I/O Module
		1	FC9Z-H100A20		
		2	FC9Z-H200A20		
		3	FC9Z-H300A20		
I/O Terminal Cable	Without Shield	0.5	FC9Z-H050B20		MicroSmart I/O Module
		1	FC9Z-H100B20		
		2	FC9Z-H200B20		
		3	FC9Z-H300B20		
Cable with Crimping Terminal		1	BX9Z-H100E4		Screw Terminal Type
		2	BX9Z-H200E4		
		3	BX9Z-H300E4		
40-pin Cable for PLC		1	BX9Z-H100L		Mitsubishi A, Q Series Input Module (positive common) ↓ EB3C-T16CKD-C
		2	BX9Z-H200L		
		3	BX9Z-H300L		

Precautions for Operation

1. Installation of EB3C Relay Barriers

- (1) The EB3C can be installed in any direction.
- (2) Install the EB3C relay barrier in a safe area (non-hazardous area) in accordance with intrinsic safety ratings and parameters. To avoid mechanical shocks, install the EB3C in an enclosure which suppresses shocks.
- (3) When installing or wiring the EB3C, prevent electromagnetic and electrostatic inductions in the intrinsically safe circuit. Also prevent the intrinsically safe circuits from contacting with another intrinsically safe circuit and any other circuits.

Maintain at least 50 mm clearance, or provide a metallic separating board between the intrinsically safe circuit and non-intrinsically safe circuit. When providing a metallic separating board, make sure that the board fits closely to the enclosure (top, bottom, and both sides). Allowable clearance between the enclosure and board is 1.5 mm at the maximum.

The clearance of 50 mm between the intrinsically safe circuit and non-intrinsically safe circuit may not be sufficient when a motor circuit or high-voltage circuit is installed nearby. In this case, provide a wider clearance between the circuits referring to 5 (3) "Minimum Parallel Distance between the Intrinsically Safe Circuit and Other Circuits."

- (4) In order to prevent contact between intrinsically safe circuits and non-intrinsically safe circuits, mount EB3C units with terminals arranged in the same direction.

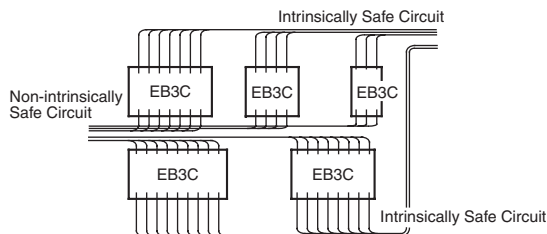

- (5) Maintain at least 6 mm (or 3 mm according to IEC60079-11: 1999) clearance between the terminal of intrinsically safe circuit and the grounded metal part of a metal enclosure, and between the relay terminal block of an intrinsically safe circuit and the grounded metal part of a metal enclosure.
- (6) For installing the EB3C, mount on a 35-mm-wide DIN rail or directly on a panel using screws. Make sure to install securely to withstand vibration. When mounting on a DIN rail, push in the clamp completely. Use the BNL5 or BNL6 mounting clips on both sides of the EB3C to prevent from moving sideways.
- (7) Excessive extraneous noise may cause malfunction and damage to the EB3C. When extraneous noise activates the voltage limiting circuit (thyristor), remove the noise source and restore the power.

2. Terminal Wiring

- (1) Using a $\phi 5.5$ mm or smaller screw driver, tighten the terminal screws (including unused terminal screws) to a torque of 0.6 to 1.0 N·m (recommended value).
- (2) Make sure that IP20 is achieved when wiring. Use insulation tubes on bare crimping terminals.
- (3) To prevent disengaged wires from contacting with other intrinsically safe circuits, bind together the wires of one intrinsically safe circuit.
- (4) When the adjacent terminal is connected to another intrinsically safe circuit, provide an insulation distance of at least 6 mm.

3. Switches in the Hazardous Area (For Japan application only)

- (1) A switch contains the switch contact, enclosure, and internal wiring. A switch contact refers to an ordinary switching device which consists of contacts only, such as a pushbutton switch. See below.

Applicable Switches

Control Switches	Push-pull Switches	Pushbutton, Foot, Trigger, Rocker, Grip
	Twisting Switches	Rotary, Selector, Cam, Drum, Thumb wheel
	Lever and Slide Switches	Toggle, Multidirectional, Wobble stick, Lever, Slide switch
Sensing Switches	Displacement Switches	Microswitch, Limit, Magnetic proximity, Door, Reed, Mercury
	Level Switches	Liquid level
	Others	Pressure, Temperature

Note: For installation in hazardous areas and connection to the EB3C, use switches which are certified, approved, or considered to be simple apparatus in relevant standards in each country.

- (2) When the switch has internal wiring or lead wire, make sure that the values of internal inductance (Li) and capacitance (Ci) are within the certified values.
- (3) Enclose the switch contact's bare live part in an enclosure of IP20 or higher protection.
- (4) Depending on the explosion-protection specifications according to TIIS Japan, the exposed area of plastic switch operator is limited as follows:
 - Exia II CT6 (EB9Z-A): 20 cm² maximum
 - Exia II BT6 (EB9Z-A1): 100 cm² maximum
- (5) Attach the certification mark supplied with the EB3C on the EB9Z-A or EB9Z-A1 switch (for Japan application).
- (6) Magnesium content of metallic enclosure must be 6% or less (steel and aluminum are acceptable).
- (7) When the switch operator of plastic enclosure has a wider exposed area than the following limits, attach a caution label as shown below.

IIC: 20 cm² maximum
IIB: 100 cm² maximum

Caution
To prevent electrostatic charges, do not rub the switch surface during operation. Use a soft cloth dipped with water for cleaning.

Caution Label Example

- (8) For the 1-circuit separate wiring, a resistor to prevent reed switch contact welding and an LED miniature pilot lights can be connected in series with the contact. See below. Use the terminal screw of M3 or larger.

Applicable Resistor Ratings

Resistance	100 Ω maximum
Rated Wattage	0.5 to 3W
Type	Metal (oxide) film resistors

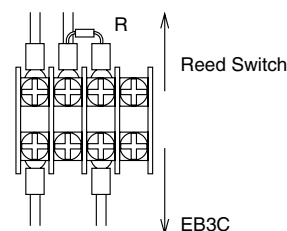

- Applicable LED Type
IDEC's IPL1 series LED miniature pilot lights.

EB3C Relay Barrier

Precautions for Operation

4. Output Specifications

- (1) When wiring the output from the EB3C, connect the non-intrinsically safe circuit to terminals A and C. The EB3C output circuit is not equipped with short-circuit protection. If required, provide a protection in the external circuit.
- (2) Relay Output
Some types of loads generate reverse emf (such as solenoids) or cause a large inrush current (incandescent lamps), resulting in a shorter operation life of output relay contacts. The operation life of contacts can be extended by preventing the reverse emf using a diode, RC, or varistor, or by suppressing the inrush current using a resistor or RL.
Contacts are made of gold-clad silver. When using at a small current and a low voltage (reference value: 0.1 mA, 0.1V), test the contact on the actual circuit in advance.

(3) Transistor Output

When connecting a small load, the load may not turn off because of a leakage current, even though the transistor output is turned off. If this is the case, connect a resistor in parallel with the load to bypass the leakage current.
When an excessively high voltage (clamps at 33V, 1W) or a reverse voltage is applied to the output terminals, the clamping circuit or output transistor may be damaged.
When driving an inductive load, be sure to connect a diode across the load to absorb reverse emf.

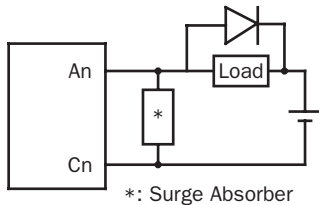

Example of Overvoltage Absorption Circuit

- (4) In the common wiring only types, the output terminals are not isolated from each other.
- (5) When connecting the connector type EB3C's in parallel, use one power supply to power the EB3C's. Do not connect any wiring to the C1 and C2 terminals.

5. Wiring for Intrinsic Safety

- (1) The voltage applied on the general circuit connected to the non-intrinsically safe circuit terminals of the EB3C relay barrier must be 250V AC, 50/60Hz, or 250V DC at the maximum under any conditions, including the voltage of the input power and the internal circuit.
- (2) When wiring, take into consideration the prevention of electromagnetic and electrostatic charges on intrinsically safe circuits. Also, prevent intrinsically safe circuits from contacting with other circuits.
- (3) The intrinsically safe circuits must be separated from non-intrinsically safe circuits. Contain intrinsically safe circuits in a metallic tube or duct, or separate the intrinsically safe circuits referring to the table below.

Note: Cables with a magnetic shield, such as a metallic sheath, prevent electromagnetic induction and electrostatic induction, however, a non-magnetic shield prevents electrostatic induction only. For non-magnetic shields, take a preventive measure against electromagnetic induction.

Finely twisted pair cables prevent electromagnetic induction. Adding shields to the twisted pair cables provides protection against electrostatic induction.

Minimum Parallel Distance between the Intrinsically Safe Circuit and Other Circuits (mm)

Voltage and Current of Other Circuits	Over 100A	100A or less	50A or less	10A or less
Over 440V	2000	2000	2000	2000
440V or less	2000	600	600	600
220V or less	2000	600	600	500
110V or less	2000	600	500	300
60V or less	2000	500	300	150

- (4) When identifying intrinsically safe circuits by color, use light blue terminal blocks and cables.
- (5) When using two or more EB3C's to set up one intrinsically safe circuit in the common wiring configuration, interconnect two neutral terminals (N1 through N10) on each EB3C between adjacent EB3C's in parallel.
- (6) Make sure that the power of the EB3C and contact are turned off before starting inspection or replacement.

Note: For the details of wiring the intrinsically safe circuits, refer to a relevant test guideline for explosion-proof electric equipment in each country.

EB3L Lamp Barrier

120 types of pilot lights and buzzers can be connected.

Illuminated pushbuttons and illuminated selector switches can be connected by combining with the EB3C relay barrier.

No grounding required.

Explosion protection	
Lamp Barrier	[Exia] II C
Pilot Light (separate wiring)	Exia II CT6
Pilot Light (common wiring)	Exia II CT4
Illuminated Pushbutton	Exia II CT4
Illuminated Selector Switch	Exia II CT4
Buzzer (separate wiring)	Exia II CT6

- IEC60079 compliant
- Compact and lightweight (46% footprint and 36% weight compared to IDEC's 10-circuit IBPL)
- 8- and 16-circuit types are available in common wiring types, ideal for connection to PLCs. 16-circuit types are also available with a connector.
- Universal AC power voltage (100 to 240V AC)
- No grounding required
- IDEC's original spring-up terminal minimizes wiring time.
- Installation
35-mm-wide DIN rail mounting or direct screw mounting
- $\phi 6$, $\phi 8$, $\phi 10$, $\phi 22$ and $\phi 30$ pilot lights available
- Illuminated pushbuttons and illuminated selector switches can be connected by combining with the EB3C relay barrier.
Illumination colors: Amber, blue, green, red, white, and yellow (pushlock turn reset type: red only)
- Continuous and intermittent sound types are available for buzzers ($\phi 30$).
- Global usage
USA: FM
Canada: CSA
Europe: CE marking, ATEX
Japan: TIIS
- Ship class: ClassNK (Japan)

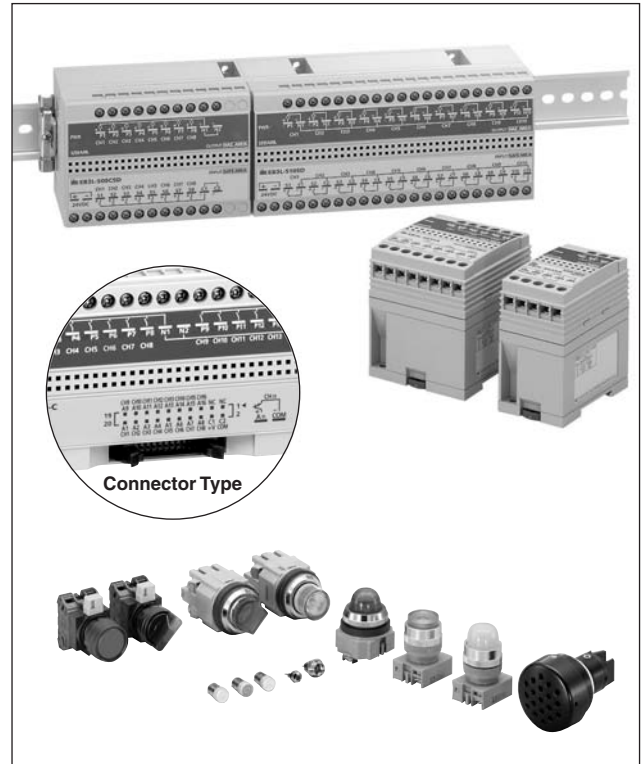

Types

Power Voltage	Number of Channels	Connection to Non-intrinsically Safe Circuit	Input Wiring Method	Output	Type No.	
100 to 240V AC	1	Screw Terminal	Separate/Common Wiring Compatible	Source	EB3L-S01SA	
	2				EB3L-S02SA	
	3				EB3L-S03SA	
	6				EB3L-S06SA	
	10				EB3L-S10SA	
24V DC	8	Screw Terminal	Common Wiring Only Separate/Common Wiring Compatible	Transistor	EB3L-S10KA	
	10				EB3L-S08CSD	
	16				EB3L-S10SD	
	Connector	Common Wiring Only	Common Wiring Only	Transistor	Sink	EB3L-S16CSD
					Source	EB3L-S16CKD
					Sink	EB3L-S16CSD-C
					Source	EB3L-S16CKD-C

Accessories

Name	Type No.	Order No.	Package Quantity	Description
DIN Rail	BAA1000	BAA1000PN10	10	Aluminum (1 m long)
	BAP1000	BAP1000PN10	10	Steel (1 m long)
Mounting Clip	BNL5	BNL5PN10	10	For fastening EB3L units on the DIN rail.
	BNL6	BNL6PN10	10	

EB3L Lamp Barrier

• Pilot Lights, Illuminated Pushbuttons, Illuminated Selector Switches, and Buzzers

Type	Size	Series (Note 1)	Shape	Operation Mode	Contact	Type No. (Note 2)	Lens Color/ Illumination Color Code*	Operation			
Pilot Light	ø30	N	Dome	—	—	EB3P-LAN1-*	A: Amber G: Green R: Red S: Blue W: White Y: Yellow	—			
			Dome w/Diecast Sleeve	—	—	EB3P-LAD1-*					
			Square	—	—	EB3P-LUN3B-*					
	ø22	TW	Flush	—	—	EB3P-LAW1-*					
			Flush (Marking Type)	—	—	EB3P-LAW1B-*					
			Dome	—	—	EB3P-LAW2-*					
			Square Flush (Marking Type)	—	—	EB3P-LUW1B-*					
			Round Flush	—	—	EB3P-LHW1-*					
		HW	Dome	—	—	EB3P-LHW2-*					
			Square Flush	—	—	EB3P-LHW4-*					
			LW	Round	—	—			EB3P-LLW1-*		
		Square		—	—	EB3P-LLW2-*					
	Miniature Pilot Light	ø10	UP	Extended	—	—			IPL1-18-*	A: Amber G: Green R: Red W: White Y: Yellow	—
Coned				—	—	IPL1-19-*					
ø8		UP	Flush	—	—	IPL1-87-*					
			Extended	—	—	IPL1-88-*					
			Coned	—	—	IPL1-89-*					
ø6		UP	Flush	—	—	IPL1-67-*					
			Extended	—	—	IPL1-68-*					
			Coned	—	—	IPL1-69-*					
Illuminated Pushbutton		ø30	N	Extended	Momentary	1NO-1NC	EB3P-LBAN211-*	A: Amber G: Green R: Red S: Blue W: White Y: Yellow	—		
					Maintained	1NO-1NC	EB3P-LBAON211-*				
	Mushroom			Pushlock Turn Reset	1NO-1NC	EB3P-LBAVN311-R	R				
	ø22	TW	Extended	Momentary	1NO-1NC	EB3P-LBAW211-*	A: Amber G: Green R: Red S: Blue W: White Y: Yellow	—			
				Maintained	1NO-1NC	EB3P-LBAOW211-*					
			Mushroom	Pushlock Turn Reset	1NO-1NC	EB3P-LBAVW411-R			R		
		HW	Round	Momentary	1NO	EB3P-LBH1W110-*	A: Amber G: Green R: Red S: Blue W: White Y: Yellow	—			
				Maintained	1NO	EB3P-LBHA1W110-*					
		LW	Round	Momentary	DPDT	EB3P-LBL1W1C2-*					
	Maintained			DPDT	EB3P-LBLA1W1C2-*						
	Square		Momentary	DPDT	EB3P-LBL2W1C2-*						
	Illuminated Selector Switch (Note 3)	ø30	N	Round	2-position	1NO-1NC			EB3P-LSAN211-*	A: Amber G: Green R: Red S: Blue W: White Y: Yellow	Maintained
					3-position	2NO			EB3P-LSAN320-*		Maintained
ø22		TW	Round	2-position	1NO-1NC	EB3P-LSAW211-*			Maintained		
				2-position, return from right	1NO-1NC	EB3P-LSAW2111-*			Spring return from right		
				3-position	2NO	EB3P-LSAW320-*			Maintained		
				3-position, return from right	2NO	EB3P-LSAW3120-*			Spring return from right		
				3-position, return from left	2NO	EB3P-LSAW3220-*			Ring return from left		
				3-position, 2-way return	2NO	EB3P-LSAW3320-*			2-way spring return		
				HW	Round	2-position	1NO-1NC	EB3P-LSHW211-*	Maintained		
3-position		2NO	EB3P-LSHW320-*			Maintained					
LW		Round	2-position	DPDT	EB3P-LSL1W2C2-*	Maintained					
		Round w/Square Bezel	3-position	DPDT	EB3P-LSL3W3C2-*	Maintained					
Buzzer		ø30	—	—	Continuous sound	—	EB3P-ZUN12C	—	—		
	Intermittent sound				—	EB3P-ZUN12F					

Note 1: Codes N, TW, HW, LW, and UP are the series names of IDEC's control units.

Note 2: Specify a color code in place of *.

Note 3: Illuminated selector switches have a knob operator.

Accessories

Name	Type No.	Package Quantity
LED Lamp	EB9Z-LDS1-*	1

Note: Specify a color code in place of * in the Type No.

A: amber, G: green, R: red, S: blue, W: white, Y: yellow

EB3L Lamp Barrier

Explosion-Protection and Electrical Specifications

Explosion Protection		Intrinsic safety type (IEC compliant) [Exia] II C	
Degree of Protection		IP20 (IEC60529)	
Installation Location	Lamp Barrier	Safe indoor place (non-hazardous area)	
	Pilot Light, Illuminated Switch, Buzzer	For zone 0, 1, 2 hazardous areas	
Non-intrinsically Safe Circuit Maximum Voltage (Um)		250V AC 50/60Hz, 250V DC	
Operation		Input ON, Output ON (1:1)	
Intrinsically Safe Circuits (Output)	Wiring Method	1-channel Separate Wiring	16-channel Common Wiring
	Rated Operating Voltage	12V DC	
	Rated Operating Current	10 mA DC	
	Maximum Output Voltage (Uo)	13.2V DC	
	Maximum Output Current (Io)	14.2 mA	227.2 mA
	Maximum Output Power (Po)	46.9 mW	750 mW
	Maximum External Inductance (Lo) (Note)	125 mH	0.68 mH
	Maximum External Capacitance (Co) (Note)	740 nF	
	Allowable Wiring Resistance (Rw)	200/(n+1) Ω (n = number of common channels)	
	Maximum Channels per Common Line	16	
Voltage and Current when Connecting Control Units		Pilot light: 3.5V, 8.5 mA	Miniature pilot light: 2V, 10 mA
Non-intrinsically Safe Circuits (Signal Input)		Rated voltage: 24V DC Rated current: 5 mA (connector type: 4 mA)	

General Specifications

Power Voltage Type	AC Power Type	DC Power Type
Rated Power Voltage	100 to 240V AC	24V DC
Allowable Voltage Range	85 to 264V AC	21.6 to 26.4V DC
Rated Frequency	50/60 Hz (allowable range: 47 to 63 Hz)	—
Inrush Current	10A (100V AC) 20A (200V AC)	10A
Dielectric Strength (1 minute, 1 mA)	Between intrinsically safe circuit and non-intrinsically safe circuit: 1500V AC Between AC power and signal input: 1500V AC	
Operating Temperature	-20 to +60°C (no freezing)	
Storage Temperature	-20 to +60°C (no freezing)	
Operating Humidity	45 to 85% RH (no condensation)	
Atmosphere	800 to 1100 hPa	
Pollution Degree	2 (IEC60664)	
Insulation Resistance	10 M Ω minimum (500V DC megger, between the same poles as the dielectric strength)	
Vibration Resistance	Damage Limits	Panel mounting: 10 to 55 Hz, amplitude 0.75 mm (2 hours each on X, Y, Z)
		DIN rail mounting: 10 to 55 Hz, amplitude 0.35 mm (2 hours each on X, Y, Z)
Shock Resistance	Damage Limits	Panel mounting: 500 m/s ² (3 times each on X, Y, Z)
		DIN rail mounting: 300 m/s ² (3 times each on X, Y, Z)
Terminal Style	M3 screw terminal	
Mounting	35-mm-wide DIN rail or panel mounting (M4 screw)	
Power Consumption (approx.)	8.8 VA (EB3L-S10SA at 200V AC) 5.2 W (EB3L-S16CSD at 24V DC)	
Weight (approx.)	0.35 kg (EB3L-S16CSD)	

General Specifications of Pilot Light, Illuminated Pushbutton, Illuminated Selector Switch, and Buzzer

Operating Temperature		-20 to +60°C (no freezing)	
Operating Humidity		45 to 85% RH (no condensation)	
Dielectric Strength (1 mA, 1 minute)		EB3P: 1000V AC IPL1: 500V AC (between intrinsically safe circuit and dead parts)	
Insulation Resistance		10 M Ω minimum (500V DC megger, between the same poles as the dielectric strength)	
Pilot Light/Miniature Pilot Light	Degree of Protection	IP65 (IEC60529) (except for terminals) EB3P-LU/IPL1: IP40	
	Lens/Illumination Color	Pilot light: Amber, blue, green, red, white, yellow Miniature pilot light: Amber, green, red, white, yellow	
Intrinsic Safety Ratings and Parameters	Intrinsic Safety Ratings and Parameters	1-channel Separate Wiring Maximum input voltage (Ui): 13.2V Maximum input current (Ii): 14.2 mA Maximum input power (Pi): 46.9 mW Internal inductance (Li): \leq 5 μ H Internal capacitance (Ci): \leq 2 nF	
		16-channel Common Wiring Maximum input voltage (Ui): 13.2V Maximum input current (Ii): 227.2 mA Maximum input power (Pi): 750 mW Internal inductance (Li): \leq 80 μ H Internal capacitance (Ci): \leq 32 nF	
Illuminated Switch	Degree of Protection	IP65 (IEC60529) (except for terminals) EB3P-LSAW*: IP54	
	Illumination Color	Amber, blue, green, red, white, yellow	
	Contact Voltage/Current	12V DC \pm 10%, 10 mA \pm 20% (when connecting to the EB3C)	
	Intrinsic Safety Ratings and Parameters	16-channel Common Wiring Maximum input voltage (Ui): 13.2V Maximum input current (Ii): 227.2 mA Maximum input power (Pi): 750 mW Internal inductance (Li): \leq 80 μ H Internal capacitance (Ci): \leq 32 nF	
Buzzer	Degree of Protection	IP20 (IEC60529) (except for terminals)	
	Sound Volume	75 dB minimum (at 1 m)	
	Sound Source	Piezoelectric oscillator (continuous or intermittent)	
Intrinsic Safety Ratings and Parameters	Intrinsic Safety Ratings and Parameters	1-channel Separate Wiring Maximum input voltage (Ui): 13.2V Maximum input current (Ii): 14.2 mA Maximum input power (Pi): 46.9 mW Internal inductance (Li): \leq 100 mH Internal capacitance (Ci): \leq 260 nF	

Note: Connect buzzers in separate wiring. Buzzers cannot be used in common wiring.

Certification No.

Certification Organization	Type	Explosion Protection	Certification No.
FM	Lamp Barrier	Class I, II, III Div. 1 Group A, B, C, D, E, F, G Class I, Zone 0 AEx [ia] IIC	3019223
	Buzzer	Class I, II, III Div. 1 Group A, B, C, D, E, F, G T6 Class I, Zone0 AExIICT6	
CSA	Lamp Barrier	Class I Div. 1 Group A, B, C, D	166730
	Buzzer	Class I Div. 1 Group A, B, C, D T6	
NEMKO	Lamp Barrier	[EEExia] II C	Nemko 02ATEX279
	Buzzer	Exia IICT6	Nemko 03ATEX1628X
TIIS Japan	Lamp barrier	[Exia] II C	C16355
	Pilot light/miniature pilot light (separate wiring)	Exia II CT6	C16361
	Pilot light/miniature pilot light (common wiring)	Exia II CT4	C16360
	Illuminated switch	Exia II CT4	C16362
ClassNK	Buzzer	Exia II CT6	C16363
	Lamp barrier	Exia II C	02T606
	Buzzer	Exia II CT6	04T605

Note: Illuminated switches, pilot lights, and miniature pilot lights are certified by TIIS Japan and NK Japan only. FM, CSA, and NEMKO regard these units as simple apparatus, and require no certification.

EB3L Lamp Barrier

Internal Circuit Block Diagram

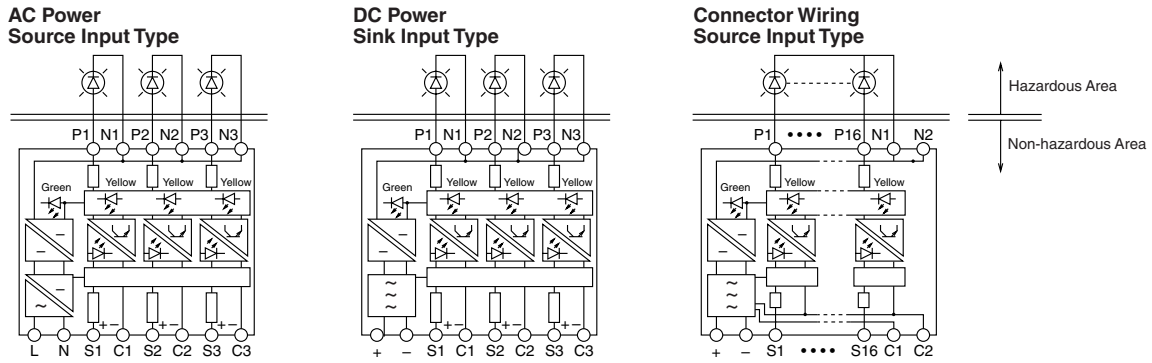

Allowable Inductance/Capacitance for Intrinsically Safe External Wiring

Keep the inductance (L_w) and capacitance (C_w) for the external wiring in the intrinsically safe circuit as shown below:

$$L_w \leq L_o - L_i, C_w \leq C_o - C_i$$

where L_o is the maximum external inductance, L_i is the internal inductance, C_o is the maximum external capacitance, and C_i is the internal capacitance.

Dimensions

• Terminal Type

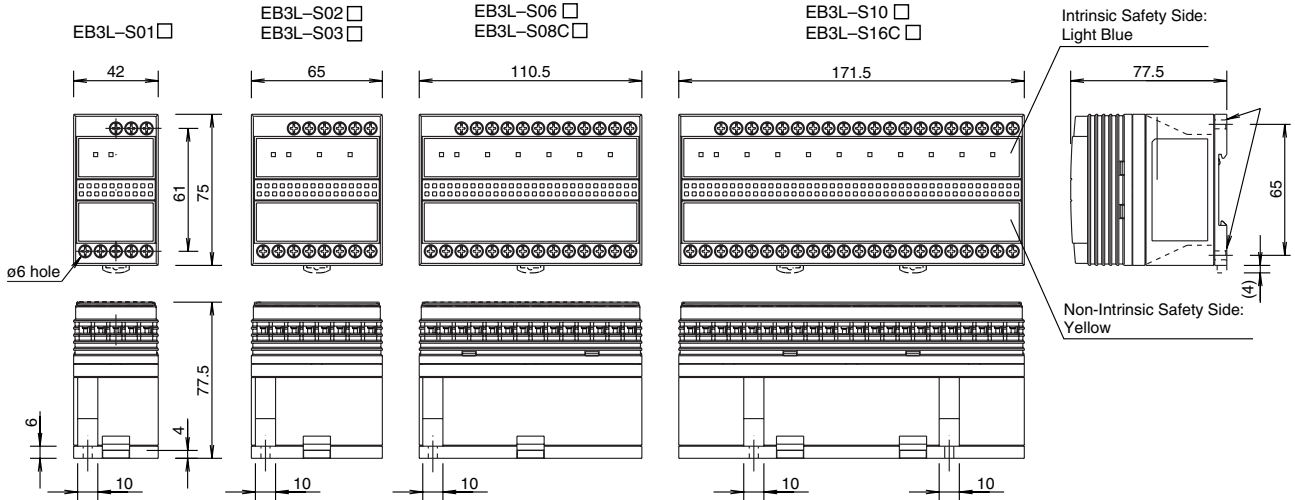

Mounting Hole Layout (Screw Mounting)

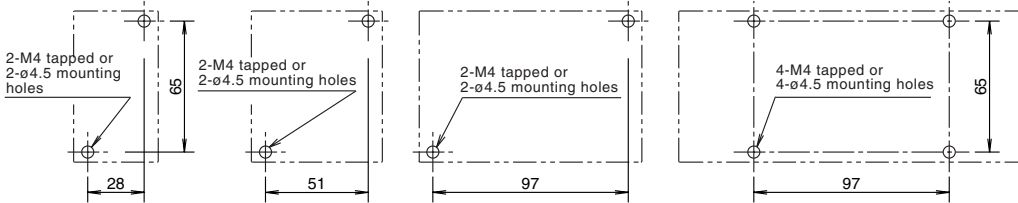

• Connector Type

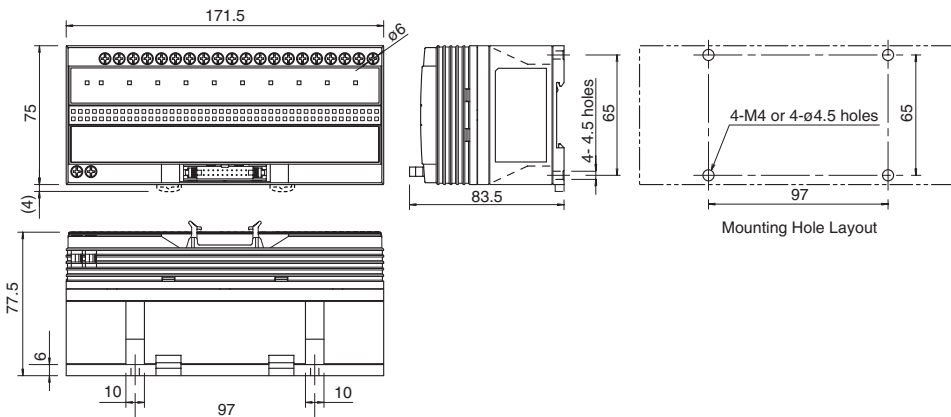

Applicable Crimping Termin

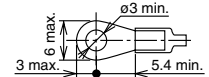

Stripping the Wire End

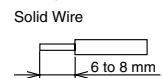

Stranded Wire (Ferrule)

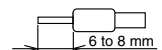

All dimensions in mm.

EB3L Lamp Barrier

• Pilot Lights

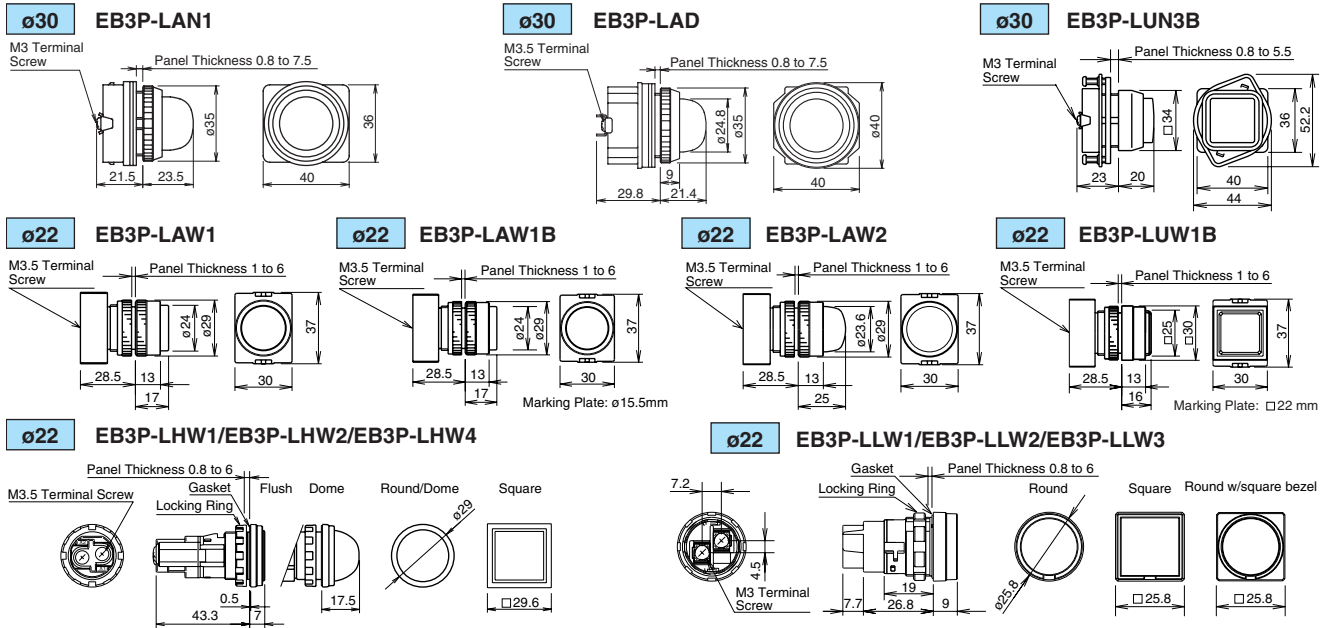

• Miniature Pilot Lights

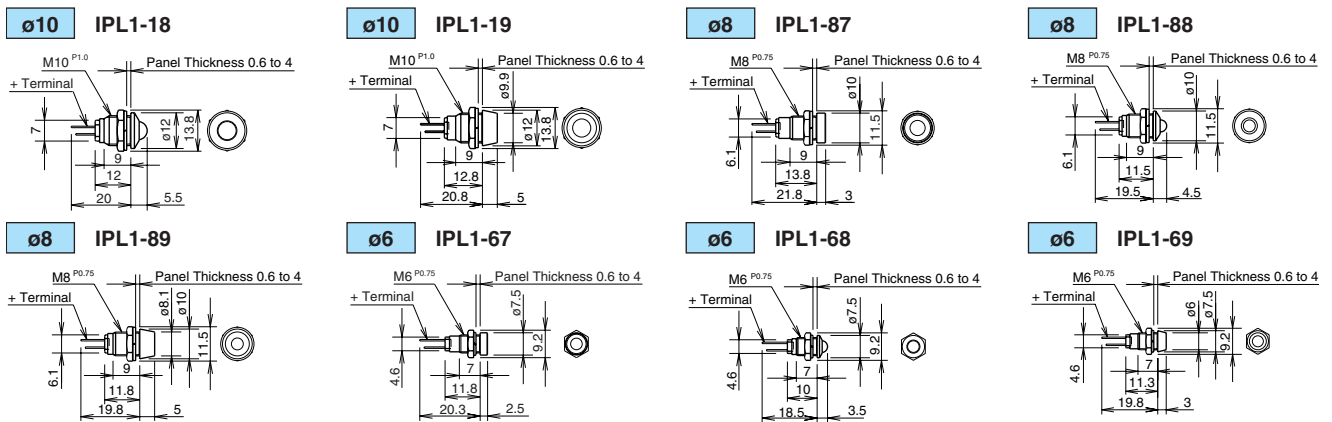

• Illuminated Pushbuttons

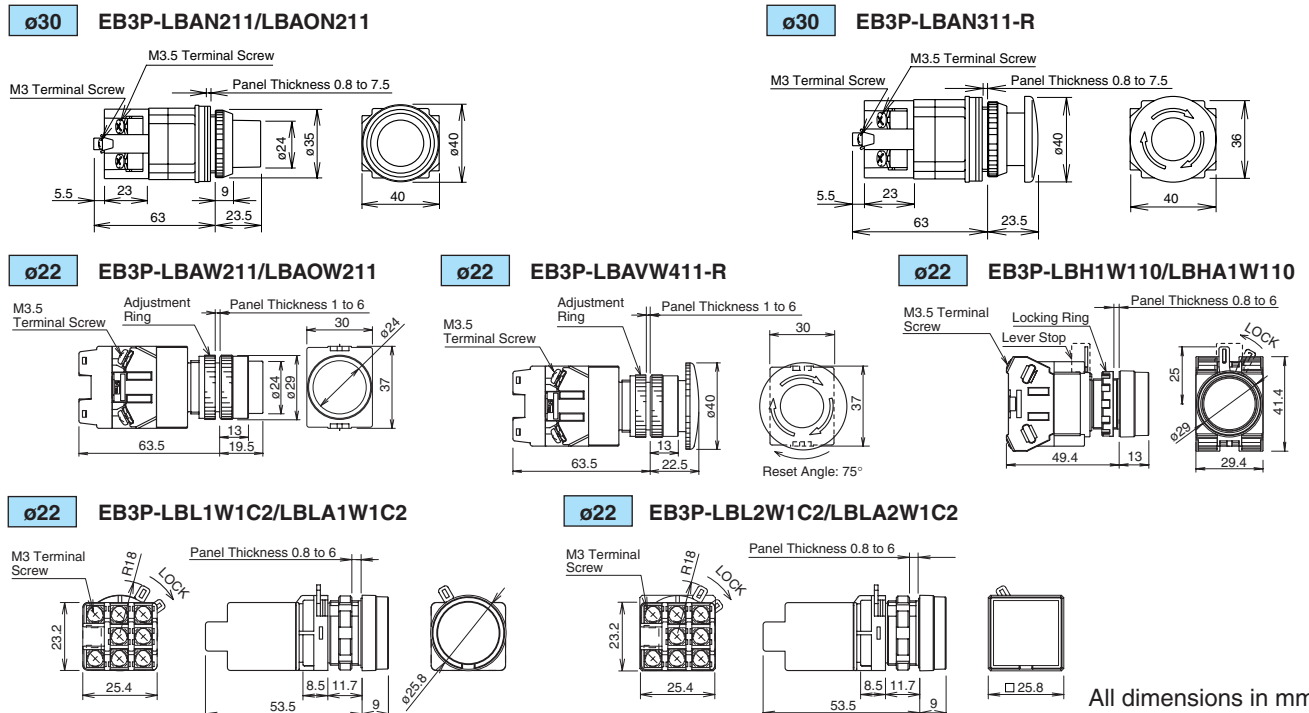

All dimensions in mm.

EB3L Lamp Barrier

• Illuminated Selector Switches

ø30 EB3P-LSAN211/EB3P-LSAN320

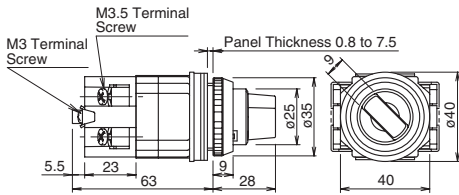

ø22 EB3P-LSHW211/EB3P-LSHW320

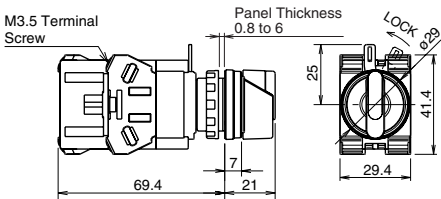

ø22 EB3P-LSAW***

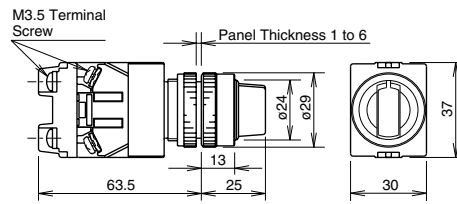

ø22 EB3P-LSL1W2C2/EB3P-LSL3W3C2

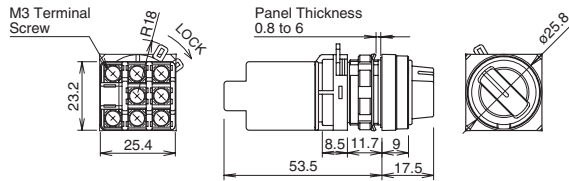

• Buzzer

ø30 EB3P-ZUN12C/ZUN12F

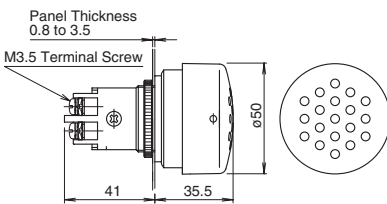

• LED Lamp

EB9Z-LDS1

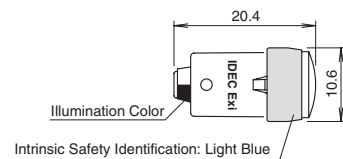

Illumination color is marked on the terminal.

Polarity Identification

• Pilot Lights/Illuminated Pushbuttons/Illuminated Selector Switches

Positive terminal: X1

Negative terminal: X2

• Miniature Pilot Lights

Positive terminal: Long pin terminal

Negative terminal: Short pin terminal

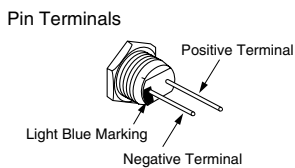

A light blue marking is indicated on the negative terminal side to identify intrinsically safe usage.

• Buzzer

Positive terminal: +

Negative terminal: -

• LED Lamp

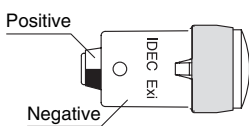

Panel Cut-out

• Pilot Lights/Illuminated Pushbuttons/Illuminated Selector Switches/Buzzers

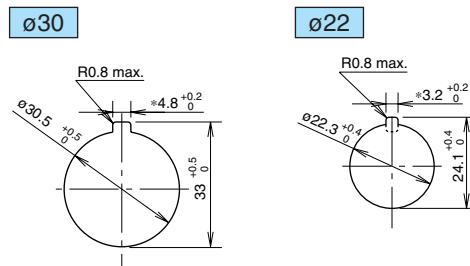

• Miniature Pilot Lights

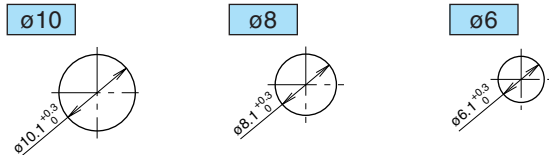

* The 4.8 or 3.2 recess is needed only when using an anti-rotation ring or a nameplate with an anti-rotation projection.

All dimensions in mm.

Non-intrinsically Safe External Input Wiring Examples

• 8-circuit Common Wiring, Source Input Type

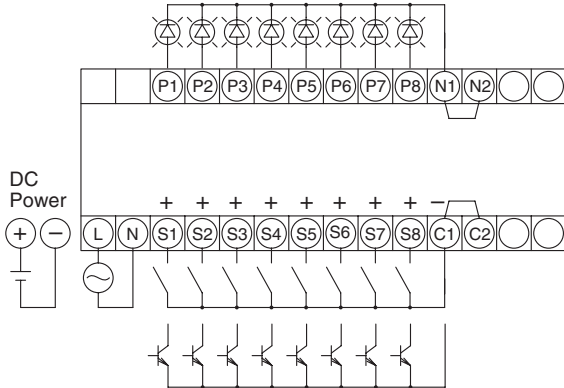

• 6-circuit Sink Input Type

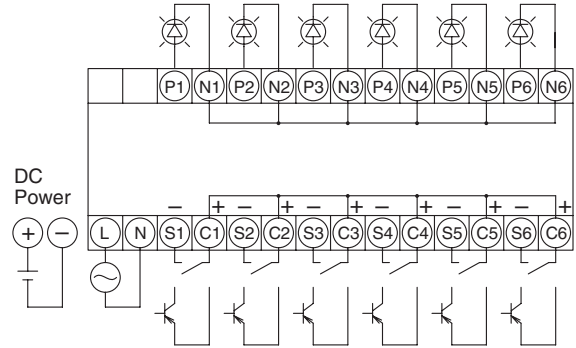

Connector Wiring Type Terminal Arrangement

• EB3L-S16CSD-C

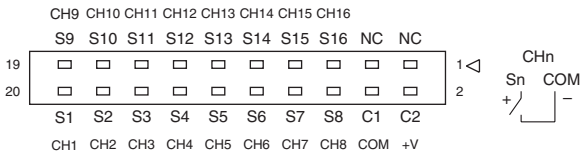

• EB3L-S16CKD-C

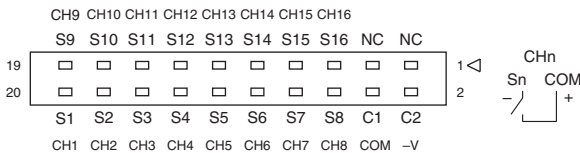

Wiring Example with IDEC's PLC MicroSmart

EB3L-S16CSD-C		FC4A-T16K3		EB3L-S16CKD-C		FC4A-T16S3	
Terminal	Input	Output	Terminal	Terminal	Input	Output	Terminal
20	S1	Q0	20	20	S1	Q0	20
19	S9	Q10	19	19	S9	Q10	19
18	S2	Q1	18	18	S2	Q1	18
17	S10	Q11	17	17	S10	Q11	17
16	S3	Q2	16	16	S3	Q2	16
15	S11	Q12	15	15	S11	Q12	15
14	S4	Q3	14	14	S4	Q3	14
13	S12	Q13	13	13	S12	Q13	13
12	S5	Q4	12	12	S5	Q4	12
11	S13	Q14	11	11	S13	Q14	11
10	S6	Q5	10	10	S6	Q5	10
9	S14	Q15	9	9	S14	Q15	9
8	S7	Q6	8	8	S7	Q6	8
7	S15	Q16	7	7	S15	Q16	7
6	S8	Q7	6	6	S8	Q7	6
5	S16	Q17	5	5	S16	Q17	5
4	COM(-)	COM(-)	4	4	COM(+)	COM(+)	4
3	NC	COM(-)	3	3	NC	COM(+)	3
2	+V	+V	2	2	-V	-V	2
1	NC	+V	1	1	NC	-V	1

Note 1: The wiring in dashed line does not affect the operation of the EB3L lamp barriers.

Note 2: Applicable connector is IDEC's JE1S-201.

EB3L Lamp Barrier

Wiring Example of Intrinsically Safe External Output

1. Common Wiring (Maximum 16 circuits) (Buzzers cannot be wired in a common line.)

- All output lines are wired to a common line inside the intrinsically safe equipment (one common line per intrinsically safe circuit).

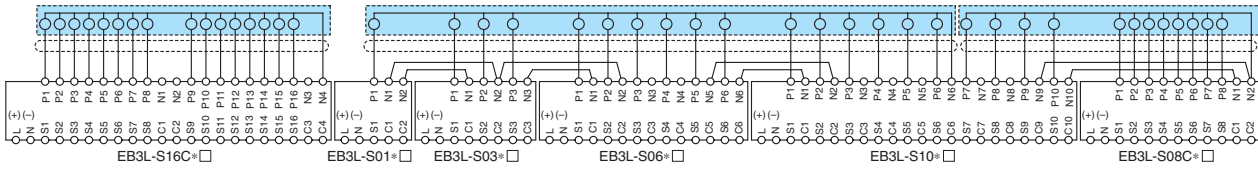

- All input lines are wired to a common line outside the intrinsically safe equipment (one common line per intrinsically safe circuit).

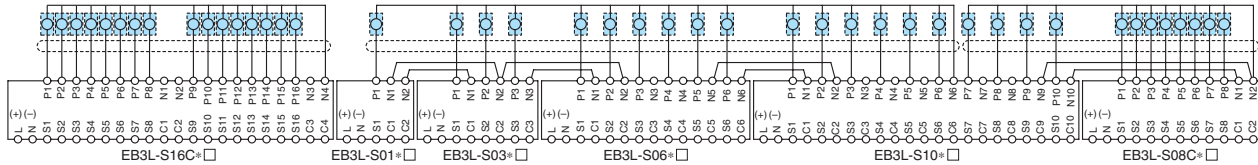

2. Separate Wiring

- Each output line of the EB3L makes up one independent intrinsically safe circuit of a pilot light or buzzer.

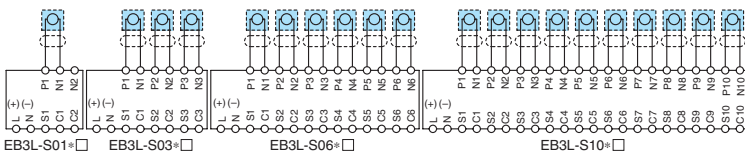

Note:
When using two or more EB3L's to set up one intrinsically safe circuit in the common wiring configuration, interconnect two neutral terminals (N1 through N10) on each EB3L between adjacent EB3L's in parallel.

3. Wiring Illuminated Pushbuttons and Illuminated Selector Switches

(A maximum of 16 channels of EB3L and EB3C can be wired to a common line.)

- The following example illustrates the wiring for a total of 10 contacts used by three illuminated pushbuttons (LB1 to LB3) and three illuminated selector switches (LS1 to LS3).

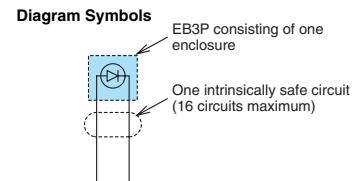
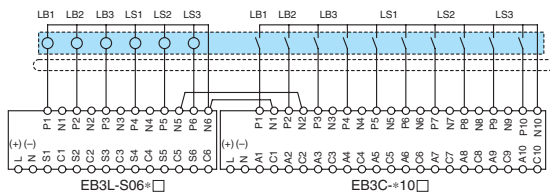

Recommended Connector Cable for Connector Types

Description	No. of Poles	Length (m)	Type No.	Appearance	Applicable Type
I/O Terminal Cable	20	0.5	FC9Z-H050A20		MicroSmart I/O Module
		1	FC9Z-H100A20		
		2	FC9Z-H200A20		
		3	FC9Z-H300A20		
I/O Terminal Cable	20	0.5	FC9Z-H050B20		MicroSmart I/O Module
		1	FC9Z-H100B20		
		2	FC9Z-H200B20		
Cable with Crimping Terminal	20	1	BX9Z-H100E4		Screw Terminal Type
		2	BX9Z-H200E4		
		3	BX9Z-H300E4		
40-pin Cable for PLC	20	1	BX9Z-H100B		Mitsubishi A, Q Series Output Module (sink type) ↓ EB3L-S16CSD-C
		2	BX9Z-H200B		
		3	BX9Z-H300B		

Precautions for Operation

1. Installation of EB3L Lamp Barriers

- (1) The EB3L can be installed in any direction.
- (2) Install the EB3L lamp barrier in a safe area (non-hazardous area) in accordance with intrinsic safety ratings and parameters. To avoid mechanical shocks, install the EB3L in an enclosure which suppresses shocks.
- (3) When installing or wiring the EB3L, prevent electromagnetic and electrostatic inductions in the intrinsically safe circuit. Also prevent the intrinsically safe circuits from contacting with another intrinsically safe circuit and any other circuits.

Maintain at least 50 mm clearance, or provide a metallic separating board between the intrinsically safe circuit and non-intrinsically safe circuit. When providing a metallic separating board, make sure that the board fits closely to the enclosure (top, bottom, and both sides). Allowable clearance between the enclosure and board is 1.5 mm at the maximum.

The clearance of 50 mm between the intrinsically safe circuit and non-intrinsically safe circuit may not be sufficient when a motor circuit or high-voltage circuit is installed nearby. In this case, provide a wider clearance between the circuits referring to 6 (3) "Minimum Parallel Distance between the Intrinsically Safe Circuit and Other Circuits."

- (4) In order to prevent contact between intrinsically safe circuits and non-intrinsically safe circuits, mount EB3L units with terminals arranged in the same direction.

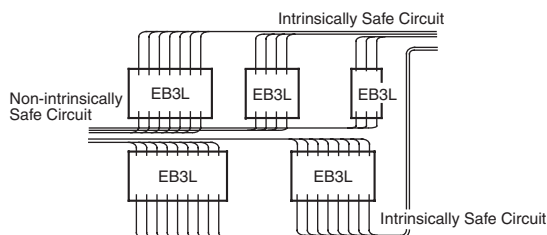

- (5) Maintain at least 6 mm (or 3 mm according to IEC60079-11: 1999) clearance between the terminal of intrinsically safe circuit and the grounded metal part of a metal enclosure, and between the relay terminal block of an intrinsically safe circuit and the grounded metal part of a metal enclosure.
- (6) For installing the EB3L, mount on a 35-mm-wide DIN rail or directly on a panel using screws. The EB3L can be installed in any direction. Make sure to install securely to withstand vibration. When mounting on a DIN rail, push in the clamp completely. Use the BNL5 mounting clips on both sides of the EB3L to prevent from moving sideways.
- (7) Excessive extraneous noise may cause malfunction and damage to the EB3L. When extraneous noise activates the voltage limiting circuit (thyristor), remove the noise source and restore the power.

2. Terminal Wiring

- (1) Using a $\phi 5.5$ mm or smaller screw driver, tighten the terminal screws (including unused terminal screws) to a torque of 0.6 to 1.0 N·m (recommended value).
- (2) Make sure that IP20 is achieved when wiring. Use insulation tubes on bare crimping terminals.
- (3) To prevent disengaged wires from contacting with other intrinsically safe circuits, bind together the wires of one intrinsically circuit.
- (4) When the adjacent terminal is connected to another intrinsically safe circuit, provide an insulation distance of at least 6 mm.

3. Signal Input

- (1) Connect the EB3L to the switches or output equipment which have a low leakage current (0.1 mA maximum).
- (2) The EB3L is equipped with power supply. Do not apply external power to the EB3L.
- (3) When connecting the EB3L's of connector type in parallel, make sure that the same power supply is used. When using C1 and C2 terminals to supply power to outside equipment, maintain the current at 50 mA maximum.

4. Power Voltage

- (1) Do not apply an excessive power voltage, otherwise the EB3L may be damaged.
- (2) The EB3L of AC power type may operate at a low voltage (approx. 20V).

5. Pilot Lights and Buzzers in the Hazardous Area

- (1) EB3P and IPL1 units shown on page 12 can be used with the EB3L.
- (2) Install the EB3P and IPL1 units on enclosures of IP20 or higher protection.
- (3) When wiring, make sure of correct polarities of the EB3P and IPL1.
- (4) Certification mark is supplied with the units. Attach it on the visible area of the EB3P or IPL1 (for Japan application).
- (5) Magnesium content of metallic enclosure must be 6% or less (steel and aluminum are acceptable).
- (6) The maximum exposed area of plastic enclosure is as follows.

IIC: 20 cm² maximum

IIB: 100 cm² maximum

When the enclosure has a wider exposed area, attach a caution label as shown below.

Caution

To prevent electrostatic charges, do not rub the enclosure surface during operation. Use a soft cloth dipped with water for cleaning.

EB3L Lamp Barrier

Precautions for Operation

6. Wiring for Intrinsic Safety

- (1) The voltage applied on the general circuit connected to the non-intrinsically safe circuit terminals of the EB3L lamp barrier must be 250V AC, 50/60Hz, or 250V DC at the maximum under any conditions, including the voltage of the power line and the internal circuit.
- (2) When wiring, take into consideration the prevention of electromagnetic and electrostatic charges on intrinsically safe circuits. Also, prevent intrinsically safe circuits from contacting with other circuits.
- (3) The intrinsically safe circuits must be separated from non-intrinsically safe circuits. Contain intrinsically safe circuits in a metallic tube or duct, or separate the intrinsically safe circuits referring to the table at right.

Note: Cables with a magnetic shield, such as a metallic sheath, prevent electromagnetic induction and electrostatic induction, however, a non-magnetic shield prevents electrostatic induction only. For non-magnetic shields, take a preventive measure against electromagnetic induction.

Finely twisted pair cables prevent electromagnetic induction. Adding shields to the twisted pair cables provides protection against electrostatic induction.

Minimum Parallel Distance between the Intrinsically Safe Circuit and Other Circuits (mm)

Voltage and Current of Other Circuits	Over 100A	100A or less	50A or less	10A or less
Over 440V	2000	2000	2000	2000
440V or less	2000	600	600	600
220V or less	2000	600	600	500
110V or less	2000	600	500	300
60V or less	2000	500	300	150

- (4) When identifying intrinsically safe circuits by color, use light blue terminal blocks and cables.
- (5) When using two or more EB3L's to set up one intrinsically safe circuit in the common wiring configuration, interconnect two neutral terminals (N1 through N10) on each EB3L between adjacent EB3L's in parallel.
- (6) Make sure that the power of the EB3L, pilot lights, and other connected units are turned off before starting inspection or replacement.

Note: For the details of wiring the intrinsically safe circuits, refer to a relevant test guideline for explosion-proof electric equipment in each country.



Safety Precautions

- Do not use the EB3C Relay Barrier and EB3L Lamp Barrier for other than explosion protection purposes.
- Read the user's manual to make sure of correct operation before starting installation, wiring, operation, maintenance, and inspection of the EB3C Relay Barrier and EB3L Lamp Barrier.

Specifications and other descriptions in this catalog are subject to change without notice.



IDEC CORPORATION

7-31, Nishi-Miyahara 1-Chome, Yodogawa-ku, Osaka 532-8550, Japan
 Tel: +81-6-6398-2571, Fax: +81-6-6392-9731
 E-mail: products@idec.co.jp

IDEC CORPORATION (USA)

1175 Elko Drive, Sunnyvale, CA 94089-2209, USA
 Tel: +1-408-747-0550 / (800) 262-IDEC (4332)
 Fax: +1-408-744-9055 / (800) 635-6246
 E-mail: opencontact@idec.com

IDEC CANADA LIMITED

Unit 22-151, Brunel Road Mississauga, Ontario, L4Z 1X3, Canada
 Tel: +1-905-890-8561, Toll Free: (888) 317-4332
 Fax: +1-905-890-8562
 E-mail: sales@ca.idec.com

IDEC AUSTRALIA PTY. LTD.

2/3 Macro Court, Rowville, Victoria 3178, Australia
 Tel: +61-3-9763-3244, Toll Free: 1800-68-4332
 Fax: +61-3-9763-3255
 E-mail: sales@au.idec.com

IDEC ELECTRONICS LIMITED

Unit 2, Beechwood, Chineham Business Park, Basingstoke, Hampshire RG24 8WA, UK
 Tel: +44-1256-321000, Fax: +44-1256-327755
 E-mail: sales@uk.idec.com

IDEC ELEKTROTECHNIK GmbH

Wendenstrasse 331, D-20537 Hamburg, Germany
 Tel: +49-40-25 30 54 10, Fax: +49-40-25 30 54 24
 E-mail: service@idec.de

IDEC (SHANGHAI) CORPORATION

Room 608-609, 6F, Gangtai Plaza, No. 700, Yan'an East Road, Shanghai 200030, P.R.C.
 Tel: +86-21-5353-1000, Fax: +86-21-5353-1263
 E-mail: idec@cn.idec.com

IDEC (SHANGHAI) CORPORATION

Beijing Office
 Unit 1002, No. 10 Kuntai Building, Zhaowai Dajie, Zhao Yang District, Beijing, 100020, P.R.C.
 Tel: +86-10-6599-5541, Fax: +86-10-6599-5540

IDEC (SHENZHEN) CORPORATION

Unit AB-3B2, Tian Xiang Building, Tian'an Shuma Cheng, Fu Tian District, Shenzhen, Guang Dong 518040, P.R.C.
 Tel: +86-755-8356-2977, Fax: +86-755-8356-2944

IDEC IZUMI (H.K.) CO., LTD.

Unit 1505-07, DCH Commercial Centre No. 25, Westlands Road, Quarry Bay, Hong Kong
 Tel: +852-2803-8989, Fax: +852-2565-0171
 E-mail: info@hk.idec.com

IDEC TAIWAN CORPORATION

8F-1, No. 79, Hsin Tai Wu Road, Sec. 1, Hsi-Chih, Taipei County, Taiwan
 Tel: +886-2-2698-3929, Fax: +886-2-2698-3931
 E-mail: service@idectwn.com.tw

IDEC IZUMI ASIA PTE. LTD.

No. 31, Tannery Lane #05-01, Dragon Land Building, Singapore 347788
 Tel: +65-6746-1155, Fax: +65-6844-5995
 E-mail: info@sg.idec.com