

SX5 Series Communication Terminals (General Information)

Compatible with three of the world's major networks: INTERBUS, DeviceNet and LonWorks.

Key features:

- Detachable upper/lower terminal plugs for easy wiring and maintenance
- Finger-safe spring-up screw terminals
- Compact body 75 × 132 × 48 mm
- Mounting on a 35-mm-wide DIN rail or on a panel surface
- Both inputs and outputs are available in sink and source types. Relay outputs are also available.
- The source output is protected against overload.

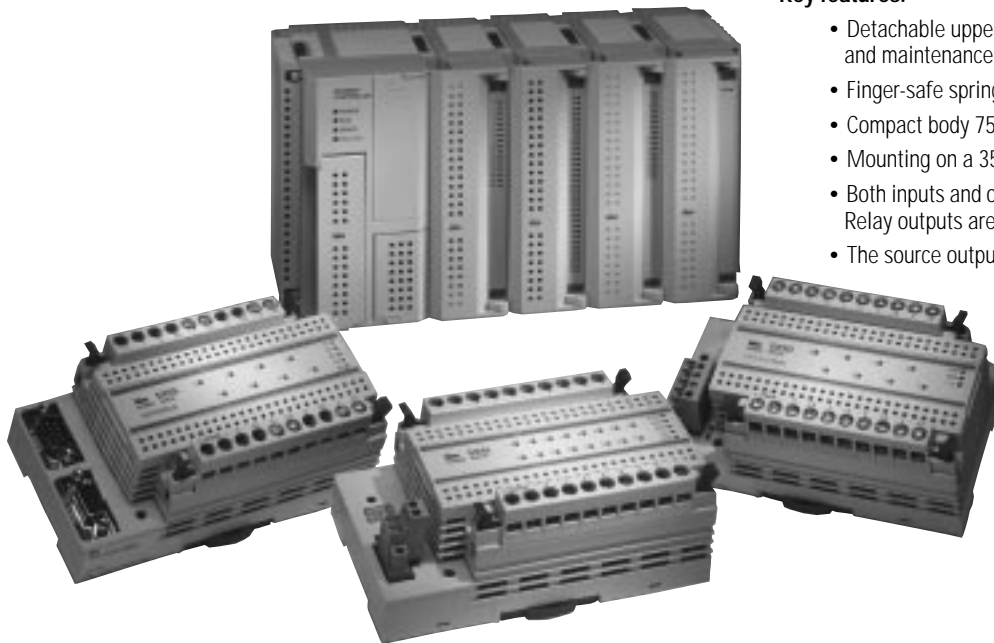

DeviceNet and LonWorks are trademarks of ODVA and Echelon, USA, respectively.

SX5 Communication Terminals

Bus	I/O Type	Specifications	Type No.
INTERBUS	DC Input	16-point source input (24V DC)	SX5S-SBN16S
		16-point sink input (24V DC)	SX5S-SBN16K
	Relay Output	8-point relay output (240V AC/24V DC, 5A)	SX5S-SBR08
	Transistor Output	16-point transistor sink output (24V DC, 0.5A/point, 6.0A/common)	SX5S-SBT16K
		16-point transistor protect source output (24V DC, 0.5A/point, 6.0A/common)	SX5S-SBT16P
	DC input Transistor Output	8-point source input (24V DC) 8-point transistor sink output (24V DC, 0.5A/point, 4.0A/common)	SX5S-SBM16K
8-point sink input (24V DC) 8-point transistor protect source output (24V DC, 0.5A/point, 4.0A/common)		SX5S-SBM16P	
DeviceNet	DC Input	16-point source input (24V DC)	SX5D-SBN16S
		16-point sink input (24V DC)	SX5D-SBN16K
	Relay Output	8-point relay output (240V AC/24V DC, 5A)	SX5D-SBR08
	Transistor Output	16-point transistor sink output (24V DC, 0.5A/point, 6.0A/common)	SX5D-SBT16K
		16-point transistor protect source output (24V DC, 0.5A/point, 6.0A/common)	SX5D-SBT16P
	DC Input Transistor Output	8-point source input (24V DC) 8-point transistor sink output (24V DC, 0.5A/point, 4.0A/common)	SX5D-SBM16K
8-point sink input (24V DC) 8-point transistor protect source output (24V DC, 0.5A/point, 4.0A/common)		SX5D-SBM16P	
LONWORKS	DC Input	16-point source input (24V DC)	SX5L-SBN16S
		16-point sink input (24V DC)	SX5L-SBN16K
	Relay Output	8-point relay output (240V AC/24V DC, 5A)	SX5L-SBR08
	Transistor Output	16-point transistor sink output (24V DC, 0.5A/point, 6.0A/common)	SX5L-SBT16K
		16-point transistor protect source output (24V DC, 0.5A/point, 6.0A/common)	SX5L-SBT16P
	DC Input Transistor Output	8-point source input (24V DC) 8-point transistor sink output (24V DC, 0.5A/point, 4.0A/common)	SX5L-SBM16K
8-point sink input (24V DC) 8-point transistor protect source output (24V DC, 0.5A/point, 4.0A/common)		SX5L-SBM16P	



Options (For INTERBUS, DeviceNet, and LONWORKS)

Name		Type No.	Remarks
Terminal Plug 1		SX9Z-SS1	Upper terminal plug for SX5*-SBN16*, -SBT16*, -SBM16*
Terminal Plug 2		SX9Z-SS2	Lower terminal plug for SX5*-SBN16*, SBT16*
Terminal Plug 3		SX9Z-SS3	Lower terminal plug for SX5*-SBM16*
Terminal Plug 4		SX9Z-SS4	Upper terminal plug for SX5*-SBR08
Terminal Plug 5		SX9Z-SS5	Lower terminal plug for SX5*-SBR08
DIN Rail	Steel (1m)	BNDN1000	1 meter long stell DIN rail
Mounting Clip		BNL5	10 pieces/pack

• One upper and one lower terminal plugs are supplied with every SX5 communication terminal.

• Option (For DeviceNet)

Name		Type No.	Remarks
SX5D Network Connector		SX9Z-CN5G2	Mounting screws are attached

• One network connector and connector mounting screws are supplied with every SX5D communication terminal.

• Option (For LONWORKS)

Name		Type No.	Remarks
SX5L Network Connector		SX9Z-CN22	Mounting screws are attached

• One network connector is supplied with every SX5L communication terminal.

General Specifications

Rated Power Voltage		24V DC
Allowable Voltage Range		19 to 30V DC (including ripple)
Isolation	I/O – Control Circuit	Not isolated
	Control Circuit – Comm. Interface	INTERBUS, DeviceNet, Photocoupler LonWORKS: Transformer coupling
Insulation Resistance		Between live and dead parts: 100 MΩ minimum (500V DC megger)
Dielectric Strength		Between live and dead parts: 1000V AC, 1 minute Between relay outputs and other live parts: 2000V AC, 1 minute
Vibration Resistance	Damage Limits	Amplitude: 0.35 mm, 10 to 55 Hz
	Operating Extremes (relay output)	Amplitude: 0.35 mm, 10 to 55 Hz (contact opening ≤ 1 msec when energized)
Shock Resistance	Damage Limits	294 m/sec ² , 11 m/sec, sine half-wave pulse
	Operating Extremes (relay output)	59 m/sec ² (in the direction of relay contact movement) 98 m/sec ² (in other 5 directions)
Operating Temperature		0 to +55°C (no freezing)
Operating Humidity		30 to 90% RH (no condensation)
Storage Temperature		-20 to +75°C
Storage Humidity		30 to 90% RH
Mounting		Snap-on mount on 35-mm DIN rail Panel-mount with M4 screws
Weight (approx.)		280g

I/O Terminals

Terminal Style	Detachable terminal plug
Rated Insulation Voltage	250V
Terminal Screw	M3 (center to center: 7.62 mm)
Number of Poles	10
Rated Operating Current	7A
Damage Limits	100 insertion/removal cycles
Finger Protection	Yes

Network Status Indicators

• INTERBUS

Indicator	Status	Description
UL	Green ON	Power ON
RC	Green ON	Remote-in cable connected correctly
BA	Green Flash	Ready for transmitting data
	ON	Transmitting data
ER	Red ON	Module error (available on protect output module only; protection is reset when overload is removed)
RD	Red ON	Remote-out cable disabled or network error

• DeviceNet

Indicator	Status	Description
POW	— OFF	Power OFF
	Green ON	Power ON
MNS	— OFF	Power OFF or Dup_MAC_ID test not completed
	Green Flash	Normal operation (not communicating with master)
	ON	Normal operation (communicating with master)
	Red Flash	Minor fault (e.g. timeout)
IO	ON	Critical fault (e.g. duplicate MAC ID)
	— OFF	I/O power OFF
	Green ON	Normal operation
IO	Red ON	Fault (output protection activated) *

* Available on SX5D-SBT16P and SX5D-SBM16P only

• LonWorks

Indicator	Status	Description
POW	Green ON	Power ON
RUN	Green ON	Normal operation
ERR	Red ON	Communication error
I/O	Red ON	I/O communication error
	ON	Application program not configured
SER	Yellow Flash	Network management not configured

SX5 Series Communication Terminals (General Information)

Wiring SX5D and SX5L Cable Connector

- For wiring the communication cable connector on the SX5D and SX5L, use a cable of AWG24 to AWG14 (0.2 to 2.5 mm²). Strip the cable 7 mm from the end as shown below. Each communication terminal can accommodate up to two cables.

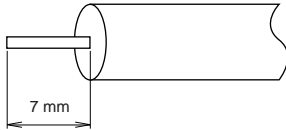

- When connecting two cables to one terminal, use cables of AWG40 to AWG16 (0.2 to 1.5 mm²).
- Do not solder the joint between the cables.
- Tighten terminal screws on the communication cable connector.

Insertion pin positions

When purchasing terminal plugs separately, set the insertion pins as shown below.

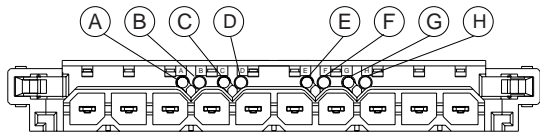

SX5 Type No.	Terminal Plug	Type No.	Pin Positions
SX5*-SBN16*	Upper	SX9Z-SS1	B D F H
	Lower	SX9Z-SS2	A C E G
SX5*-SBR08	Upper	SX9Z-SS4	B D E G
	Lower	SX9Z-SS5	A C F H
SX5*-SBT16*	Upper	SX9Z-SS1	B C E G
	Lower	SX9Z-SS2	A D F H
SX5*-SBM16*	Upper	SX9Z-SS1	B C F H
	Lower	SX9Z-SS3	A D E G

Safety Precautions

- Turn power off to the SX5 communication terminals before starting installation, removal, wiring, maintenance, and inspection of the SX5. Failure to turn power off may cause electrical shocks or fire hazard.
- Wire the SX5 correctly. Improper wiring may cause malfunction, abnormal heat, and fire hazard.
- Use wires of a proper size to meet voltage and current requirements of the SX5. Tighten the terminal screws to a proper tightening torque. A loose screw may cause abnormal heat and fire hazard. Check periodically to see if the screws are tightened securely.

Terminal Symbols

- SX5*-SBR08 → + - 0 C0 1 C1 2 C2 3 C3
- SX5*-SBM16* → + - 0 1 2 3 4 5 6 7
- SX5*-SBN16*/SBT16* → + - 0 1 2 3 4 5 6 7

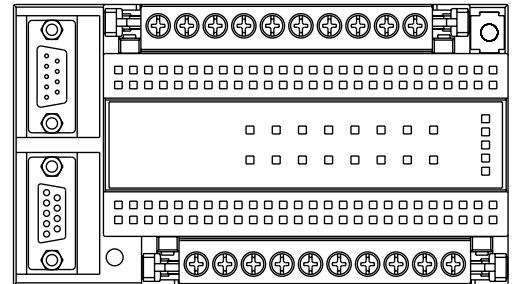

- SX5*-SBN16*/SBT16* → POWER 8 9 10 11 12 13 14 15
- SX5*-SBM16* → POWER 0 1 2 3 4 5 6 7
- SX5*-SBR08 → POWER 4 C4 5 C5 6 C6 7 C7

Dimensions

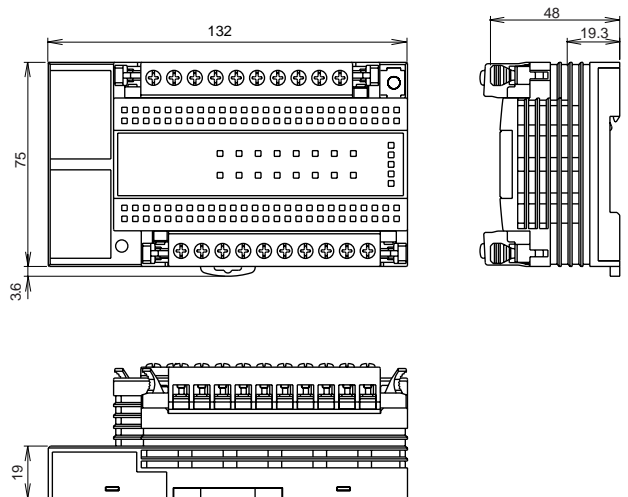

Mounting Hole Layout (Top view)

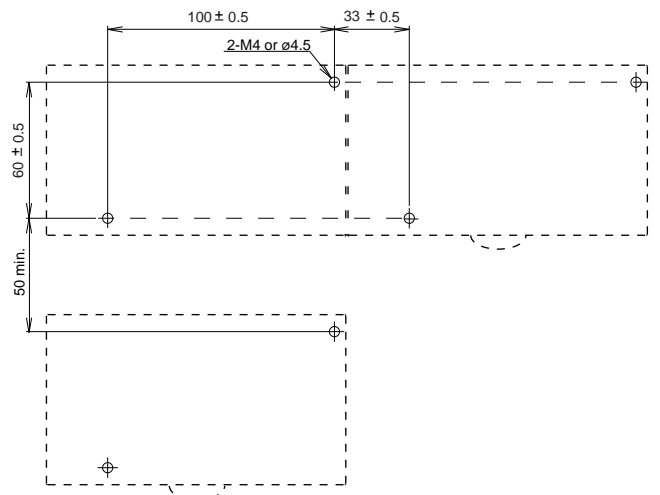

Input/Output Requirements

- When connecting DC two-wire sensors to the SX5, the sensors must meet the following specifications.
 Operating voltage: 12 to 24V DC
 Leakage current: 1 mA maximum
 Residual voltage: 6V maximum
 ON output current: 5.5 mA minimum (at 24V DC)
 The sensor must have an ON output current of 3.5 mA at the minimum. If the sensor does not meet this lower limit, connect a bleeder resistor as shown below. But if the residual voltage is 6V or less, the sensor can still be used although the ON output may be less than 3.5 mA.

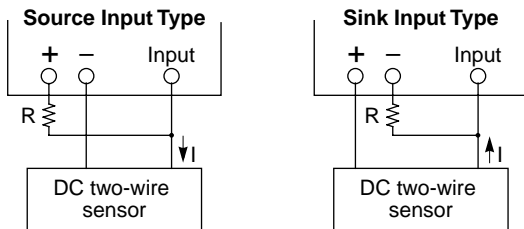

- Use the following formula for calculating the bleeder resistance if needed.

$$R \text{ (k}\Omega\text{)} = \frac{V_{cc} - 6}{I - 3.5}$$

V_{cc}: Power voltage
 I: Lower limit of DC two-wire sensor ON output (mA)
- Do not apply a DC power voltage to the output circuit without connecting a load, otherwise internal elements will be damaged (except for the protect source output type).
- When an overload or short circuit occurs, the protect source output shuts down the output immediately to protect the internal elements from permanent damage. When the cause of the overload or short circuit is removed, the SX5 will restore normal operation automatically.
- When the capacity of mains power supply is small, the overcurrent protection of the mains supply may reduce power supply to the SX5, then the SX5 will stop operation, causing a network error.
- When using the relay output in environments where extraneous noises exist or inductive loads are switched frequently, generating high reverse emf, connect contact protection elements to the output terminals and across the load as shown below.

Varistor System

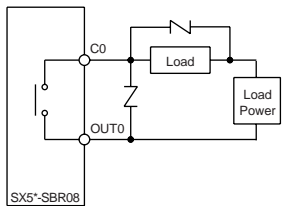

• For both AC and DC power voltages

Diode and Zener Diode System

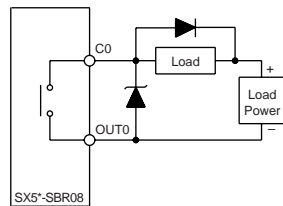

• For DC power voltage only

Operating Instructions

Installation and Wiring (All SX5 Modules)

- Turn power off to the SX5 before installing or removing the connector or the detachable terminal plug.
- Tighten the terminal screws to a torque of 0.6 to 1.0 N-m (6.1 to 10.2 kgf-cm).
- When mounting the SX5 on a panel, tighten the mounting screws to a torque of 1.0 to 1.3 N-m (10.2 to 13.3 kgf-cm). Recommended mounting screw: M4
- When mounting the SX5 on a 35-mm-wide DIN rail, put the SX5 on the DIN rail and press the SX5 towards the rail to lock. To remove, pull out the latch from the bottom of the module using a screwdriver and release the SX5. To re-attach, push back the latch into place and snap on the SX5 again.
- The upper-right mounting hole has a FG terminal. Connect the FG terminal and control box as shown in Figure A, B, or C below. Use a wire of 4 mm² at the minimum to connect the relay terminal block with the safety ground. When mounting on a 35-mm-wide DIN rail, a steel DIN rail is recommended for easy grounding.

Mounting on Steel DIN Rail (Recommended)

- A metal grounding clip is provided on the back of the SX5 to contact with a DIN rail. When mounting the SX5 on a steel DIN rail, the metal grounding clip comes in electrical contact with the DIN rail. Connect the DIN rail to a proper ground.

Mounting on Aluminum DIN Rail

- The upper-right mounting hole has a FG terminal. When mounting the SX5 on an aluminum DIN rail, connect the FG terminal to the panel using the attached M4 screw and nut, and connect the panel to a proper ground as shown in Figure A above.

Panel Mounting

- When mounting the SX5 on a panel surface, attach a crimping terminal of a grounding wire to the FG terminal on the upper-right mounting hole of the SX5, and insert a screw through the mounting hole. Connect the grounding wire to the panel and connect the panel to a proper ground as shown in Figure C above.
- Note:** For secure electrical connection, remove coating from the grounding area on the panel.
- The SX5 uses detachable terminal plugs. To remove and attach the terminal plug, follow the procedures below.
- To remove the terminal plug, squeeze both latches on top of the plug inward to unlock the plug from the socket.
- To reattach the terminal plug, place the plug in the socket with the latches opened and press the plug until it bottoms in the socket, then the latches snap outward to lock the terminal plug.
- Insertion pins are positioned on the base of the terminal plug and inside the socket to prevent insertion of invalid plugs into the socket. The pins are keyed to make sure of correct matching of plug and socket, and prevent swapping of upper and lower plugs.
- When the plug does not fit into the socket properly, check to see if the pin positions on the plug agree with the pin-slot arrangement in the socket. If the pins and the pin slots are in matching positions, check for any chips and obstacles in the socket.
- When cutting cables or wires, keep the SX5 away to prevent ingress of wire chips and fragments.
- When wiring the screw terminals using crimping terminals, use crimping terminals of the dimensions shown below. Each screw terminal can accommodate up to two crimping terminals.]

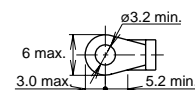

- Note:** Y-shaped crimping terminals can also be used.

J

16 Point Transistor Input Modules (INTERBUS)



Key features include:

- Communicate with Interbus network
- Low cost 16 point input modules (sink/source)
- Easy and convenient detachable upper/lower terminal plugs

Input Type	Source	Sink
Part Number	SX5S-SBN16S	SX5S-SBN16K

DC Input Type

Type No.	SX5S-SBN16S	SX5S-SBN16K
Input Type	DC source input	DC sink input
Input Logic	Active low	Active high
Input Points	16 points	
Input Type	No-voltage input (2-wire DC sensor, 3-wire NPN sensor, no-voltage contact)	No-voltage input (2-wire DC sensor, 3-wire PNP sensor, no-voltage contact)
Rated Input Voltage	24V DC	
Input Voltage Range	0 to the power voltage	
Turn ON Voltage	6V maximum	10V minimum
Turn OFF Voltage	10V minimum	6V maximum
Input Current	7 mA/24V DC	6 mA/24V DC
Common	1 common	
Current Draw	190 mA	170 mA

Terminal Arrangement

Upper Terminal Plug (SX9Z-SS1)		Lower Terminal Plug (SX9Z-SS2)	
Symbol	Signal	Symbol	Signal
+	COM (+)	+	POWER (+)
-	COM (-)	-	POWER (-)
0	IN0	8	IN8
1	IN1	9	IN9
2	IN2	10	IN10
3	IN3	11	IN11
4	IN4	12	IN12
5	IN5	13	IN13
6	IN6	14	IN14
7	IN7	15	IN15

J

Communication Cables

Bus	Network I/F Connector (on the module)	Cable
INTERBUS	9-pin D-sub connector Remote-in: Male Remote-out: Female	INTERBUS cable

Communication Speed and Distance

Bus	Baud Rate	Transmission Distance
INTERBUS	500 kbps	400m (between slaves) 12.8 km (total length)

Communication Configuration

Type No.	ID Code	Station Type	Data Length	Data Address				
SX5S-SBN16S SX5S-SBN16K	02hex	Remote Bus Station with Digital Inputs	1 word (16 inputs)	<table border="1" style="margin-left: auto; margin-right: auto;"> <tr> <td style="text-align: center;">Byte 1</td> <td style="text-align: center;">Byte 0</td> </tr> <tr> <td style="text-align: center;">7 0</td> <td style="text-align: center;">15 8</td> </tr> </table>	Byte 1	Byte 0	7 0	15 8
Byte 1	Byte 0							
7 0	15 8							

Wiring INTERBUS Cable

- Do not install the INTERBUS cable in parallel with or close to motor lines. Keep the INTERBUS cable away from noise sources.
- Turn power off before wiring the INTERBUS cable. Make sure of correct wiring before turning power on.
- Use a special INTERBUS cable and connect the cable as shown below. Use D-sub connectors made of metal or made of plastic with metallic plating. Connect the cable shield with the connector housing electrically.
- INTERBUS Cable Connector Pinouts

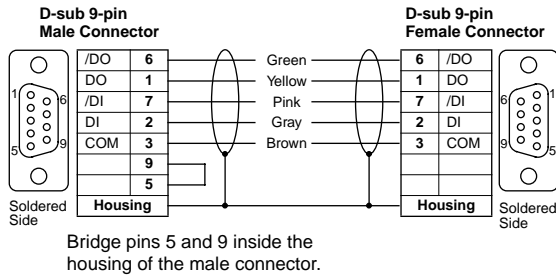

- Stripping and Clamping Cable Ends

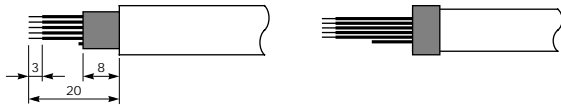

First, strip the cable sheath 20 mm from both ends of the cable and shorten the braided screen by 12 mm.

Bare the core ends 3 mm.

Next, place the braided screen evenly around the cable sheath.

Clamp the shield under the cable grip in the connector housing for conductive connection with the housing.

- Leave open the remote out connector at the last station in the network.
- Supply power to each slave station or to each group of stations separately.
- Master and slave stations may be powered up in any order. But, if a slave station is not powered up while the master is in preparation for transmission, a network error will result.
- Causes of network errors include disconnection or short-circuit of the network cable, strong external noise, invalid command sent to the master station, momentary power voltage drop below the minimum power voltage, faulty transmission line, incorrect cable, and transmission longer than the rated distance.
- When a network error occurs, all outputs are turned off.
- For further information on INTERBUS, read documents published by the INTERBUS CLUB.

16 Point Source Input

SX5S-SBN16S

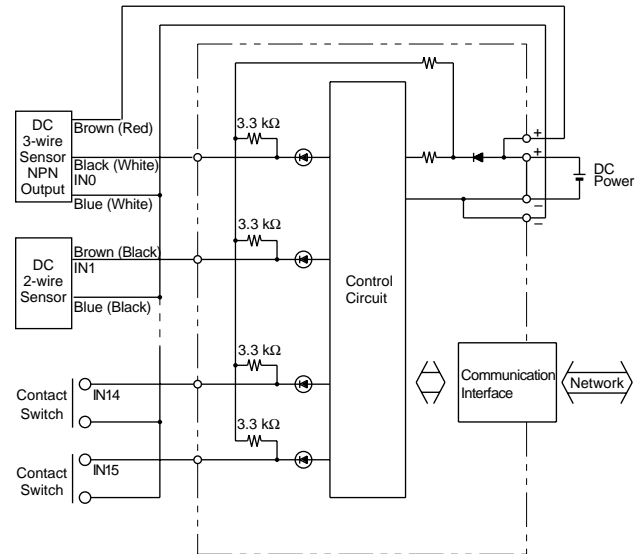

16 Point Sink Input

SX5S-SBN16K

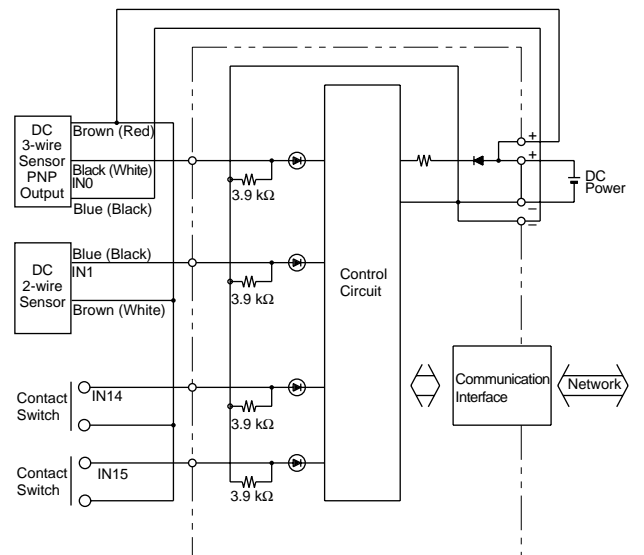

8 Point Relay Output Module (INTERBUS)



Key features include:

- Communicate with Interbus network
- Low cost 8 point relay output module
- Easy and convenient detachable upper/lower terminal plugs
- handles current up to 5A per point

Input Type	Relay Output
Part Number	SX5S-SBR08

Relay Output Type

Type No.	SX5S-SBR08
Output Type	Relay output
Output Points	8 points
Output Type	1NO relay contact
Rated Load Voltage	250V AC, 24V DC
Maximum Load Current	5A/point
Commons/Current	8 commons/5A
Current Draw	120 mA
Built-in Relay	PCB mount, not replaceable

Rated Relay Contact

Maximum Applicable Voltage	250V AC, 125V DC	
Maximum Current	5A	
Rated Load (resistive load)	250V AC/5A, 24V DC/5A	
Minimum Applicable Load	1V DC / 1mA	
Life	Mechanical	20,000,000 operations minimum (18,000 operations/ hour)
	Electrical	See Electrical Life Curve on next page (1,800 operations/ hour)

Communication Cables

Bus	Network I/F Connector (on the module)	Cable
INTERBUS	9-pin D-sub connector Remote-in: Male Remote-out: Female	INTERBUS cable

Terminal Arrangement

Upper Terminal Plug (SX9Z-SS4)		Lower Terminal Plug (SX9Z-SS2)	
Symbol	Signal	Symbol	Signal
+	COM (+)	+	POWER (+)
-	COM (-)	-	POWER (-)
0	OUT0	4	OUT4
C0	COM0	C4	COM4
1	OUT1	5	OUT5
C1	COM1	C5	COM5
2	OUT2	6	OUT6
C2	COM2	C6	COM6
3	OUT3	7	OUT7
C3	COM3	C7	COM7

Communication Speed and Distance

Bus	Baud Rate	Transmission Distance
INTERBUS	500 kbps	400m (between slaves) 12.8 km (total length)

Communication Configuration

Type No.	ID Code	Station Type	Data Length	Data Address										
SX5S-SBR08	01hex	Remote Bus Station with Digital Outputs	1 word (8 outputs)	Byte 1 <table border="1" style="display: inline-table; vertical-align: middle;"> <tr> <td>7</td> <td>.</td> <td>.</td> <td>.</td> <td>.</td> <td>.</td> <td>.</td> <td>.</td> <td>0</td> <td>None</td> </tr> </table>	7	0	None
7	0	None					

Wiring INTERBUS Cable

- Do not install the INTERBUS cable in parallel with or close to motor lines. Keep the INTERBUS cable away from noise sources.
- Turn power off before wiring the INTERBUS cable. Make sure of correct wiring before turning power on.
- Use a special INTERBUS cable and connect the cable as shown below. Use D-sub connectors made of metal or made of plastic with metallic plating. Connect the cable shield with the connector housing electrically.
- INTERBUS Cable Connector Pinouts

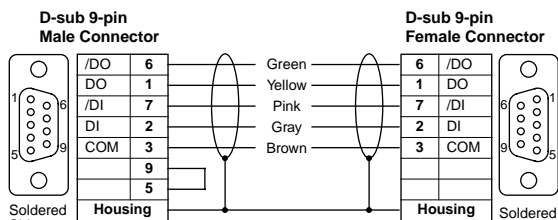

Bridge pins 5 and 9 inside the housing of the male connector.

- Stripping and Clamping Cable Ends

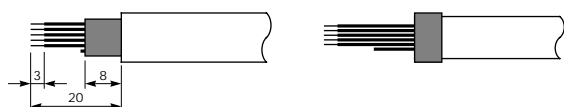

First, strip the cable sheath 20 mm from both ends of the cable and shorten the braided screen by 12 mm. Bare the core ends 3 mm.

Next, place the braided screen evenly around the cable sheath. Clamp the shield under the cable grip in the connector housing for conductive connection with the housing.

- Leave open the remote out connector at the last station in the network.
- Supply power to each slave station or to each group of stations separately.
- Master and slave stations may be powered up in any order. But, if a slave station is not powered up while the master is in preparation for transmission, a network error will result.
- Causes of network errors include disconnection or short-circuit of the network cable, strong external noise, invalid command sent to the master station, momentary power voltage drop below the minimum power voltage, faulty transmission line, incorrect cable, and transmission longer than the rated distance.
- When a network error occurs, all outputs are turned off.
- For further information on INTERBUS, read documents published by the INTERBUS CLUB.

8 Point Relay Output

SX5S-SBR08

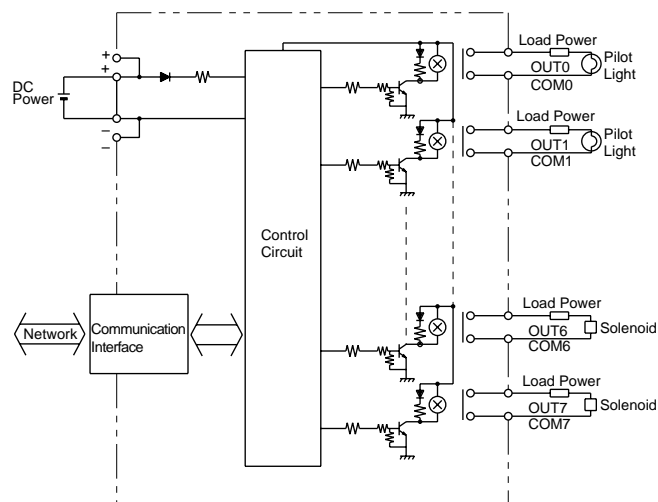

Reference Data

- **◆ Electrical Life Curve:** Relay in SX5S-SBR08
- **Note 1:** AC/DC Resistive Load
- Operating frequency: 1800 operations/hour

AC Load

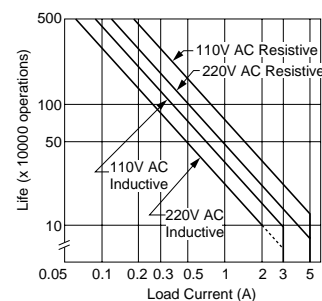

DC Load

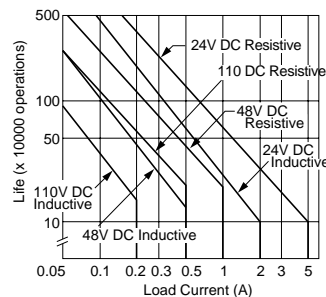

Duty ratio: 40%

- **Note 2:** AC Inductive Load

Line	Making Current	Breaking Current	Frequency	Duty Ratio
Solid	10 I, $\cos \theta = 0.7$	I, $\cos \theta = 0.3$ to 0.4	1800 operations/h	40%
Dashed	5 I, $\cos \theta = 0.7$	I, $\cos \theta = 0.3$ to 0.4	300 operations/h	

- **Note 3:** DC Inductive Load

Operating frequency: 1800 operations/hour
Duty ratio: 40%
Time constant: L/R = 15 msec

16 Point Transistor Output Modules (INTERBUS)

Key features include:

- Communicate with Interbus network
- Low cost 16 point transistor output modules (sink/source)
- Easy and convenient detachable upper/lower terminal plugs
- The source output is protected against overload

Input Type	Source	Sink
Part Number	SX5S-SBT16K	SX5S-SBT16P

Transistor Output Type

Type No.	SX5S-SBT16K	SX5S-SBT16P
Output Type	Sink output	Protect source output
Output Points	16 points	
Output Type	N-channel MOS open drain	P-channel MOS open drain
Rated Load Voltage	24V DC	
Load Voltage Range	3 to 30V DC	19 to 30V DC
Maximum Load Current	0.5A/point	
Commons/Current	1 common/6A	
Short-circuit Protection	No	Yes
Current Draw	70 mA	100 mA

Terminal Arrangement

Upper Terminal Plug (SX9Z-SS1)		Lower Terminal Plug (SX9Z-SS2)	
Symbol	Signal	Symbol	Signal
+	COM (+)	+	POWER (+)
-	COM (-)	-	POWER (-)
0	OUT0	8	OUT8
1	OUT1	9	OUT9
2	OUT2	10	OUT10
3	OUT3	11	OUT11
4	OUT4	12	OUT12
5	OUT5	13	OUT13
6	OUT6	14	OUT14
7	OUT7	15	OUT15

J

Communication Cables

Bus	Network I/F Connector (on the module)	Cable
INTERBUS	9-pin D-sub connector Remote-in: Male Remote-out: Female	INTERBUS cable

Communication Speed and Distance

Bus	Baud Rate	Transmission Distance
INTERBUS	500 kbps	400m (between slaves) 12.8 km (total length)

Communication Configuration

Type No.	ID Code	Station Type	Data Length	Data Address				
SX5S-SBT16K SX5S-SBT16P	01hex	Remote Bus Station with Digital Outputs	1 word (16 outputs)	<table style="width: 100%; border-collapse: collapse;"> <tr> <td style="text-align: center;">Byte 1</td> <td style="text-align: center;">Byte 0</td> </tr> <tr> <td style="text-align: center;">7 0</td> <td style="text-align: center;">15 8</td> </tr> </table>	Byte 1	Byte 0	7 0	15 8
Byte 1	Byte 0							
7 0	15 8							

Wiring INTERBUS Cable

- Do not install the INTERBUS cable in parallel with or close to motor lines. Keep the INTERBUS cable away from noise sources.
- Turn power off before wiring the INTERBUS cable. Make sure of correct wiring before turning power on.
- Use a special INTERBUS cable and connect the cable as shown below. Use D-sub connectors made of metal or made of plastic with metallic plating. Connect the cable shield with the connector housing electrically.
- INTERBUS Cable Connector Pinouts

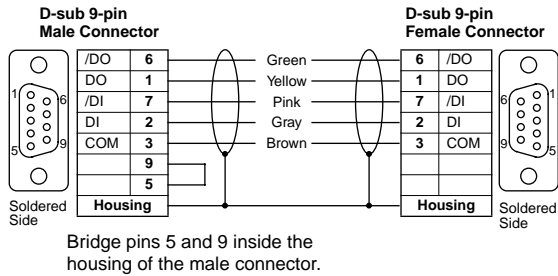

- Stripping and Clamping Cable Ends

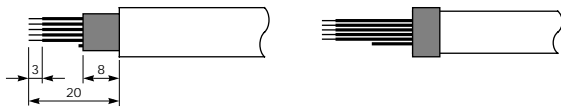

First, strip the cable sheath 20 mm from both ends of the cable and shorten the braided screen by 12 mm.

Bare the core ends 3 mm.

Next, place the braided screen evenly around the cable sheath.

Clamp the shield under the cable grip in the connector housing for conductive connection with the housing.

- Leave open the remote out connector at the last station in the network.
- Supply power to each slave station or to each group of stations separately.
- Master and slave stations may be powered up in any order. But, if a slave station is not powered up while the master is in preparation for transmission, a network error will result.
- Causes of network errors include disconnection or short-circuit of the network cable, strong external noise, invalid command sent to the master station, momentary power voltage drop below the minimum power voltage, faulty transmission line, incorrect cable, and transmission longer than the rated distance.
- When a network error occurs, all outputs are turned off.
- For further information on INTERBUS, read documents published by the INTERBUS CLUB.

16 Point Transistor Source Output

SX5S-SBT16K

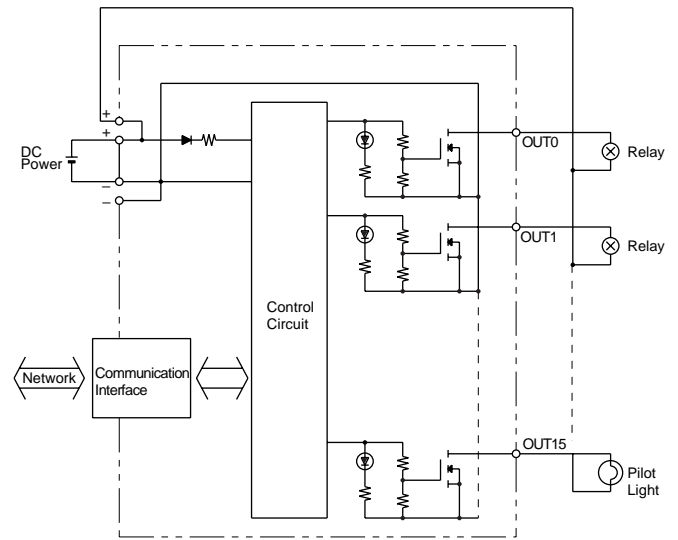

16 Point Transistor Sink Output

SX5S-SBT16P

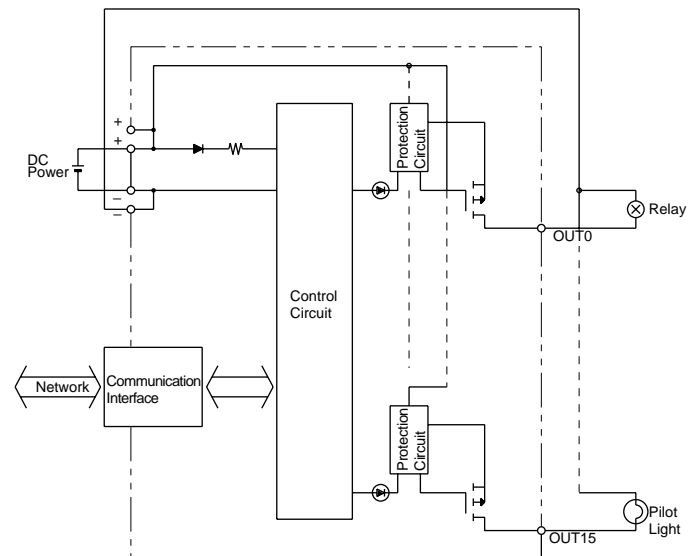

8 Point Source Input & 8 Point Transistor Sink Output Module (INTERBUS)

Key features include:

- Communicate with Interbus network
- Low cost 8 point source input and 8 point sink output module
- Easy and convenient detachable upper/lower terminal plugs

Input Type	Source Input/Sink Output
Part Number	SX5S-SBM16K

DC Input / Transistor Sink Output Type

Type No.	SX5S-SBM16K
I/O Type	Source input / sink output
Input	
Input Logic	Active Low
Input Points	8 points
Input Type	No-voltage input (2-wire DC sensor, 3-wire NPN sensor, no-voltage contact)
Rated Input Voltage	24V DC
Input Voltage Range	0 to the power voltage
ON Voltage	6V maximum
OFF Voltage	10V minimum
Input Current	7 mA/24V DC
Common	1 common
Output	
Output Points	8 points
Output Type	N-channel MOS open drain
Rated Load Voltage	24V DC
Load Voltage Range	3 to 30V DC
Maximum Load Current	0.5A/point
Commons/Current	1 common/4A
Short-circuit Protection	No
Current Draw	140 mA

Terminal Arrangement

Upper Terminal Plug (SX9Z-SS1)		Lower Terminal Plug (SX9Z-SS3)	
Symbol	Signal	Symbol	Signal
+	COM (+)	+	POWER (+)
-	COM (-)	-	POWER (-)
0	IN0	0	OUT0
1	IN1	1	OUT1
2	IN2	2	OUT2
3	IN3	3	OUT3
4	IN4	4	OUT4
5	IN5	5	OUT5
6	IN6	6	OUT6
7	IN7	7	OUT7

J

Communication Speed and Distance

Bus	Baud Rate	Transmission Distance
INTERBUS	500 kbps	400m (between slaves) 12.8 km (total length)

Communication Cables

Bus	Network I/F Connector (on the module)	Cable
INTERBUS	9-pin D-sub connector Remote-in: Male Remote-out: Female	INTERBUS cable

Communication Configuration

Type No.	ID Code	Station Type	Data Length	Data Address
SX5S-SBM16K	03hex	Remote Bus Station with Digital I/Os	1 byte (8 in / 8 out)	Byte 0 (Input) 7 0 Byte 0 (Output) 7 0

Wiring INTERBUS Cable

- Do not install the INTERBUS cable in parallel with or close to motor lines. Keep the INTERBUS cable away from noise sources.
- Turn power off before wiring the INTERBUS cable. Make sure of correct wiring before turning power on.
- Use a special INTERBUS cable and connect the cable as shown below. Use D-sub connectors made of metal or made of plastic with metallic plating. Connect the cable shield with the connector housing electrically.
- INTERBUS Cable Connector Pinouts

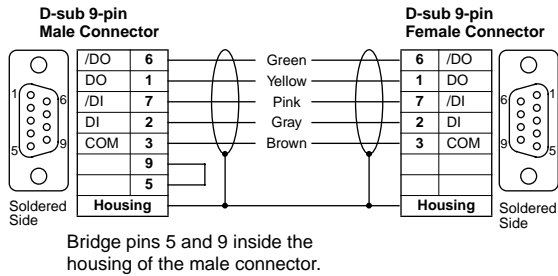

- Stripping and Clamping Cable Ends

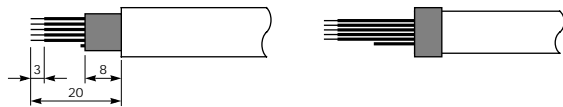

First, strip the cable sheath 20 mm from both ends of the cable and shorten the braided screen by 12 mm.

Bare the core ends 3 mm.

Next, place the braided screen evenly around the cable sheath.

Clamp the shield under the cable grip in the connector housing for conductive connection with the housing.

- Leave open the remote out connector at the last station in the network.
- Supply power to each slave station or to each group of stations separately.
- Master and slave stations may be powered up in any order. But, if a slave station is not powered up while the master is in preparation for transmission, a network error will result.
- Causes of network errors include disconnection or short-circuit of the network cable, strong external noise, invalid command sent to the master station, momentary power voltage drop below the minimum power voltage, faulty transmission line, incorrect cable, and transmission longer than the rated distance.
- When a network error occurs, all outputs are turned off.
- For further information on INTERBUS, read documents published by the INTERBUS CLUB.

8 Point Source Input

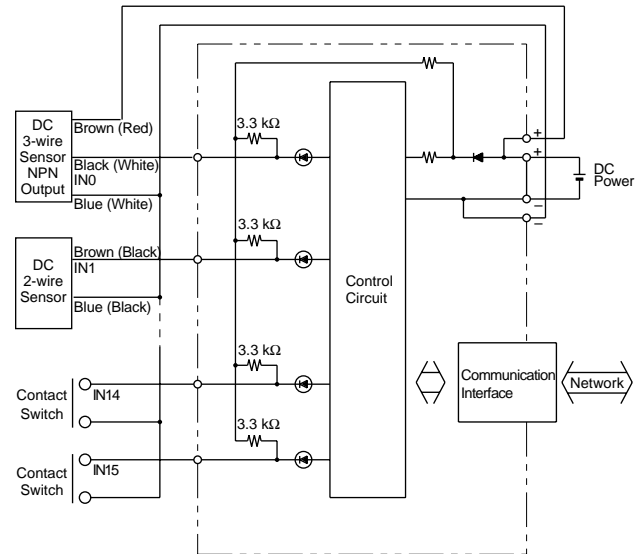

8 Point Transistor Sink Output

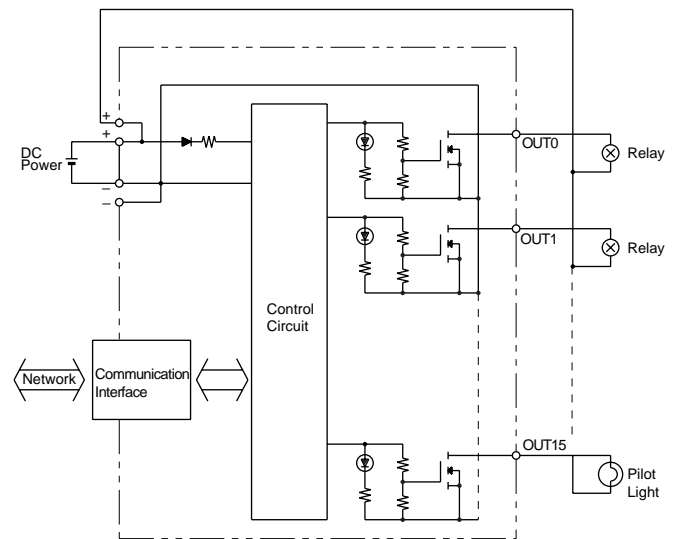

8 Point Sink Input & 8 Point Transistor Source Output Module (INTERBUS)

Key features include:

- Communicate with Interbus network
- Low cost 8 point sink input and 8 point source output module
- Easy and convenient detachable upper/lower terminal plugs
- Transistor protected source output

Input Type	Sink Input/Source Output
Part Number	SX5S-SBM16P

DC Input / Transistor Source Output Type

Type No.	SX5S-SBM16P
I/O Type	Sink input / protect source output
Input	
Input Logic	Active High
Input Points	8 points
Input Type	No-voltage input (2-wire DC sensor, 3-wire PNP sensor, no-voltage contact)
Rated Input Voltage	24V DC
Input Voltage Range	0 to the power voltage
ON Voltage	10V minimum
OFF Voltage	6V maximum
Input Current	6 mA/24V DC
Common	1 common
Output	
Output Points	8 points
Output Type	P-channel MOS open drain
Rated Load Voltage	24V DC
Load Voltage Range	19 to 30V DC
Maximum Load Current	0.5A/point
Commons/Current	1 common/4A
Short-circuit Protection	Yes
Current Draw	140 mA

Terminal Arrangement

Upper Terminal Plug (SX9Z-SS1)		Lower Terminal Plug (SX9Z-SS3)	
Symbol	Signal	Symbol	Signal
+	COM (+)	+	POWER (+)
-	COM (-)	-	POWER (-)
0	IN0	0	OUT0
1	IN1	1	OUT1
2	IN2	2	OUT2
3	IN3	3	OUT3
4	IN4	4	OUT4
5	IN5	5	OUT5
6	IN6	6	OUT6
7	IN7	7	OUT7

Communication Speed and Distance

Bus	Baud Rate	Transmission Distance
INTERBUS	500 kbps	400m (between slaves) 12.8 km (total length)

Communication Cables

Bus	Network I/F Connector (on the module)	Cable
INTERBUS	9-pin D-sub connector Remote-in: Male Remote-out: Female	INTERBUS cable

Communication Configuration

Type No.	ID Code	Station Type	Data Length	Data Address
SX5S-SBM16P	03hex	Remote Bus Station with Digital I/Os	1 byte (8 in / 8 out)	Byte 0 (Input) 7 0 Byte 0 (Output) 7 0

Wiring INTERBUS Cable

- Do not install the INTERBUS cable in parallel with or close to motor lines. Keep the INTERBUS cable away from noise sources.
- Turn power off before wiring the INTERBUS cable. Make sure of correct wiring before turning power on.
- Use a special INTERBUS cable and connect the cable as shown below. Use D-sub connectors made of metal or made of plastic with metallic plating. Connect the cable shield with the connector housing electrically.
- INTERBUS Cable Connector Pinouts

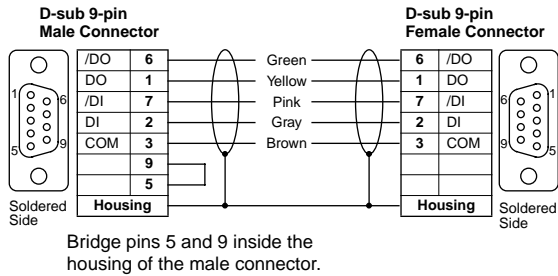

- Stripping and Clamping Cable Ends

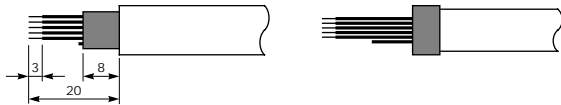

First, strip the cable sheath 20 mm from both ends of the cable and shorten the braided screen by 12 mm.

Bare the core ends 3 mm.

Next, place the braided screen evenly around the cable sheath.

Clamp the shield under the cable grip in the connector housing for conductive connection with the housing.

- Leave open the remote out connector at the last station in the network.
- Supply power to each slave station or to each group of stations separately.
- Master and slave stations may be powered up in any order. But, if a slave station is not powered up while the master is in preparation for transmission, a network error will result.
- Causes of network errors include disconnection or short-circuit of the network cable, strong external noise, invalid command sent to the master station, momentary power voltage drop below the minimum power voltage, faulty transmission line, incorrect cable, and transmission longer than the rated distance.
- When a network error occurs, all outputs are turned off.
- For further information on INTERBUS, read documents published by the INTERBUS CLUB.

8 Point Sink Input

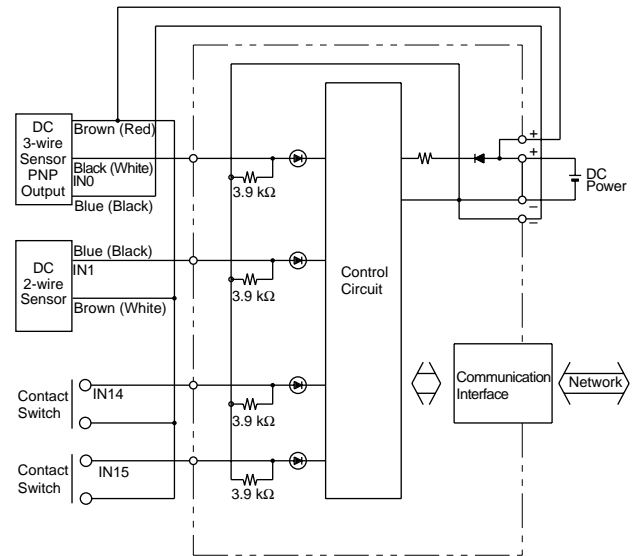

8 Point Transistor Source Output

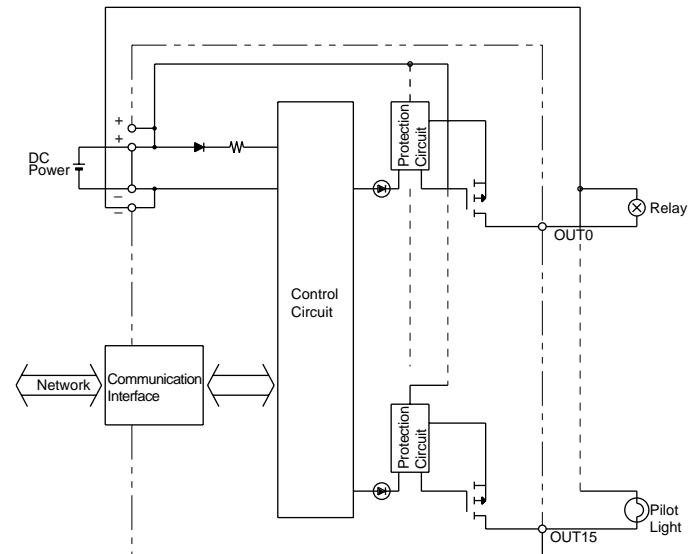

16 Point Transistor Input Modules (DeviceNet)

Key features include:

- Communicate with DeviceNet network
- Low cost 16 point input module (sink/source)
- Easy and convenient detachable upper/lower terminal plugs

Input Type	Source	Sink
Part Number	SX5D-SBN16S	SX5D-SBN16K

DC Input Type

Type No.	SX5D-SBN16S	SX5D-SBN16K
Input Type	DC source input	DC sink input
Input Logic	Active low	Active high
Input Points	16 points	
Input Type	No-voltage input (2-wire DC sensor, 3-wire NPN sensor, no-voltage contact)	No-voltage input (2-wire DC sensor, 3-wire PNP sensor, no-voltage contact)
Rated Input Voltage	24V DC	
Input Voltage Range	0 to the power voltage	
Turn ON Voltage	6V maximum	10V minimum
Turn OFF Voltage	10V minimum	6V maximum
Input Current	mA/24V DC	6 mA/24V DC
Common	1 common	
Current Draw	190 mA	170 mA

Terminal Arrangement

Upper Terminal Plug (SX9Z-SS1)		Lower Terminal Plug (SX9Z-SS2)	
Symbol	Signal	Symbol	Signal
+	COM (+)	+	POWER (+)
-	COM (-)	-	POWER (-)
0	IN0	8	IN8
1	IN1	9	IN9
2	IN2	10	IN10
3	IN3	11	IN11
4	IN4	12	IN12
5	IN5	13	IN13
6	IN6	14	IN14
7	IN7	15	IN15

J

Communication Cables

Bus	Network I/F Connector (on the module)	Cable
DeviceNet	Phoenix Contact 5-pin connector MSTBV2.5/5-GF-5.08AU	DeviceNet cable

Communication Speed and Distance

Bus	Baud Rate	Transmission Distance
DeviceNet	125 kbps	500m [100m] *1
	250 kbps	250m [100m] *1
	500 kbps	100m [100m] *1

Communication Configuration

[Baud Rate Selection]

Baud Rate	DR0	DR1
125 kbps	OFF	OFF
250 kbps	ON	OFF
500 kbps	OFF	ON
(Selection Prohibited)	ON	ON

[Output Hold or Load Off]

Output/Load	H/L
LOAD OFF	OFF
HOLD	ON

[System Reserve]

System Reserve	NO
Fixed to (Selection Prohibited)	OFF ON

Node Address Selection

Node Address	NA0	NA1	NA2	NA3	NA4	NA5	Node Address	NA0	NA1	NA2	NA3	NA4	NA5
0	OFF	OFF	OFF	OFF	OFF	OFF	32	OFF	OFF	OFF	OFF	OFF	ON
1	ON	OFF	OFF	OFF	OFF	OFF	33	ON	OFF	OFF	OFF	OFF	ON
2	OFF	ON	OFF	OFF	OFF	OFF	34	OFF	ON	OFF	OFF	OFF	ON
3	ON	ON	OFF	OFF	OFF	OFF	35	ON	ON	OFF	OFF	OFF	ON
4	OFF	OFF	ON	OFF	OFF	OFF	36	OFF	OFF	ON	OFF	OFF	ON
5	ON	OFF	ON	OFF	OFF	OFF	37	ON	OFF	ON	OFF	OFF	ON
6	OFF	ON	ON	OFF	OFF	OFF	38	OFF	ON	ON	OFF	OFF	ON
7	ON	ON	ON	OFF	OFF	OFF	39	ON	ON	ON	OFF	OFF	ON
8	OFF	OFF	OFF	ON	OFF	OFF	40	OFF	OFF	OFF	ON	OFF	ON
9	ON	OFF	OFF	ON	OFF	OFF	41	ON	OFF	OFF	ON	OFF	ON
10	OFF	ON	OFF	ON	OFF	OFF	42	OFF	ON	OFF	ON	OFF	ON
11	ON	ON	OFF	ON	OFF	OFF	43	ON	ON	OFF	ON	OFF	ON
12	OFF	OFF	ON	ON	OFF	OFF	44	OFF	OFF	ON	ON	OFF	ON
13	ON	OFF	ON	ON	OFF	OFF	45	ON	OFF	ON	ON	OFF	ON
14	OFF	ON	ON	ON	OFF	OFF	46	OFF	ON	ON	ON	OFF	ON
15	ON	ON	ON	ON	OFF	OFF	47	ON	ON	ON	ON	OFF	ON
16	OFF	OFF	OFF	OFF	ON	OFF	48	OFF	OFF	OFF	OFF	ON	ON
17	ON	OFF	OFF	OFF	ON	OFF	49	ON	OFF	OFF	OFF	ON	ON
18	OFF	ON	OFF	OFF	ON	OFF	50	OFF	ON	OFF	OFF	ON	ON
19	ON	ON	OFF	OFF	ON	OFF	51	ON	ON	OFF	OFF	ON	ON
20	OFF	OFF	ON	OFF	ON	OFF	52	OFF	OFF	ON	OFF	ON	ON
21	ON	OFF	ON	OFF	ON	OFF	53	ON	OFF	ON	OFF	ON	ON
22	OFF	ON	ON	OFF	ON	OFF	54	OFF	ON	ON	OFF	ON	ON
23	ON	ON	ON	OFF	ON	OFF	55	ON	ON	ON	OFF	ON	ON
24	OFF	OFF	OFF	ON	ON	OFF	56	OFF	OFF	OFF	ON	ON	ON
25	ON	OFF	OFF	ON	ON	OFF	57	ON	OFF	OFF	ON	ON	ON
26	OFF	ON	OFF	ON	ON	OFF	58	OFF	ON	OFF	ON	ON	ON
27	ON	ON	OFF	ON	ON	OFF	59	ON	ON	OFF	ON	ON	ON
28	OFF	OFF	ON	ON	ON	OFF	60	OFF	OFF	ON	ON	ON	ON
29	ON	OFF	ON	ON	ON	OFF	61	ON	OFF	ON	ON	ON	ON
30	OFF	ON	ON	ON	ON	OFF	62	OFF	ON	ON	ON	ON	ON
31	ON	ON	ON	ON	ON	OFF	63	ON	ON	ON	ON	ON	ON

Wiring DeviceNet Cable

- DeviceNet requires two power voltages; one for communication and the other for internal circuit and load.
- Use a special DeviceNet cable for connecting to the DeviceNet network.
- Connect the core wires of the cable to terminals identified by labels of matching colors.
- DeviceNet Cable

Cable	Type No.	Maker
Thick Cable	1485C-P1A50	Rockwell Automation
Thin Cable	1485C-P1-C150	

J

16 Point Source Input

SX5D-SBN16S

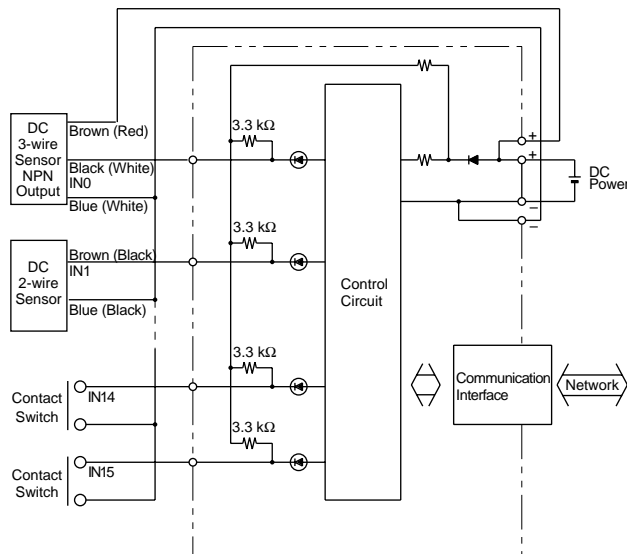

16 Point Sink Input

SX5D-SBN16K

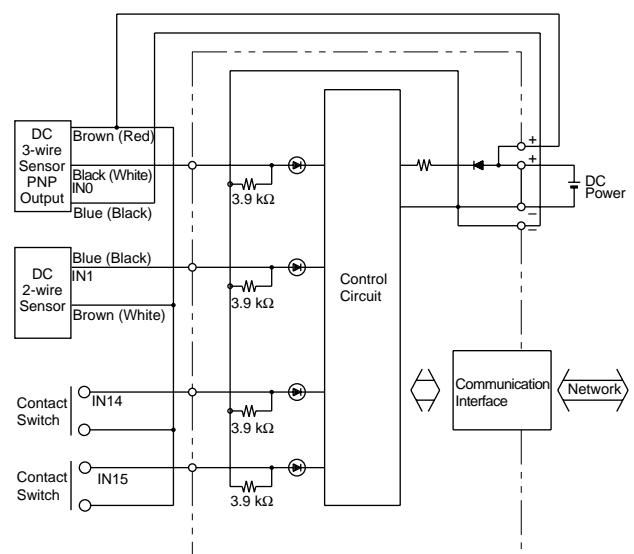

8 Point Relay Output Module (DeviceNet)



Key features include:

- Communicate with DeviceNet network
- Low cost 8 point relay output module
- Easy and convenient detachable upper/lower terminal plugs
- Handles current up to 5A per point

Input Type	Relay Output
Part Number	SX5D-SBR08

Relay Output Type

Type No.	SX5D-SBR08
Output Type	Relay output
Output Points	8 points
Output Type	1NO relay contact
Rated Load Voltage	250V AC, 24V DC
Maximum Load Current	5A/point
Commons/Current	8 commons/5A
Current Draw	120 mA, SX5L
Built-in Relay	PCB mount, not replaceable

Rated Relay Contact

Maximum Applicable Voltage	250V AC, 125V DC	
Maximum Current	5A	
Rated Load (resistive load)	250V AC/5A, 24V DC/5A	
Minimum Applicable Load	1V DC / 1mA	
Life	Mechanical	20,000,000 operations minimum (18,000 operations/ hour)
	Electrical	See Electrical Life Curve on next page (1,800 operations/ hour)

Communication Cables

Bus	Network I/F Connector (on the module)	Cable
DeviceNet	Phoenix Contact 5-pin connector MSTBV2.5/5-GF-5.08AU	DeviceNet cable

Terminal Arrangement

Upper Terminal Plug (SX9Z-SS4)		Lower Terminal Plug (SX9Z-SS2)	
Symbol	Signal	Symbol	Signal
+	COM (+)	+	POWER (+)
-	COM (-)	-	POWER (-)
0	OUT0	4	OUT4
C0	COM0	C4	COM4
1	OUT1	5	OUT5
C1	COM1	C5	COM5
2	OUT2	6	OUT6
C2	COM2	C6	COM6
3	OUT3	7	OUT7
C3	COM3	C7	COM7

J

Communication Speed and Distance

Bus	Baud Rate	Transmission Distance
DeviceNet	125 kbps	500m [100m] *1
	250 kbps	250m [100m] *1
	500 kbps	100m [100m] *1

Communication Configuration

[Baud Rate Selection]

Baud Rate	DR0	DR1
125 kbps	OFF	OFF
250 kbps	ON	OFF
500 kbps	OFF	ON
(Selection Prohibited)	ON	ON

[Output Hold or Load Off]

Output/Load	H/L
LOAD OFF	OFF
HOLD	ON

[System Reserve]

System Reserve	NO
Fixed to	OFF
(Selection Prohibited)	ON

Node Address Selection

Node Address	NA0	NA1	NA2	NA3	NA4	NA5	Node Address	NA0	NA1	NA2	NA3	NA4	NA5
0	OFF	OFF	OFF	OFF	OFF	OFF	32	OFF	OFF	OFF	OFF	OFF	ON
1	ON	OFF	OFF	OFF	OFF	OFF	33	ON	OFF	OFF	OFF	OFF	ON
2	OFF	ON	OFF	OFF	OFF	OFF	34	OFF	ON	OFF	OFF	OFF	ON
3	ON	ON	OFF	OFF	OFF	OFF	35	ON	ON	OFF	OFF	OFF	ON
4	OFF	OFF	ON	OFF	OFF	OFF	36	OFF	OFF	ON	OFF	OFF	ON
5	ON	OFF	ON	OFF	OFF	OFF	37	ON	OFF	ON	OFF	OFF	ON
6	OFF	ON	ON	OFF	OFF	OFF	38	OFF	ON	ON	OFF	OFF	ON
7	ON	ON	ON	OFF	OFF	OFF	39	ON	ON	ON	OFF	OFF	ON
8	OFF	OFF	OFF	ON	OFF	OFF	40	OFF	OFF	OFF	ON	OFF	ON
9	ON	OFF	OFF	ON	OFF	OFF	41	ON	OFF	OFF	ON	OFF	ON
10	OFF	ON	OFF	ON	OFF	OFF	42	OFF	ON	OFF	ON	OFF	ON
11	ON	ON	OFF	ON	OFF	OFF	43	ON	ON	OFF	ON	OFF	ON
12	OFF	OFF	ON	ON	OFF	OFF	44	OFF	OFF	ON	ON	OFF	ON
13	ON	OFF	ON	ON	OFF	OFF	45	ON	OFF	ON	ON	OFF	ON
14	OFF	ON	ON	ON	OFF	OFF	46	OFF	ON	ON	ON	OFF	ON
15	ON	ON	ON	ON	OFF	OFF	47	ON	ON	ON	ON	OFF	ON
16	OFF	OFF	OFF	OFF	ON	OFF	48	OFF	OFF	OFF	OFF	ON	ON
17	ON	OFF	OFF	OFF	ON	OFF	49	ON	OFF	OFF	OFF	ON	ON
18	OFF	ON	OFF	OFF	ON	OFF	50	OFF	ON	OFF	OFF	ON	ON
19	ON	ON	OFF	OFF	ON	OFF	51	ON	ON	OFF	OFF	ON	ON
20	OFF	OFF	ON	OFF	ON	OFF	52	OFF	OFF	ON	OFF	ON	ON
21	ON	OFF	ON	OFF	ON	OFF	53	ON	OFF	ON	OFF	ON	ON
22	OFF	ON	ON	OFF	ON	OFF	54	OFF	ON	ON	OFF	ON	ON
23	ON	ON	ON	OFF	ON	OFF	55	ON	ON	ON	OFF	ON	ON
24	OFF	OFF	OFF	ON	ON	OFF	56	OFF	OFF	OFF	ON	ON	ON
25	ON	OFF	OFF	ON	ON	OFF	57	ON	OFF	OFF	ON	ON	ON
26	OFF	ON	OFF	ON	ON	OFF	58	OFF	ON	OFF	ON	ON	ON
27	ON	ON	OFF	ON	ON	OFF	59	ON	ON	OFF	ON	ON	ON
28	OFF	OFF	ON	ON	ON	OFF	60	OFF	OFF	ON	ON	ON	ON
29	ON	OFF	ON	ON	ON	OFF	61	ON	OFF	ON	ON	ON	ON
30	OFF	ON	ON	ON	ON	OFF	62	OFF	ON	ON	ON	ON	ON
31	ON	ON	ON	ON	ON	OFF	63	ON	ON	ON	ON	ON	ON

Wiring DeviceNet Cable

- DeviceNet requires two power voltages; one for communication and the other for internal circuit and load.
- Use a special DeviceNet cable for connecting to the DeviceNet network.
- Connect the core wires of the cable to terminals identified by labels of matching colors.
- DeviceNet Cable

Cable	Type No.	Maker
Thick Cable	1485C-P1A50	Rockwell Automation
Thin Cable	1485C-P1-C150	

8 Point Relay Output

SX5D-SBR08

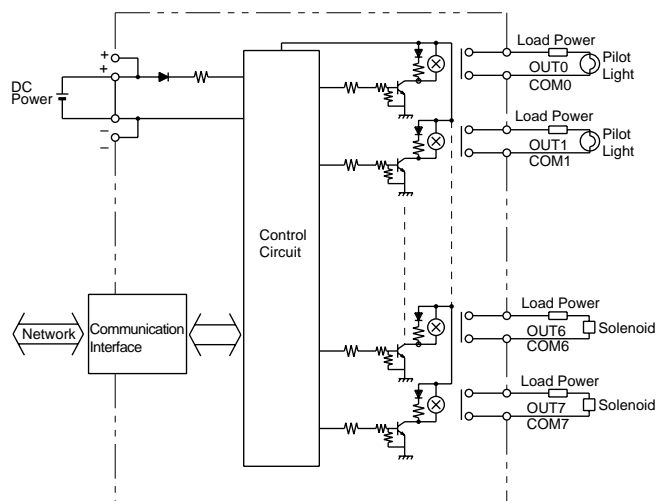

Reference Data

- ♦ Electrical Life Curve: Relay in SX5*-SBR08
- **Note 1:** AC/DC Resistive Load
- Operating frequency: 1800 operations/hour

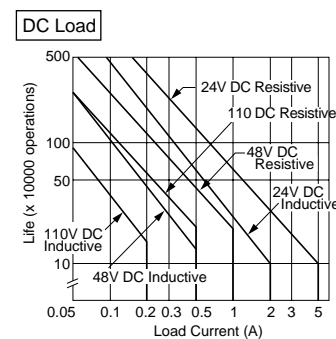
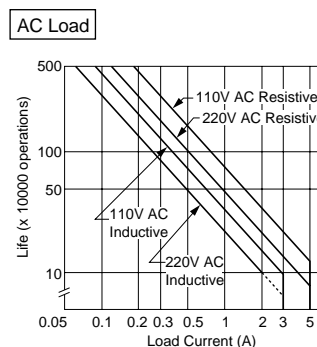

Duty ratio: 40%

- **Note 2:** AC Inductive Load

Line	Making Current	Breaking Current	Frequency	Duty Ratio
Solid	10 I, cos θ = 0.7	I, cos θ = 0.3 to 0.4	1800 operations/h	40%
Dashed	5 I, cos θ = 0.7	I, cos θ = 0.3 to 0.4	300 operations/h	

- **Note 3:** DC Inductive Load
Operating frequency: 1800 operations/hour
Duty ratio: 40%
Time constant: L/R = 15 msec

16 Point Transistor Output Modules (DeviceNet)

Key features include:

- Communicate with DeviceNet network
- Low cost 16 point transistor output module (sink/source)
- Easy and convenient detachable upper/lower terminal plugs
- The source output is protected against overload

Input Type	Source	Sink
Part Number	SX5D-SBT16K	SX5D-SBT16P

Transistor Output Type

Type No.	SX5D-SBT16K	SX5D-SBT16P
Output Type	Sink output	Protect source output
Output Points	16 points	
Output Type	N-channel MOS open drain	P-channel MOS open drain
Rated Load Voltage	24V DC	
Load Voltage Range	3 to 30V DC	19 to 30V DC
Maximum Load Current	0.5A/point	
Commons/Current	1 common/6A	
Short-circuit Protection	No	Yes
Current Draw	70 mA	100 mA

Terminal Arrangement

Upper Terminal Plug (SX9Z-SS1)		Lower Terminal Plug (SX9Z-SS2)	
Symbol	Signal	Symbol	Signal
+	COM (+)	+	POWER (+)
-	COM (-)	-	POWER (-)
0	OUT0	8	OUT8
1	OUT1	9	OUT9
2	OUT2	10	OUT10
3	OUT3	11	OUT11
4	OUT4	12	OUT12
5	OUT5	13	OUT13
6	OUT6	14	OUT14
7	OUT7	15	OUT15

J

Communication Cables

Bus	Network I/F Connector (on the module)	Cable
DeviceNet	Phoenix Contact 5-pin connector MSTBV2.5/5-GF-5.08AU	DeviceNet cable

Communication Speed and Distance

Bus	Baud Rate	Transmission Distance
DeviceNet	125 kbps	500m [100m] *1
	250 kbps	250m [100m] *1
	500 kbps	100m [100m] *1

Communication Configuration

[Baud Rate Selection]		
Baud Rate	DR0	DR1
125 kbps	OFF	OFF
250 kbps	ON	OFF
500 kbps	OFF	ON
(Selection Prohibited)	ON	ON

[Output Hold or Load Off]	
Output/Load	H/L
LOAD OFF	OFF
HOLD	ON

[System Reserve]	
System Reserve	NO
Fixed to	OFF
(Selection Prohibited)	ON

Node Address Selection

Node Address	NA0	NA1	NA2	NA3	NA4	NA5	Node Address	NA0	NA1	NA2	NA3	NA4	NA5
0	OFF	OFF	OFF	OFF	OFF	OFF	32	OFF	OFF	OFF	OFF	OFF	ON
1	ON	OFF	OFF	OFF	OFF	OFF	33	ON	OFF	OFF	OFF	OFF	ON
2	OFF	ON	OFF	OFF	OFF	OFF	34	OFF	ON	OFF	OFF	OFF	ON
3	ON	ON	OFF	OFF	OFF	OFF	35	ON	ON	OFF	OFF	OFF	ON
4	OFF	OFF	ON	OFF	OFF	OFF	36	OFF	OFF	ON	OFF	OFF	ON
5	ON	OFF	ON	OFF	OFF	OFF	37	ON	OFF	ON	OFF	OFF	ON
6	OFF	ON	ON	OFF	OFF	OFF	38	OFF	ON	ON	OFF	OFF	ON
7	ON	ON	ON	OFF	OFF	OFF	39	ON	ON	ON	OFF	OFF	ON
8	OFF	OFF	OFF	ON	OFF	OFF	40	OFF	OFF	OFF	ON	OFF	ON
9	ON	OFF	OFF	ON	OFF	OFF	41	ON	OFF	OFF	ON	OFF	ON
10	OFF	ON	OFF	ON	OFF	OFF	42	OFF	ON	OFF	ON	OFF	ON
11	ON	ON	OFF	ON	OFF	OFF	43	ON	ON	OFF	ON	OFF	ON
12	OFF	OFF	ON	ON	OFF	OFF	44	OFF	OFF	ON	ON	OFF	ON
13	ON	OFF	ON	ON	OFF	OFF	45	ON	OFF	ON	ON	OFF	ON
14	OFF	ON	ON	ON	OFF	OFF	46	OFF	ON	ON	ON	OFF	ON
15	ON	ON	ON	ON	OFF	OFF	47	ON	ON	ON	ON	OFF	ON
16	OFF	OFF	OFF	OFF	ON	OFF	48	OFF	OFF	OFF	OFF	ON	ON
17	ON	OFF	OFF	OFF	ON	OFF	49	ON	OFF	OFF	OFF	ON	ON
18	OFF	ON	OFF	OFF	ON	OFF	50	OFF	ON	OFF	OFF	ON	ON
19	ON	ON	OFF	OFF	ON	OFF	51	ON	ON	OFF	OFF	ON	ON
20	OFF	OFF	ON	OFF	ON	OFF	52	OFF	OFF	ON	OFF	ON	ON
21	ON	OFF	ON	OFF	ON	OFF	53	ON	OFF	ON	OFF	ON	ON
22	OFF	ON	ON	OFF	ON	OFF	54	OFF	ON	ON	OFF	ON	ON
23	ON	ON	ON	OFF	ON	OFF	55	ON	ON	ON	OFF	ON	ON
24	OFF	OFF	OFF	ON	ON	OFF	56	OFF	OFF	OFF	ON	ON	ON
25	ON	OFF	OFF	ON	ON	OFF	57	ON	OFF	OFF	ON	ON	ON
26	OFF	ON	OFF	ON	ON	OFF	58	OFF	ON	OFF	ON	ON	ON
27	ON	ON	OFF	ON	ON	OFF	59	ON	ON	OFF	ON	ON	ON
28	OFF	OFF	ON	ON	ON	OFF	60	OFF	OFF	ON	ON	ON	ON
29	ON	OFF	ON	ON	ON	OFF	61	ON	OFF	ON	ON	ON	ON
30	OFF	ON	ON	ON	ON	OFF	62	OFF	ON	ON	ON	ON	ON
31	ON	ON	ON	ON	ON	OFF	63	ON	ON	ON	ON	ON	ON

Wiring DeviceNet Cable

- DeviceNet requires two power voltages; one for communication and the other for internal circuit and load.
- Use a special DeviceNet cable for connecting to the DeviceNet network.
- Connect the core wires of the cable to terminals identified by labels of matching colors.
- DeviceNet Cable

Cable	Type No.	Maker
Thick Cable	1485C-P1A50	Rockwell Automation
Thin Cable	1485C-P1-C150	

J

16 Point Transistor Source Output

SX5D-SBT16K

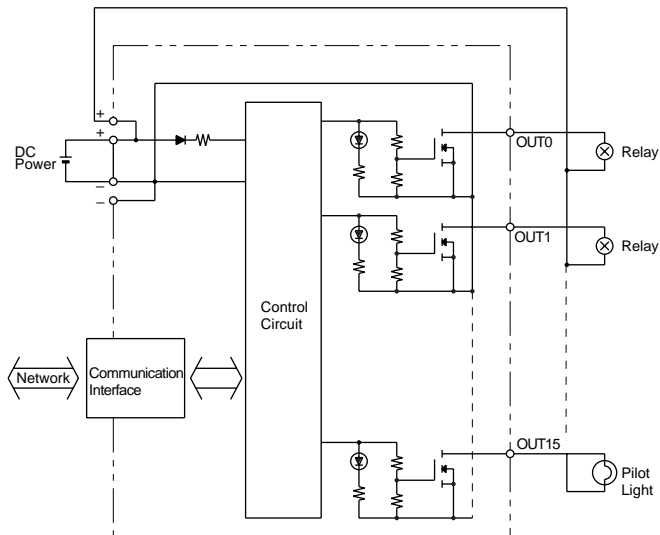

16 Point Transistor Source Output

SX5D-SBT16P

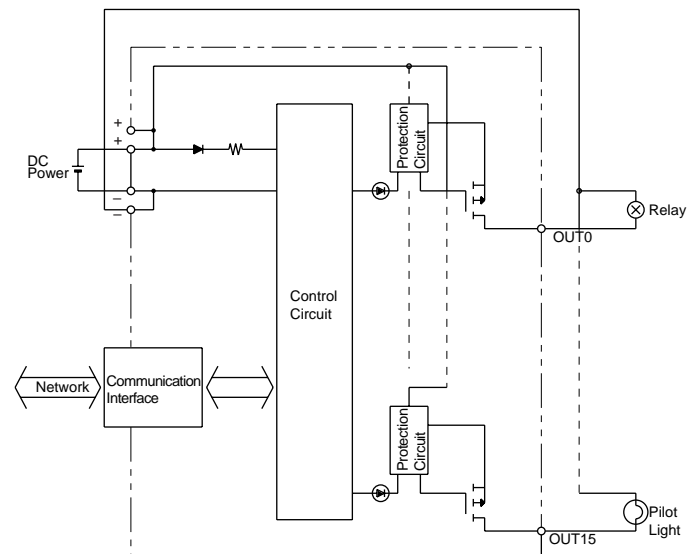

8 Point Source Input & 8 Point Transistor Sink Output Module (DeviceNet)

Key features include:

- Communicate with DeviceNet network
- Low cost 8 point source input and 8 point sink output module
- Easy and convenient detachable upper/lower terminal plugs

Input Type	Source Input/Sink Output
Part Number	SX5D-SBM16K

DC Input / Transistor Sink Output Type

Type No.	SX5D-SBM16K
I/O Type	Source input / sink output
Input	
Input Logic	Active Low
Input Points	8 points
Input Type	No-voltage input (2-wire DC sensor, 3-wire NPN sensor, no-voltage contact)
Rated Input Voltage	24V DC
Input Voltage Range	0 to the power voltage
ON Voltage	6V maximum
OFF Voltage	10V minimum
Input Current	7 mA/24V DC
Common	1 common
Output	
Output Points	8 points
Output Type	N-channel MOS open drain
Rated Load Voltage	24V DC
Load Voltage Range	3 to 30V DC
Maximum Load Current	0.5A/point
Commons/Current	1 common/4A
Short-circuit Protection	No
Current Draw	140 mA

Terminal Arrangement

Upper Terminal Plug (SX9Z-SS1)		Lower Terminal Plug (SX9Z-SS3)	
Symbol	Signal	Symbol	Signal
+	COM (+)	+	POWER (+)
-	COM (-)	-	POWER (-)
0	IN0	0	OUT0
1	IN1	1	OUT1
2	IN2	2	OUT2
3	IN3	3	OUT3
4	IN4	4	OUT4
5	IN5	5	OUT5
6	IN6	6	OUT6
7	IN7	7	OUT7

J

Communication Speed and Distance

Bus	Baud Rate	Transmission Distance
DeviceNet	125 kbps	500m [100m] *1
	250 kbps	250m [100m] *1
	500 kbps	100m [100m] *1

Communication Cables

Bus	Network I/F Connector (on the module)	Cable
DeviceNet	Phoenix Contact 5-pin connector MSTBV2.5/5-GF-5.08AU	DeviceNet cable

Communication Configuration

[Baud Rate Selection]		
Baud Rate	DR0	DR1
125 kbps	OFF	OFF
250 kbps	ON	OFF
500 kbps	OFF	ON
(Selection Prohibited)	ON	ON

[Output Hold or Load Off]	
Output/Load	H/L
LOAD OFF	OFF
HOLD	ON

[System Reserve]	
System Reserve	NO
Fixed to	OFF
(Selection Prohibited)	ON

Node Address Selection

Node Address	NA0	NA1	NA2	NA3	NA4	NA5	Node Address	NA0	NA1	NA2	NA3	NA4	NA5
0	OFF	OFF	OFF	OFF	OFF	OFF	32	OFF	OFF	OFF	OFF	OFF	ON
1	ON	OFF	OFF	OFF	OFF	OFF	33	ON	OFF	OFF	OFF	OFF	ON
2	OFF	ON	OFF	OFF	OFF	OFF	34	OFF	ON	OFF	OFF	OFF	ON
3	ON	ON	OFF	OFF	OFF	OFF	35	ON	ON	OFF	OFF	OFF	ON
4	OFF	OFF	ON	OFF	OFF	OFF	36	OFF	OFF	ON	OFF	OFF	ON
5	ON	OFF	ON	OFF	OFF	OFF	37	ON	OFF	ON	OFF	OFF	ON
6	OFF	ON	ON	OFF	OFF	OFF	38	OFF	ON	ON	OFF	OFF	ON
7	ON	ON	ON	OFF	OFF	OFF	39	ON	ON	ON	OFF	OFF	ON
8	OFF	OFF	OFF	ON	OFF	OFF	40	OFF	OFF	OFF	ON	OFF	ON
9	ON	OFF	OFF	ON	OFF	OFF	41	ON	OFF	OFF	ON	OFF	ON
10	OFF	ON	OFF	ON	OFF	OFF	42	OFF	ON	OFF	ON	OFF	ON
11	ON	ON	OFF	ON	OFF	OFF	43	ON	ON	OFF	ON	OFF	ON
12	OFF	OFF	ON	ON	OFF	OFF	44	OFF	OFF	ON	ON	OFF	ON
13	ON	OFF	ON	ON	OFF	OFF	45	ON	OFF	ON	ON	OFF	ON
14	OFF	ON	ON	ON	OFF	OFF	46	OFF	ON	ON	ON	OFF	ON
15	ON	ON	ON	ON	OFF	OFF	47	ON	ON	ON	ON	OFF	ON
16	OFF	OFF	OFF	OFF	ON	OFF	48	OFF	OFF	OFF	OFF	ON	ON
17	ON	OFF	OFF	OFF	ON	OFF	49	ON	OFF	OFF	OFF	ON	ON
18	OFF	ON	OFF	OFF	ON	OFF	50	OFF	ON	OFF	OFF	ON	ON
19	ON	ON	OFF	OFF	ON	OFF	51	ON	ON	OFF	OFF	ON	ON
20	OFF	OFF	ON	OFF	ON	OFF	52	OFF	OFF	ON	OFF	ON	ON
21	ON	OFF	ON	OFF	ON	OFF	53	ON	OFF	ON	OFF	ON	ON
22	OFF	ON	ON	OFF	ON	OFF	54	OFF	ON	ON	OFF	ON	ON
23	ON	ON	ON	OFF	ON	OFF	55	ON	ON	ON	OFF	ON	ON
24	OFF	OFF	OFF	ON	ON	OFF	56	OFF	OFF	OFF	ON	ON	ON
25	ON	OFF	OFF	ON	ON	OFF	57	ON	OFF	OFF	ON	ON	ON
26	OFF	ON	OFF	ON	ON	OFF	58	OFF	ON	OFF	ON	ON	ON
27	ON	ON	OFF	ON	ON	OFF	59	ON	ON	OFF	ON	ON	ON
28	OFF	OFF	ON	ON	ON	OFF	60	OFF	OFF	ON	ON	ON	ON
29	ON	OFF	ON	ON	ON	OFF	61	ON	OFF	ON	ON	ON	ON
30	OFF	ON	ON	ON	ON	OFF	62	OFF	ON	ON	ON	ON	ON
31	ON	ON	ON	ON	ON	OFF	63	ON	ON	ON	ON	ON	ON

Wiring DeviceNet Cable

- DeviceNet requires two power voltages; one for communication and the other for internal circuit and load.
- Use a special DeviceNet cable for connecting to the DeviceNet network.
- Connect the core wires of the cable to terminals identified by labels of matching colors.
- DeviceNet Cable

Cable	Type No.	Maker
Thick Cable	1485C-P1A50	Rockwell Automation
Thin Cable	1485C-P1-C150	

J

8 Point Source Input

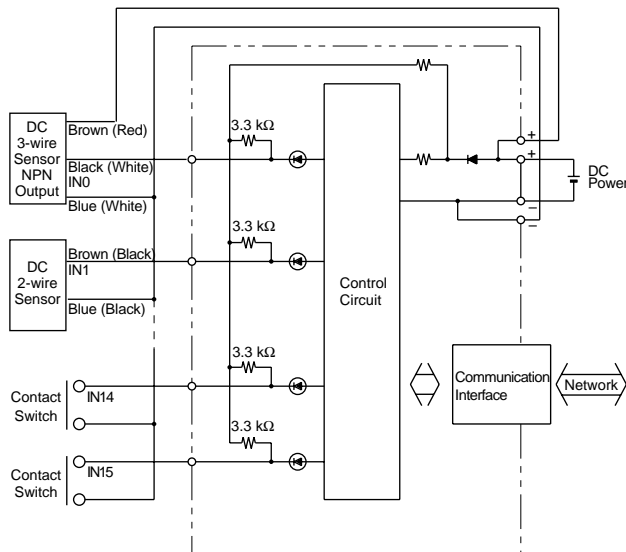

8 Point Transistor Sink Output

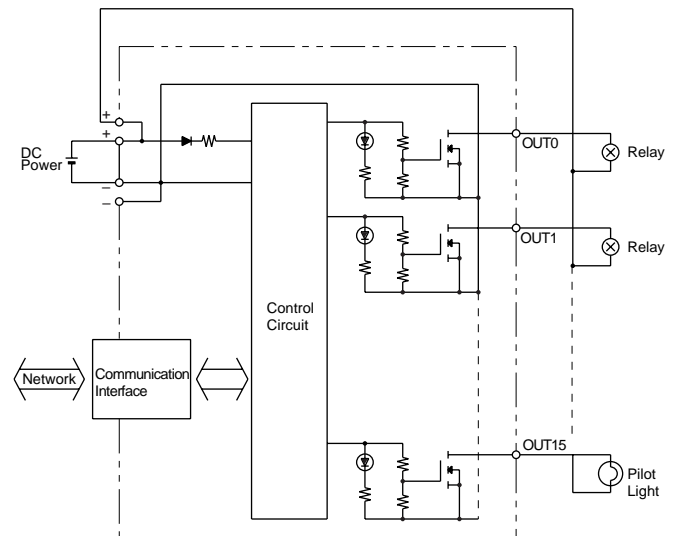

8 Point Sink Input & 8 Point Transistor Source Output Module (DeviceNet)

Key features include:

- Communicate with DeviceNet network
- Low cost 8 point sink input and 8 point source output module
- Easy and convenient detachable upper/lower terminal plugs
- Transistor output protected source

Input Type	Sink Input/Source Output
Part Number	SX5D-SBM16P

DC Input / Transistor Source Output Type

Type No.	SX5D-SBM16P
I/O Type	Sink input / protect source output
Input	
Input Logic	Active High
Input Points	8 points
Input Type	No-voltage input (2-wire DC sensor, 3-wire PNP sensor, no-voltage contact)
Rated Input Voltage	24V DC
Input Voltage Range	0 to the power voltage
ON Voltage	10V minimum
OFF Voltage	6V maximum
Input Current	6 mA/24V DC
Common	1 common
Output	
Output Points	8 points
Output Type	P-channel MOS open drain
Rated Load Voltage	24V DC
Load Voltage Range	19 to 30V DC
Maximum Load Current	0.5A/point
Commons/Current	1 common/4A
Short-circuit Protection	Yes
Current Draw	140 mA

Terminal Arrangement

Upper Terminal Plug (SX9Z-SS1)		Lower Terminal Plug (SX9Z-SS3)	
Symbol	Signal	Symbol	Signal
+	COM (+)	+	POWER (+)
-	COM (-)	-	POWER (-)
0	IN0	0	OUT0
1	IN1	1	OUT1
2	IN2	2	OUT2
3	IN3	3	OUT3
4	IN4	4	OUT4
5	IN5	5	OUT5
6	IN6	6	OUT6
7	IN7	7	OUT7

J

Communication Speed and Distance

Bus	Baud Rate	Transmission Distance
DeviceNet	125 kbps	500m [100m] *1
	250 kbps	250m [100m] *1
	500 kbps	100m [100m] *1

Communication Cables

Bus	Network I/F Connector (on the module)	Cable
DeviceNet	Phoenix Contact 5-pin connector MSTBV2.5/5-GF-5.08AU	DeviceNet cable

Communication Configuration

[Baud Rate Selection]		
Baud Rate	DR0	DR1
125 kbps	OFF	OFF
250 kbps	ON	OFF
500 kbps	OFF	ON
(Selection Prohibited)	ON	ON

[Output Hold or Load Off]	
Output/Load	H/L
LOAD OFF	OFF
HOLD	ON

[System Reserve]	
System Reserve	NO
Fixed to	OFF
(Selection Prohibited)	ON

Node Address Selection

Node Address	NA0	NA1	NA2	NA3	NA4	NA5	Node Address	NA0	NA1	NA2	NA3	NA4	NA5
0	OFF	OFF	OFF	OFF	OFF	OFF	32	OFF	OFF	OFF	OFF	OFF	ON
1	ON	OFF	OFF	OFF	OFF	OFF	33	ON	OFF	OFF	OFF	OFF	ON
2	OFF	ON	OFF	OFF	OFF	OFF	34	OFF	ON	OFF	OFF	OFF	ON
3	ON	ON	OFF	OFF	OFF	OFF	35	ON	ON	OFF	OFF	OFF	ON
4	OFF	OFF	ON	OFF	OFF	OFF	36	OFF	OFF	ON	OFF	OFF	ON
5	ON	OFF	ON	OFF	OFF	OFF	37	ON	OFF	ON	OFF	OFF	ON
6	OFF	ON	ON	OFF	OFF	OFF	38	OFF	ON	ON	OFF	OFF	ON
7	ON	ON	ON	OFF	OFF	OFF	39	ON	ON	ON	OFF	OFF	ON
8	OFF	OFF	OFF	ON	OFF	OFF	40	OFF	OFF	OFF	ON	OFF	ON
9	ON	OFF	OFF	ON	OFF	OFF	41	ON	OFF	OFF	ON	OFF	ON
10	OFF	ON	OFF	ON	OFF	OFF	42	OFF	ON	OFF	ON	OFF	ON
11	ON	ON	OFF	ON	OFF	OFF	43	ON	ON	OFF	ON	OFF	ON
12	OFF	OFF	ON	ON	OFF	OFF	44	OFF	OFF	ON	ON	OFF	ON
13	ON	OFF	ON	ON	OFF	OFF	45	ON	OFF	ON	ON	OFF	ON
14	OFF	ON	ON	ON	OFF	OFF	46	OFF	ON	ON	ON	OFF	ON
15	ON	ON	ON	ON	OFF	OFF	47	ON	ON	ON	ON	OFF	ON
16	OFF	OFF	OFF	OFF	ON	OFF	48	OFF	OFF	OFF	OFF	ON	ON
17	ON	OFF	OFF	OFF	ON	OFF	49	ON	OFF	OFF	OFF	ON	ON
18	OFF	ON	OFF	OFF	ON	OFF	50	OFF	ON	OFF	OFF	ON	ON
19	ON	ON	OFF	OFF	ON	OFF	51	ON	ON	OFF	OFF	ON	ON
20	OFF	OFF	ON	OFF	ON	OFF	52	OFF	OFF	ON	OFF	ON	ON
21	ON	OFF	ON	OFF	ON	OFF	53	ON	OFF	ON	OFF	ON	ON
22	OFF	ON	ON	OFF	ON	OFF	54	OFF	ON	ON	OFF	ON	ON
23	ON	ON	ON	OFF	ON	OFF	55	ON	ON	ON	OFF	ON	ON
24	OFF	OFF	OFF	ON	ON	OFF	56	OFF	OFF	OFF	ON	ON	ON
25	ON	OFF	OFF	ON	ON	OFF	57	ON	OFF	OFF	ON	ON	ON
26	OFF	ON	OFF	ON	ON	OFF	58	OFF	ON	OFF	ON	ON	ON
27	ON	ON	OFF	ON	ON	OFF	59	ON	ON	OFF	ON	ON	ON
28	OFF	OFF	ON	ON	ON	OFF	60	OFF	OFF	ON	ON	ON	ON
29	ON	OFF	ON	ON	ON	OFF	61	ON	OFF	ON	ON	ON	ON
30	OFF	ON	ON	ON	ON	OFF	62	OFF	ON	ON	ON	ON	ON
31	ON	ON	ON	ON	ON	OFF	63	ON	ON	ON	ON	ON	ON

Wiring DeviceNet Cable

- DeviceNet requires two power voltages; one for communication and the other for internal circuit and load.
- Use a special DeviceNet cable for connecting to the DeviceNet network.
- Connect the core wires of the cable to terminals identified by labels of matching colors.
- DeviceNet Cable

Cable	Type No.	Maker
Thick Cable	1485C-P1A50	Rockwell Automation
Thin Cable	1485C-P1-C150	

J

8 Point Sink Input

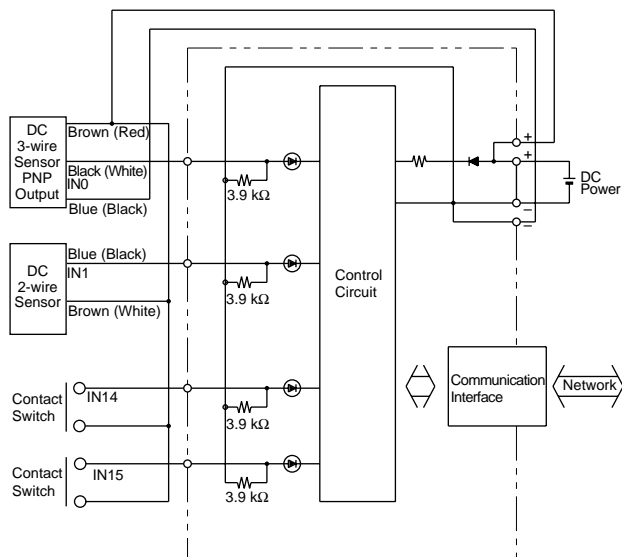

8 Point Transistor Source Output

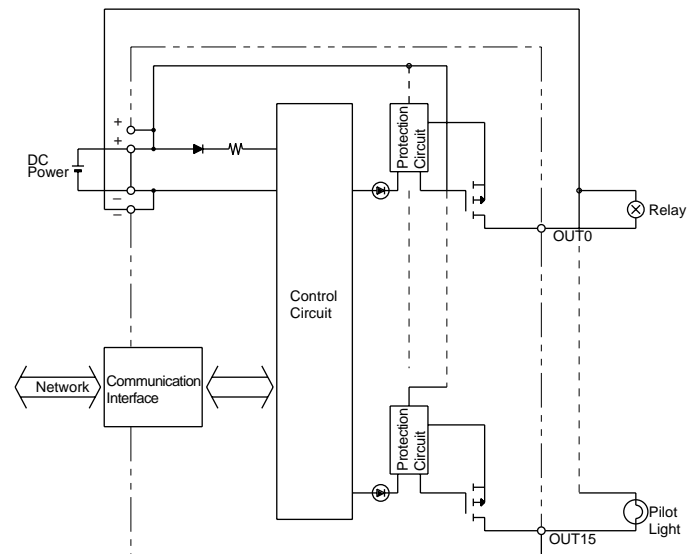

16 Point Transistor Input Modules (LonWorks)

Key features include:

- Communicate with LonWorks network
- Low cost 16 point transistor input module
- Easy and convenient detachable upper/lower terminal plugs

Input Type	Source	Sink
Part Number	SX5L-SBN16S	SX5L-SBN16K

DC Input Type

Type No.	SX5L-SBN16S	SX5L-SBN16K
Input Type	DC source input	DC sink input
Input Logic	Active low	Active high
Input Points	16 points	
Input Type	No-voltage input (2-wire DC sensor, 3-wire NPN sensor, no-voltage contact)	No-voltage input (2-wire DC sensor, 3-wire PNP sensor, no-voltage contact)
Rated Input Voltage	24V DC	
Input Voltage Range	0 to the power voltage	
Turn ON Voltage	6V maximum	10V minimum
Turn OFF Voltage	10V minimum	6V maximum
Input Current	7 mA/24V DC	6 mA/24V DC
Common	1 common	
Current Draw	190 mA	170 mA

Terminal Arrangement

Upper Terminal Plug (SX9Z-SS1)		Lower Terminal Plug (SX9Z-SS2)	
Symbol	Signal	Symbol	Signal
+	COM (+)	+	POWER (+)
-	COM (-)	-	POWER (-)
0	IN0	8	IN8
1	IN1	9	IN9
2	IN2	10	IN10
3	IN3	11	IN11
4	IN4	12	IN12
5	IN5	13	IN13
6	IN6	14	IN14
7	IN7	15	IN15

J

Communication Cables

Bus	Network I/F Connector (on the module)	Cable
LonWorks	Phoenix Contact 2-pin connector MSTBV2.5/2-GF-5.08	Single twisted-pair cable AWG24 to 14 0.2 to 2.5 mm ²

Communication Speed and Distance

Bus	Baud Rate	Transmission Distance
LONWORKS	78 kbps	500m (total length) *2 400m (between nodes)

Communication Configuration

All SX5L Modules:

- The application program of the LonWorks is installed in the Neuron chip of the SX5L module.
- When wink is executed, the RUN LED flashes for 3 seconds in 500-msec increments.
- In the offline mode, the RUN and ERR LEDs go off and all outputs also go off.

SX5L-SBN16*:

- Output network variables are updated only at the transition of the input status.
(When all inputs are off at power-up, network variables are not updated.)
- When nv_update_fails is TRUE(1) while using the data acknowledged service (ACKD), the ERR LED goes on.
- The ERR LED goes off when nv_update_succeeds is TRUE(1).
(When an attempt to send network variables fails, resending does not occur until the input changes status.)

continued

Communication Configuration Continued

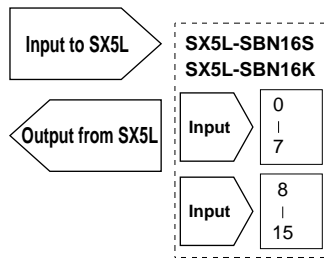

Wiring LONWORKS Cable

- Turn power off before wiring the SX5L to the LonWorks network. Make sure of correct wiring before turning power on. Supply power to each slave station or to each group of stations separately.
- The LONWORKS network uses a twisted-pair cable. The connector has no polarity and the core wires of the twisted-pair cable can be connected to either terminal of the connector.
- The LONWORKS network requires network management to enable communication between nodes, including the SX5L.
- The network management requires an XIF extension. For your XIF extension, find your XIF No., printed on the side of the SX5 module or on the shipping package. The network management is not completed successfully without the XIF extension.

16 Point Source Input

SX5L-SBN16S

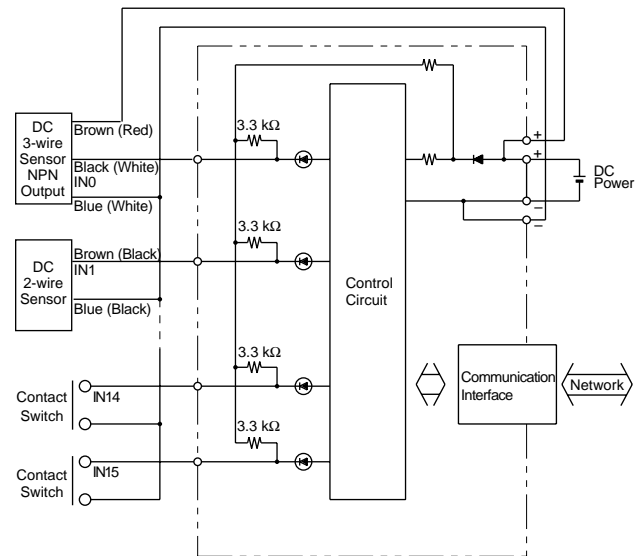

16 Point Sink Input

SX5L-SBN16K

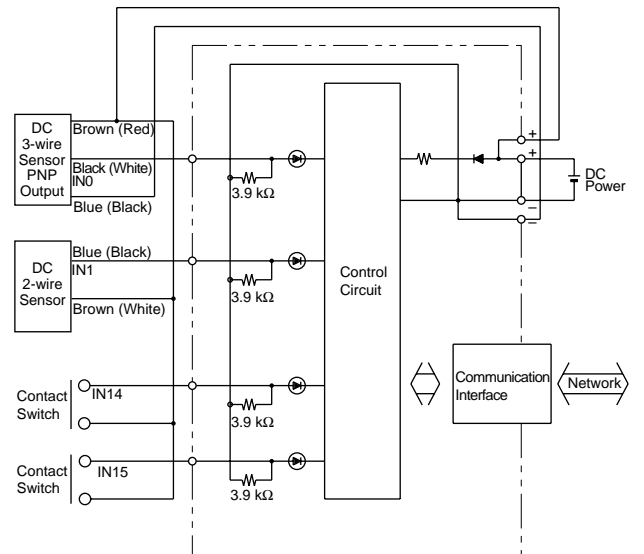

J

8 Point Relay Output Module (LonWorks)



Key features include:

- Communicate with LonWorks network
- Low cost 8 point relay output module
- Easy and convenient detachable upper/lower terminal plugs
- Handles current up to 5A per point

Input Type	Relay Output
Part Number	SX5L-SBR08

Relay Output Type

Type No.	SX5L-SBR08
Output Type	Relay output
Output Points	8 points
Output Type	1NO relay contact
Rated Load Voltage	250V AC, 24V DC
Maximum Load Current	5A/point
Commons/Current	8 commons/5A
Current Draw	80 mA
Built-in Relay	PCB mount, not replaceable

Rated Relay Contact

Maximum Applicable Voltage	250V AC, 125V DC	
Maximum Current	5A	
Rated Load (resistive load)	250V AC/5A, 24V DC/5A	
Minimum Applicable Load	1V DC / 1mA	
Life	Mechanical	20,000,000 operations minimum (18,000 operations/ hour)
	Electrical	See Electrical Life Curve on next page (1,800 operations/ hour)

Communication Cables

Bus	Network I/F Connector (on the module)	Cable
LonWorks	Phoenix Contact 2-pin connector MSTBV2.5/2-GF-5.08	Single twisted-pair cable AWG24 to 14 0.2 to 2.5 mm ²

Communication Speed and Distance

Bus	Baud Rate	Transmission Distance
LONWORKS	78 kbps	500m (total length) *2 400m (between nodes)

Terminal Arrangement

Upper Terminal Plug (SX9Z-SS4)		Lower Terminal Plug (SX9Z-SS2)	
Symbol	Signal	Symbol	Signal
+	COM (+)	+	POWER (+)
-	COM (-)	-	POWER (-)
0	OUT0	4	OUT4
C0	COM0	C4	COM4
1	OUT1	5	OUT5
C1	COM1	C5	COM5
2	OUT2	6	OUT6
C2	COM2	C6	COM6
3	OUT3	7	OUT7
C3	COM3	C7	COM7

Communication Configuration

All SX5L Modules:

- The application program of the LonWorks is installed in the Neuron chip of the SX5L module.
- When wink is executed, the RUN LED flashes for 3 seconds in 500-msec increments.
- In the offline mode, the RUN and ERR LEDs go off and all outputs also go off.

SX5L-SBR08:

- Output is updated only when input network variables are received. (At power-up to the network, all outputs remain off until initial communication starts.)

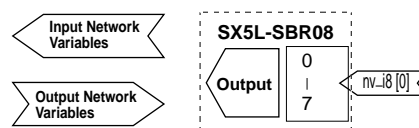

Wiring LONWORKS Cable

- Turn power off before wiring the SX5L to the LonWorks network. Make sure of correct wiring before turning power on. Supply power to each slave station or to each group of stations separately.
- The LONWORKS network uses a twisted-pair cable. The connector has no polarity and the core wires of the twisted-pair cable can be connected to either terminal of the connector.
- The LONWORKS network requires network management to enable communication between nodes, including the SX5L.
- The network management requires an XIF extension. For your XIF extension, find your XIF No., printed on the side of the SX5 module or on the shipping package. The network management is not completed successfully without the XIF extension.

8 Point Relay Output

SX5L-SBN16S

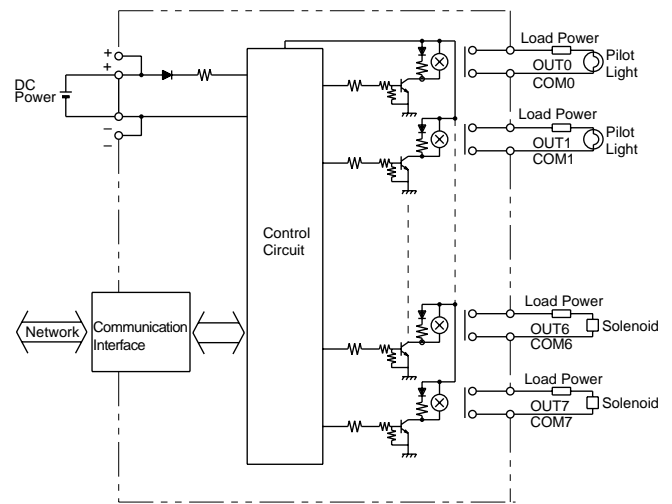

Reference Data

- ♦ Electrical Life Curve: Relay in SX5*-SBR08
- **Note 1:** AC/DC Resistive Load
- Operating frequency: 1800 operations/hour

AC Load

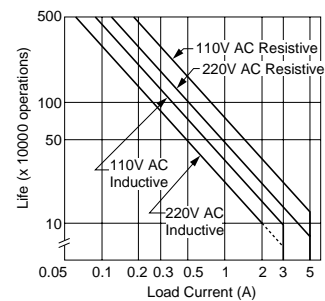

DC Load

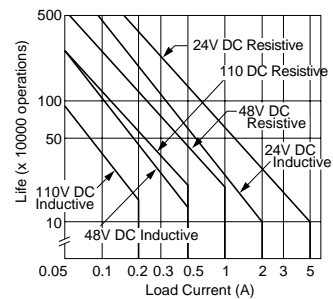

Duty ratio: 40%

- **Note 2:** AC Inductive Load

Line	Making Current	Breaking Current	Frequency	Duty Ratio
Solid	10 I, $\cos \theta = 0.7$	I, $\cos \theta = 0.3$ to 0.4	1800 operations/h	40%
Dashed	5 I, $\cos \theta = 0.7$	I, $\cos \theta = 0.3$ to 0.4	300 operations/h	

- **Note 3:** DC Inductive Load

Operating frequency: 1800 operations/hour
 Duty ratio: 40%
 Time constant: L/R = 15 msec

16 Point Transistor Output Modules (LonWorks)



Key features include:

- Communicate with LonWorks network
- Low cost 16 point transistor output module (sink/source)
- Easy and convenient detachable upper/lower terminal plugs
- The source output is protected against overload

Input Type	Source	Sink
Part Number	SX5L-SBT16K	SX5L-SBT16P

Transistor Output Type

Type No.	SX5L-SBT16K	SX5L-SBT16P
Output Type	Sink output	Protect source output
Output Points	16 points	
Output Type	N-channel MOS open drain	P-channel MOS open drain
Rated Load Voltage	24V DC	
Load Voltage Range	3 to 30V DC	19 to 30V DC
Maximum Load Current	0.5A/point	
Commons/Current	1 common/6A	
Short-circuit Protection	No	Yes
Current Draw	30 mA	60 mA

Terminal Arrangement

Upper Terminal Plug (SX9Z-SS1)		Lower Terminal Plug (SX9Z-SS2)	
Symbol	Signal	Symbol	Signal
+	COM (+)	+	POWER (+)
-	COM (-)	-	POWER (-)
0	OUT0	8	OUT8
1	OUT1	9	OUT9
2	OUT2	10	OUT10
3	OUT3	11	OUT11
4	OUT4	12	OUT12
5	OUT5	13	OUT13
6	OUT6	14	OUT14
7	OUT7	15	OUT15

J

Communication Cables

Bus	Network I/F Connector (on the module)	Cable
LonWorks	Phoenix Contact 2-pin connector MSTBV2.5/2-GF-5.08	Single twisted-pair cable AWG24 to 14 0.2 to 2.5 mm ²

Communication Speed and Distance

Bus	Baud Rate	Transmission Distance
LONWORKS	78 kbps	500m (total length) *2 400m (between nodes)

Communication Configuration

All SX5L Modules:

- The application program of the LonWorks is installed in the Neuron chip of the SX5L module.
- When wink is executed, the RUN LED flashes for 3 seconds in 500-msec increments.
- In the offline mode, the RUN and ERR LEDs go off and all outputs also go off.

SX5L-SBT16*:

- Output is updated only when input network variables are received. (At power-up to the network, all outputs remain off until initial communication starts.)

continued

Communication Configuration continued

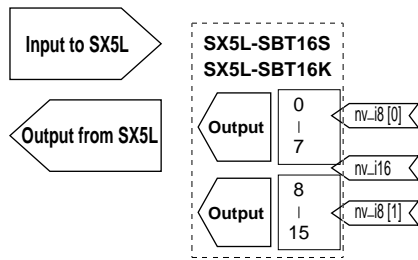

Wiring LONWORKS Cable

- Turn power off before wiring the SX5L to the LonWorks network. Make sure of correct wiring before turning power on. Supply power to each slave station or to each group of stations separately.
- The LONWORKS network uses a twisted-pair cable. The connector has no polarity and the core wires of the twisted-pair cable can be connected to either terminal of the connector.
- The LONWORKS network requires network management to enable communication between nodes, including the SX5L.
- The network management requires an XIF extension. For your XIF extension, find your XIF No., printed on the side of the SX5 module or on the shipping package. The network management is not completed successfully without the XIF extension.

16 Point Transistor Source Output

SX5L-SBN16S

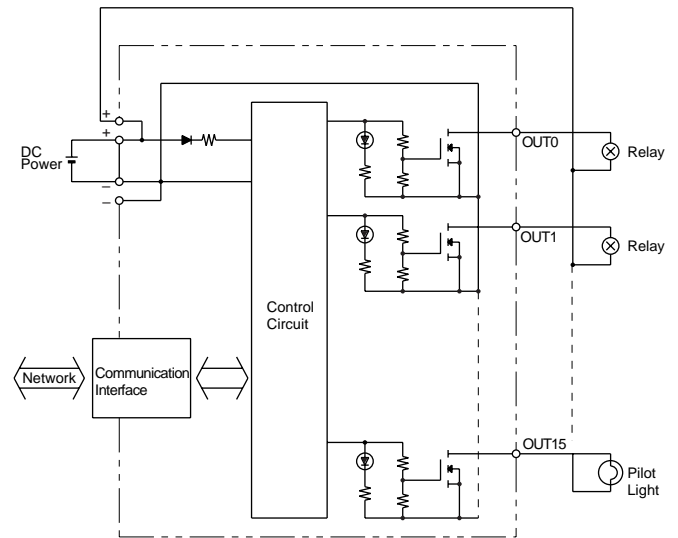

16 Point Transistor Sink Output

SX5L-SBN16K

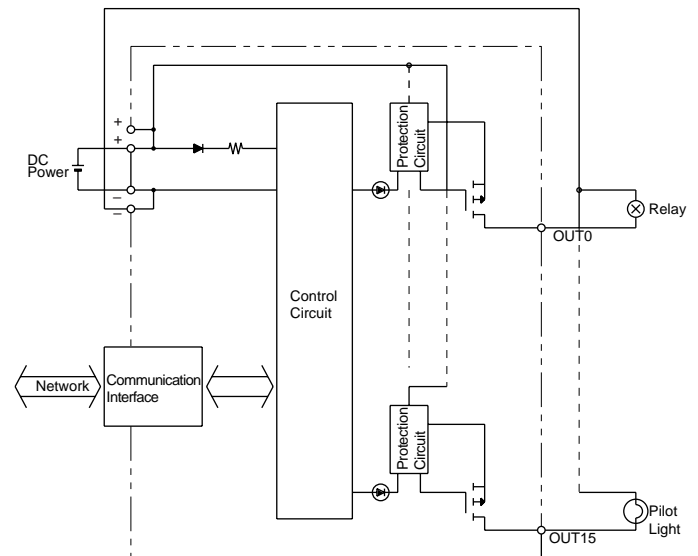

J

8 Point Source Input & 8 Point Transistor Sink Output Module (LonWorks)

Key features include:

- Communicate with LonWorks network
- Low cost 8 point source input and 8 point sink output module
- Easy and convenient detachable upper/lower terminal plugs

Input Type	Source Input/Sink Output
Part Number	SX5L-SBM16K

DC Input / Transistor Sink Output Type

Type No.	SX5L-SBM16K
I/O Type	Source input / sink output
Input	
Input Logic	Active Low
Input Points	8 points
Input Type	No-voltage input (2-wire DC sensor, 3-wire NPN sensor, no-voltage contact)
Rated Input Voltage	24V DC
Input Voltage Range	0 to the power voltage
ON Voltage	6V maximum
OFF Voltage	10V minimum
Input Current	7 mA/24V DC
Common	1 common
Output	
Output Points	8 points
Output Type	N-channel MOS open drain
Rated Load Voltage	24V DC
Load Voltage Range	3 to 30V DC
Maximum Load Current	0.5A/point
Commons/Current	1 common/4A
Short-circuit Protection	No
Current Draw	100 mA

Communication Cables

Bus	Network I/F Connector (on the module)	Cable
LonWorks	Phoenix Contact 2-pin connector MSTBV2.5/2-GF-5.08	Single twisted-pair cable AWG24 to 14 0.2 to 2.5 mm ²

Communication Speed and Distance

Bus	Baud Rate	Transmission Distance
LONWORKS	78 kbps	500m (total length) *2 400m (between nodes)

Terminal Arrangement

Upper Terminal Plug (SX9Z-SS1)		Lower Terminal Plug (SX9Z-SS3)	
Symbol	Signal	Symbol	Signal
+	COM (+)	+	POWER (+)
-	COM (-)	-	POWER (-)
0	IN0	0	OUT0
1	IN1	1	OUT1
2	IN2	2	OUT2
3	IN3	3	OUT3
4	IN4	4	OUT4
5	IN5	5	OUT5
6	IN6	6	OUT6
7	IN7	7	OUT7

J

Communication Configuration

All SX5L Modules:

- The application program of the LonWorks is installed in the Neuron chip of the SX5L module.
- When wink is executed, the RUN LED flashes for 3 seconds in 500-msec increments.
- In the offline mode, the RUN and ERR LEDs go off and all outputs also go off.

SX5L-SBM16* (inputs):

- Output network variables are updated only at the transition of the input status.
(When all inputs are off at power-up, network variables are not updated.)
- When nv_update_fails is TRUE(1) while using the data acknowledged service (ACKD), the ERR LED goes on.
- The ERR LED goes off when nv_update_succeeds is TRUE(1).
(When an attempt to send network variables fails, resending does not occur until the input changes status.)

continued

Communication Configuration Continued

SX5L-SBM16* (outputs):

- Output is updated only when input network variables are received.
(At power-up to the network, all outputs remain off until initial communication starts.)

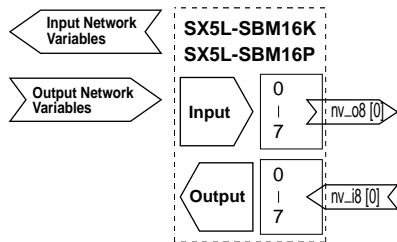

Wiring LONWORKS Cable

- Turn power off before wiring the SX5L to the LonWorks network. Make sure of correct wiring before turning power on. Supply power to each slave station or to each group of stations separately.
- The LONWORKS network uses a twisted-pair cable. The connector has no polarity and the core wires of the twisted-pair cable can be connected to either terminal of the connector.
- The LONWORKS network requires network management to enable communication between nodes, including the SX5L.
- The network management requires an XIF extension. For your XIF No., printed on the side of the SX5 module or on the shipping package. The network management is not completed successfully without the XIF extension.

8 Point Source Input

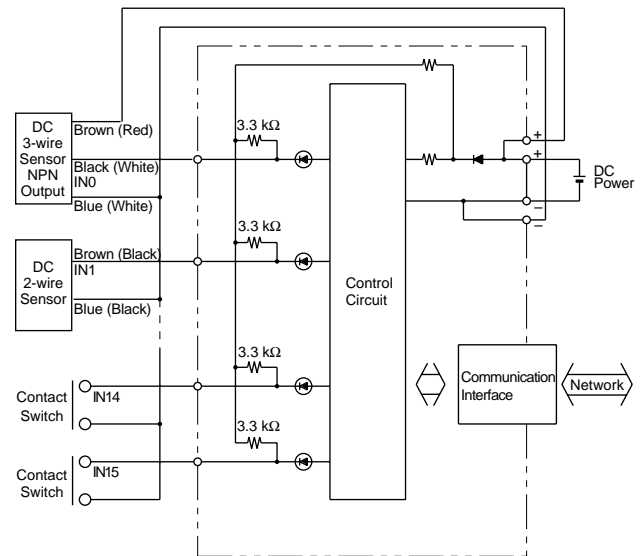

8 Point Transistor Sink Output

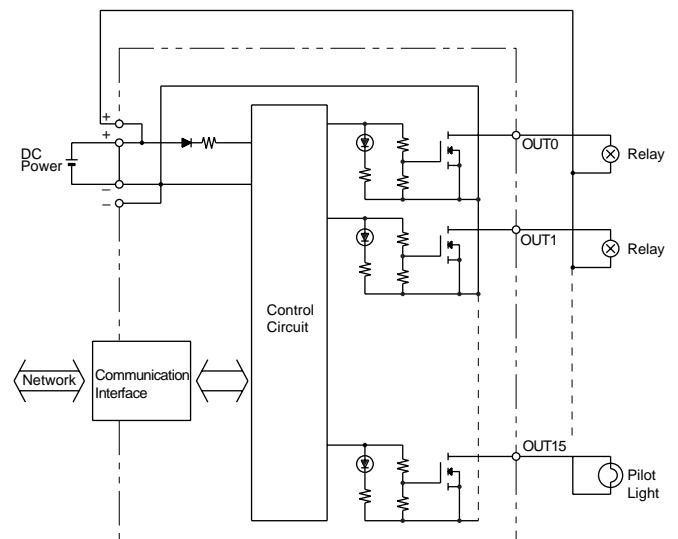

8 Point Sink Input & 8 Point Transistor Source Output Module (LonWorks)

Key features include:

- Communicate with LonWorks network
- Low cost 8 point sink input and 8 point source output module
- Easy and convenient detachable upper/lower terminal plugs

Input Type	Sink Input/Source Output
Part Number	SX5L-SBM16P

DC Input / Transistor Source Output Type

Type No.	SX5L-SBM16P
I/O Type	Sink input / protect source output
Input	
Input Logic	Active High
Input Points	8 points
Input Type	No-voltage input (2-wire DC sensor, 3-wire PNP sensor, no-voltage contact)
Rated Input Voltage	24V DC
Input Voltage Range	0 to the power voltage
ON Voltage	10V minimum
OFF Voltage	6V maximum
Input Current	6 mA/24V DC
Common	1 common
Output	
Output Points	8 points
Output Type	P-channel MOS open drain
Rated Load Voltage	24V DC
Load Voltage Range	19 to 30V DC
Maximum Load Current	0.5A/point
Commons/Current	1 common/4A
Short-circuit Protection	Yes
Current Draw	100 mA

Communication Cables

Bus	Network I/F Connector (on the module)	Cable
LonWorks	Phoenix Contact 2-pin connector MSTBV2.5/2-GF-5.08	Single twisted-pair cable AWG24 to 14 0.2 to 2.5 mm ²

Communication Speed and Distance

Bus	Baud Rate	Transmission Distance
LONWORKS	78 kbps	500m (total length) *2 400m (between nodes)

Terminal Arrangement

Upper Terminal Plug (SX9Z-SS1)		Lower Terminal Plug (SX9Z-SS3)	
Symbol	Signal	Symbol	Signal
+	COM (+)	+	POWER (+)
-	COM (-)	-	POWER (-)
0	IN0	0	OUT0
1	IN1	1	OUT1
2	IN2	2	OUT2
3	IN3	3	OUT3
4	IN4	4	OUT4
5	IN5	5	OUT5
6	IN6	6	OUT6
7	IN7	7	OUT7

J

Communication Configuration

All SX5L Modules:

- The application program of the LonWorks is installed in the Neuron chip of the SX5L module.
- When wink is executed, the RUN LED flashes for 3 seconds in 500-msec increments.
- In the offline mode, the RUN and ERR LEDs go off and all outputs also go off.

SX5L-SBM16* (inputs):

- Output network variables are updated only at the transition of the input status.
(When all inputs are off at power-up, network variables are not updated.)
- When nv_update_fails is TRUE(1) while using the data acknowledged service (ACKD), the ERR LED goes on.
- The ERR LED goes off when nv_update_succeeds is TRUE(1).
(When an attempt to send network variables fails, resending does not occur until the input changes status.)

continued

Communication Configuration Continued

SX5L-SBM16* (outputs):

- Output is updated only when input network variables are received.
(At power-up to the network, all outputs remain off until initial communication starts.)

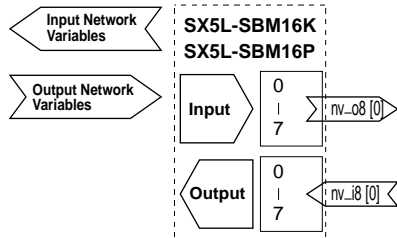

Wiring LONWORKS Cable

- Turn power off before wiring the SX5L to the LonWorks network. Make sure of correct wiring before turning power on. Supply power to each slave station or to each group of stations separately.
- The LONWORKS network uses a twisted-pair cable. The connector has no polarity and the core wires of the twisted-pair cable can be connected to either terminal of the connector.
- The LONWORKS network requires network management to enable communication between nodes, including the SX5L.
- The network management requires an XIF extension. For your XIF extension, find your XIF No., printed on the side of the SX5 module or on the shipping package. The network management is not completed successfully without the XIF extension.

8 Point Sink Input

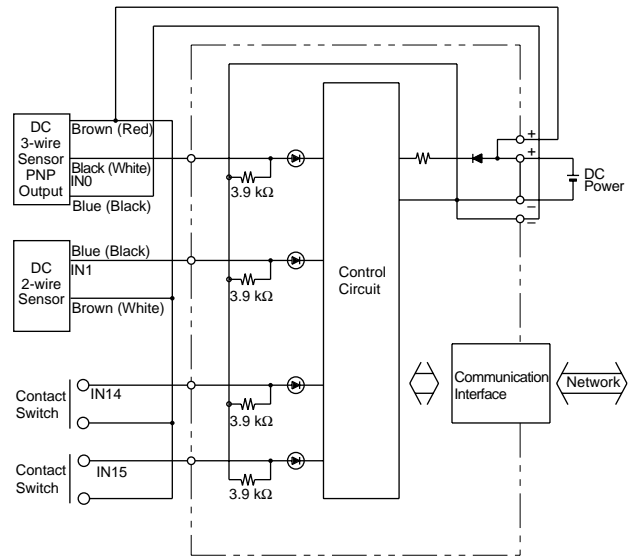

8 Point Transistor Source Output

