

SA1M: Analog Laser Color Mark Sensors

Using a visible red laser (670nm), the SA1M Laser Mark sensor is excellent for detecting label alignment and different kinds of objects. The small spot version can easily detect tiny objects. The parallel beam version keeps the detection spot size unchanged, regardless of the distance between the sensor and the object. Both versions ensure stable sensing without being influenced by changes in the sensing range and are ideal for use in varying environmental conditions.



Key features of the SA1M include:

- Stable output over a wide sensing range: 2.755" to 5.906" (70 to 150mm)
- Small visible beam enables detection of tiny objects (such as a spot) and thin materials
- High tolerance of fluctuating surface levels—ignores movement while sensing
- Insensitive to vertical movement of material to and from the sensor, as in the case of web flutter
- Ideal for use in industrial environments
- Dual analog output (light intensity and distance) and digital output
- IP65 protection rating

General Specifications	Power Voltage	24V DC (ripple 10% maximum)
	Current Draw	200mA maximum
	Light Source Element	Laser diode (670nm)
	Receiver Element	PSD (position sensitive device)
	Dielectric Strength	Between live and dead parts: 500V AC, 1 minute
	Insulation Resistance	Between live and dead parts: 20MΩ minimum (500V DC megger)
	Operating Temperature	0 to +45°C (performance will be adversely affected if the sensor becomes coated with ice)
	Storage Temperature	-20 to +70°C
	Operating Humidity	35 to 85% RH (avoid condensation)
	Vibration Resistance	Damage limits: 10 to 55Hz Single amplitude: 0.75mm 2 hours in each of 3 axes (de-energized)
	Shock Resistance	Damage limits: 100 m/s ² (approximately 10G) 5 times in each of 3 axes (when de-energized)
	Extraneous Light Immunity	Incandescent light, 3,000 lux maximum
	Operating Atmosphere	Free from corrosive gasses
	Material	Housing: Zinc diecast Coverplate: Polyarylate Filter: Glass
	Degree of Protection	IP65 IEC Pub 529
Cable	Cable type: 6-core vinyl cabtyre cable 0.19mm ² : 6' – 6-3/4' (2m) long	
Weight	Approximately 400g	
Dimensions (HxWxD)	1.97" x 0.83" x 3.07" (50 x 21 x 78mm)	

Part Numbers: SA1M Sensors

Part Number	Spot Type	Sensing Range	Digital Output	Analog Output for Light Intensity (color mark)	Analog Output for Sensing Distance
SA1M-CK4-AC	Small spot	2.755" to 5.906" (70mm to 150mm)	NPN open collector	4 to 20mA 5V maximum	20 to 4mA 5V maximum
SA1M-CK4-BC	Parallel beam		NPN open collector		
SA1M-CL4-AC	Small spot				
SA1M-CL4-BC	Parallel beam				

Function Specifications	Sensing Range	2.755" to 5.906" (70 to 150mm)
	Digital Output	Output style: NPN open collector: (SA1M-CK4-AC/BC) PNP open collector: (SA1M-CL4-AC/BC) with short circuit protection Output type: Window comparator output (in-window ON) Response time: 1ms maximum Hysteresis: 5% (0.8mA) maximum (over the entire sensing range) Applied voltage: 30V DC maximum Load current: 100mA maximum Voltage drop: 1.0V maximum (SA1M-CK4-AC/BC) 1.5V maximum (SA1M-CL4-AC/BC)
	Analog Output for Light Intensity (color mark detection)	Analog current output: 4 to 20mA, 5V maximum Reference output current (Note 1): 19.0+/-0.4mA Output stability (Note 2): ±5% (±0.8mA) maximum (against reference output current over the entire sensing range) Temperature drift (Note 3): ±5% (±0.8mA) maximum (against reference output current over the entire operating temperature) Response time: 1ms maximum (10 to 90% response) Additional noise (Note 2): 0.4mA maximum p-p (Position: 70mm)
	Auxiliary Output (Note 4) (analog output for distance)	Analog current output: 20 to 4mA, 5V maximum Linearity error (Note 2): ±1.5% FS (±1.2mm) (over the entire sensing range) Resolution (Note 2): 0.008" (200µm); Position: 70mm Temperature drift (Note 3): 5µA/°C maximum (against the entire operating temperature) Response time 1ms maximum (10 to 90% response)
	Sensitivity Selections	Selection using the sensitivity selector: L: Low (low sensitivity, 35% of standard sensitivity) M: Middle (Standard sensitivity) H: High (high sensitivity, 3.5 times standard sensitivity)
	Indicators	Analog output for light intensity: Red LED (10-dot level meter, Mode selector: RUN) Digital output setting monitor: Red LED (10-dot level meter, Mode selector: SET1, SET2) Digital output: Red LED (turns on when output is on) Laser diode emission: Green LED (turns on while laser is emitted), laser emits approximately 1 second after power-up
	Accessories	Adjusting screwdriver, resistor (249Ω), operating instructions, warning label, precaution label



Measuring conditions:

1. Temperature: 25°C, Object: White ceramic (0.6mm thickness), Sensitivity: Middle, Position: 110mm
2. Temperature: 25°C, Object: White ceramic (0.6mm thickness), Sensitivity: Middle
3. Object: White ceramic (0.6mm thickness), Sensitivity: Middle, Position: 110mm
4. Auxiliary output should be used only to monitor distance

Applications

Stable output response over a wide sensing range, detecting the presence of package markings

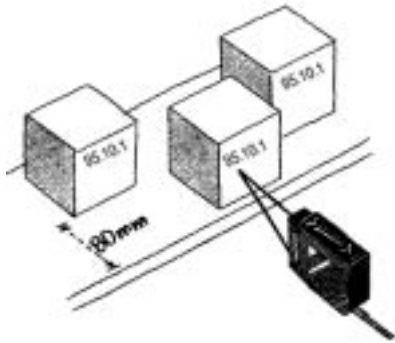

Long sensing distance (150mm maximum)

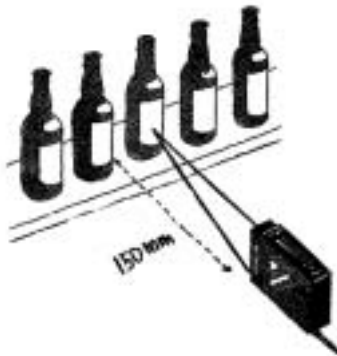

Counting the number of packages in a box

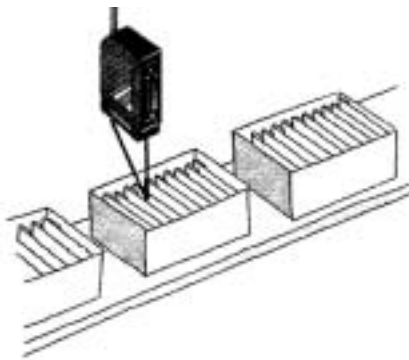

Small beam spot (0.5 x 1mm) (small spot type)

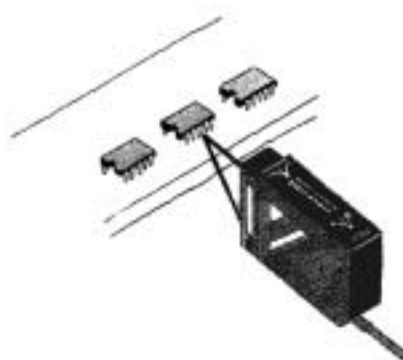

Compensating for fluctuating objects (parallel beam type) (±40mm)



Parallel beam type (beam size: 2 X 4mm)

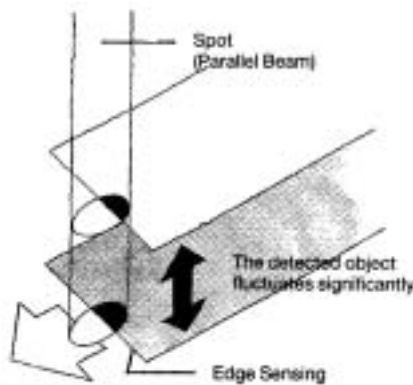

When the distance between the sensor and object varies significantly in positioning and edge sensing, the spot size remains unchanged, thus ensuring stable sensing.

When the output should not be influenced by blurs, taints, fine patterns, or lines in the object surface, stable sensing is ensured by the relatively large spot size.



Schematics

Connection Example (SA1M-CK4-AC/BC (NPN) Output)

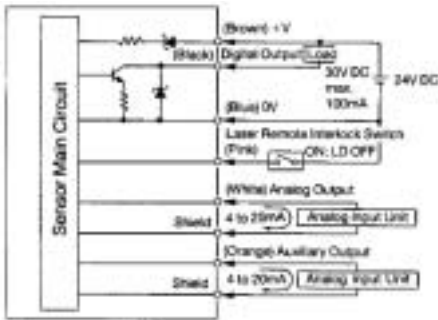

Connection Example (SA1M-CL4-AC/BC (PNP) Output)

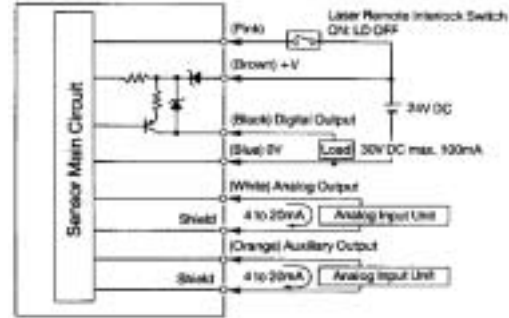

Auxiliary Output

Analog Output for Distance vs. Distance Characteristics

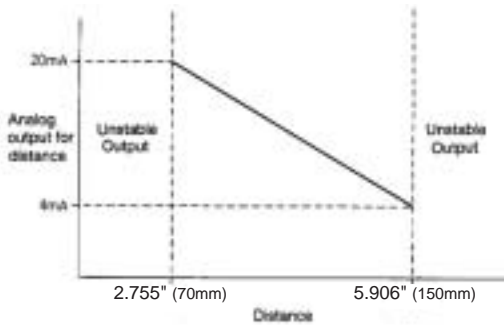

1. When the auxiliary output (analog output for distance) is used, the sensing distance should range from 70 to 150mm. If the sensing distance exceeds this range, an unstable output occurs.

Linearity Error for Auxiliary Output

Analog Output for Distance

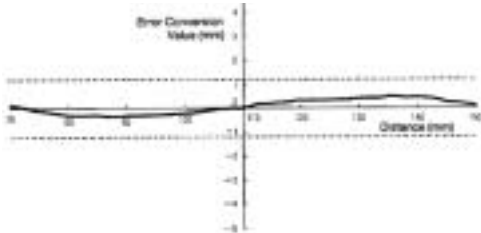

2. IDEC's laser displacement sensor is ideal when highly accurate distance measurement is required. (Sensing range is 60 to 160mm.) Refer to the MX1C section on page M-21.

Sensing Distance and Beam Distance

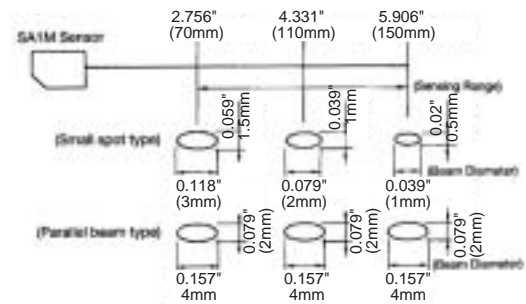

Dimensions

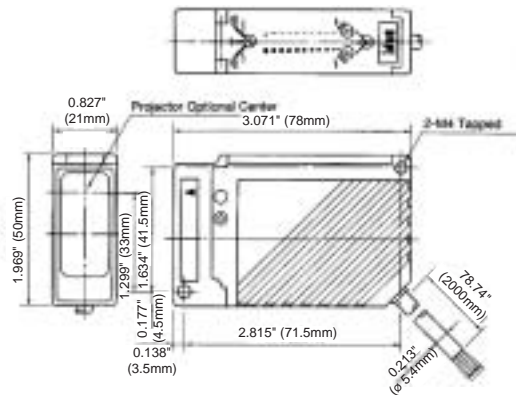

Laser Safety Information

Installation: If a sensor is installed so that the laser beam may shine or reflect into the eyes of a person passing by or working in the vicinity, place an opaque sheet of material in front of the beam to prevent potential eye injury. For people working near a laser sensor, protective glasses which screen out a significant amount of the harmful radiation are recommended at all times.

All SA1M laser sensors also include a remote interlock terminal which can be used to turn the laser on or off with an external switch, as required, to operate the sensor safely from a remote location. To avoid exposure to harmful radiation, never disassemble a laser sensor.

WARNING: Do not allow class IIIa beams to shine directly into the eyes. Do not allow lasers to reflect from a glossy, shiny, or reflective surface into the eyes.



Labelling: IDEC laser sensors include **CDRH-approved** safety warnings shown on the right and below, in compliance with federal regulations of the **Center for Devices and Radiological Health**.



SA1M Laser Mark Sensor:
Class IIIa Laser (670nm) Visible Beam



Warning Label (common)



All Laser Sensors:
Identification and Certification

mfd.: **FEBRUARY 1997**
Product conforms to
21 CFR1040

Precaution Label



SA1M Visible Laser:
Aperture Warning

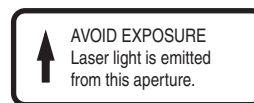

General Information

Specifications

Do not operate a sensor under any conditions exceeding these specifications.

Do not operate a sensor under current and voltage conditions other than those for which the individual sensor is rated.

Do not exceed the recommended operating temperature and humidity. Although sensors are rated for operation below 0°C, this specification does not imply that performance characteristics will remain constant under prolonged freezing conditions. Continued exposure and the accompanying frost, ice, dew, and condensation which accumulate on the optical surface will adversely affect sensor performance.

To maintain superior performance characteristics, do not exceed vibration and shock resistance ratings while operating a sensor. In addition, avoid isolated impacts to the sensor housing which are severe enough to adversely affect the waterproof characteristics.

IEC (International Electrotechnical Commission) Ratings

Sensors rated IP67 are resistant to moisture when occasionally immersed in still water. Sensors rated IP64 through IP66 are resistant to moisture when occasionally subjected to splashing or when located in the vicinity of turbulent waters. These ratings do not imply that a sensor is intended for use under continual high-pressure water spray. Avoid such applications to maintain optimal sensor performance.

Sensors rated IP64 through IP67 are dust-tight and water-tight. For best performance, avoid using any sensor in an area where it will be subjected to heavy particle blasts and where dust, water, or steam will accumulate on the optical surface.

Start-up

Do not test the housing for dielectric strength and insulation resistance, since the housing is connected to the electronic circuit ground of a sensor. Do not perform dielectric strength and insulation resistance tests on electrical systems without disconnecting photoelectric sensors, as such testing may result in damage to the sensor.

Several lines of sensors, as noted in the individual *operation* sections, are provided with an internal circuit to turn an output off for a specified amount of time upon power-up. This delay is normal; it prevents a transient state when turning power on.

Optimum Performance

The optical surface of each sensor must be cleaned on a regular basis for continual superior performance. Use a soft cloth dipped in isopropyl alcohol to remove dust and moisture build-up.

IMPORTANT: Do not use organic solvents (such as thinner, ammonia, caustic soda, or benzene) to clean any part of a sensor.

All sensors experience signal inconsistencies under the influence of inductive noise. Do not use sensors in close proximity to transformers, large inductive motors, or generators. Avoid using sensors in direct contact with sources of excessive heat. Also avoid operation in close proximity to welding equipment.



1. Even though the SA6A ultrasonic sensor features protection against noise, there may be adverse effects from strong noise.
2. It is strongly recommended to avoid using any sensor where it will be continually subjected to elements which impair performance or cause corrosive damage to the sensor. In particular, avoid strong vibrations and shocks, corrosive gases, oils, and chemicals, as well as blasts of water, steam, dust, or other particles.

Extraneous Light

Bright, extraneous light such as sunlight, incandescent lights, or fluorescent lights may impair the performance of sensors in detecting color or light.



3. SA6A ultrasonic sensors are not affected by extraneous light.

Make sure that extraneous light does not exceed recommended levels found in the individual *specifications* sections. When 500 lux is specified, this is equal to 50 footcandles. The average factory illumination is ordinarily below this level, except in areas where visual inspection is being performed. Only in such brightly lit areas is incident light of particular concern.

Unwanted light interference can often be avoided simply by making sure that the optical receiver is not aimed directly toward a strong light source. When mounting direction cannot be adjusted, place a light barrier between all nearby light sources and the receiver.

Reflected-Light Sensors

When installing sensors which detect reflected light, make sure that unwanted light reflections from nearby surfaces, such as the floor, walls, reflective machinery, or stainless steel, do not reach the optical receiver.

Also, make sure that reflected-light sensors mounted in close proximity do not cause interfering reflections. When it is not possible to maintain the recommended clearance between sensors, as noted in the individual *installation* sections, provide light barriers between sensors.

Through-Beam Sensors

A slit attachment is available to modify the beam size of through-beam sensors. This option is recommended for detecting very small objects (near the size of the smallest object which a sensor can detect) or for eliminating light interference when sensors are mounted in close proximity.

Laser Sensors

IMPORTANT: Always consider safety when installing a laser sensor of any kind. Make sure that the laser beam cannot inadvertently shine into the eyes of people passing by or working in the vicinity. See safety information on page Q-20.

Mounting

The mounting bracket and hardware are included with sensors, where applicable. Use the appropriate hardware for mounting, along with washers and spring washers or lock nuts. Do not overtighten attachment hardware. Overtightening causes damage to the housing and will adversely affect the waterproof characteristics of the sensor.

Best results can be obtained when the sensor is mounted so that the object sensed is in the center of the beam, rather than when the object is located near the edges of the sensing window. In addition, the most reliable sensing occurs when the majority of the objects being sensed are well within the sensing range, rather than at the extreme near and far limits.

Wiring

Avoid running high-voltages or power lines in the same conduit with sensor signal lines. This prevents inaccurate results or damage from induced noise. Use a separate conduit when the influence of power lines or electromagnetic equipment may occur, particularly when the distance of the wiring is extended.

IMPORTANT: Connect the sensor cables and wires as noted in the individual *Wiring* sections. Failure to connect as shown in wiring diagrams will result in damage to the internal circuit.

When extending sensor cables and wires, make sure to use cables equal or superior to that recommended in the individual *specifications* sections.

When wiring terminals, be sure to prevent contact between adjoining terminals. When using ring or fork lug terminals, use the insulated sleeve style only. Each sensor terminal can accept only one ring of fork lug terminal.

On ISF series photoelectric sensors, use recommended cable, along with the attached packing gland and washer, when wiring the terminals. This ensures waterproof and dustproof characteristics.

Power Supply

Noise resistance characteristics are improved when a sensor is grounded to the 0V power terminal. If the 0V power terminal is not at ground potential, use a ceramic 0.01µF capacitor which can withstand 250V AC minimum.

When using a switching power supply, be sure to ground the FG terminal to eliminate high-frequency noise. The power supply should include an insulating transformer, not an autotransformer.

On ISF series photoelectric sensors, the power supply should be sized according to the voltage drop through the lead wire when using a long extension for the DC type (328' or 100m maximum extension).

Power Supply

The compact PS5R-A power supply is the perfect companion item for most IDEC sensors. This power supply is only 1.77" (45mm) wide, 3.15" (80mm) tall, and 2.76" (70mm) deep. Call an IDEC representative for more details.

Part Number	Output Ratings
PS5R-A12	12V DC, 0.62A
PS5R-A24	24V DC, 0.32A

Miscellaneous

Strong magnetic fields may detract from the accuracy of the sensing measurement. Avoid mounting a sensor directly to machinery, since the housing is connected to the electronic circuit ground of the sensor. If it is necessary to mount a sensor on machinery, use the insulating plate and sleeve provided.

Glossary

Attenuation: Reduction of beam intensity as a result of environmental factors such as dust, humidity, steam, etc.

Dark on: Output energized when light is *not* detected by the receiving element. For through-beam sensors, light from the projector is not detected by the receiver when an object is present. For reflected light sensors, light is not detected when it is not reflected from an object surface.

Diffuse-reflected light sensors: Sensors that detect all scattered, reflected light. Light reflected from nearby surfaces, as well as intended object surface, is detected. Diffuse-reflected light sensors are often called "proximity switches," since they switch when any object is near. Also use to detect color contrast when colors reflect light intensity differently (green LED recommended for this application).

EEPROM: Acronym which stands for electronically erasable, programmable, read only memory.

Excess gain: Ratio of optical power available at a given projector-to-receiver range divided by the minimum optical power required to trigger the receiver.

Extraneous light: Incident light received by a sensor, unrelated to the presence or absence of object being detected. Extraneous light is usually unwanted background light such as sunlight and incandescent lamps in close proximity.

ΔE: The measurement of color difference as a three-variable function, located on an XYZ axis of light, hue, and chroma values.

Hysteresis: Operating point and release point at different levels. For solid state sensors, this is accomplished electrically. For mechanical switches, it results from storing potential energy before the transition occurs.

Light on: Output energized when light is detected by receiving element. For through-beam sensors, light from the projector is detected by the receiver when an object is not present. For reflected light sensors, light is detected when it is reflected from an object surface.

Linearity: Measurement of how nearly linear, that is, how accurate actual analog output is, with respect to distance.

NPN/PNP: Types of open collector transistors. NPN is a sink transistor; output on establishes negative potential difference. PNP is a source transistor; output on establishes positive potential difference.

Polarizing: Filtering out all reflected light except that which is projected in one plane only. Polarized retro-reflected light sensors detect the light from corner-cube type reflectors when an object is not present.

Reflected-light sensors: Sensors with the projector and receiver in one housing. Light is projected by the light source, and reflected light is received by the optical surface. Includes diffuse-reflected, retro-reflected, limited-reflected, and spot-reflected sensors.

Repeatability: Ability of a sensor to reproduce output readings consistently when the same value is applied consecutively, in the same direction, for a specified number of cycles, or for a specified time duration.

Resolution: Overall dimension of the smallest object which can be detected (when sensing the presence of an object) or smallest increment of distance which can be distinguished with reliable results (when sensing the position of an object).

Response time: Time elapsed between input and output. Total response time is the sum of object detection, amplifier response, and output response times.

Retro-reflective scan: This type of reflected light sensor uses a special reflector to return projected light when an object is not present. Sensor detects the presence of an object when the light is reflected differently.

Through-beam sensors: Sensors with a separate projector and receiver. The light source from the projector is detected by the receiver, except when an object is present.

Transient: Undesirable surge of current (many times larger than normal current) for a very short period, such as during the start-up of an inductive motor.