

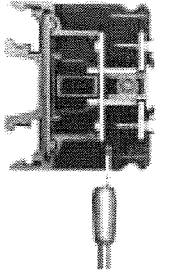
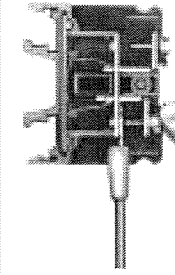
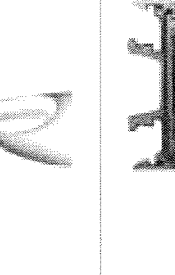
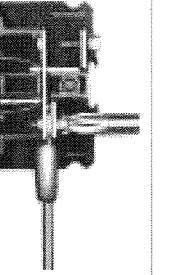
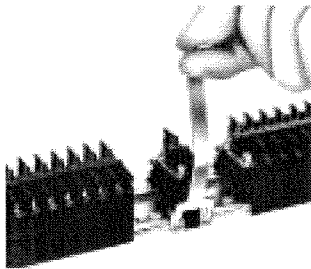

## Instructions

### Wiring Touch-Down Terminal Blocks: BNH Series

Instructions	Step 1	Step 2	Step 3	Step 4
Step 1. Insert the wire (or crimping terminal) into the terminal block with the terminal screws in the open position. (Use of crimping terminals is optional.)				
Step 2. Push the terminal screw down to hold the wire in place.				
Step 3. Hold the terminal screw down, and tighten with a screwdriver.				
Step 4. To remove the wire, loosen the terminal screw and pull up until wire is released.				

### Installation and Removal of Terminal Blocks

Instructions	Appearance
<p>Step 1. Slide the terminal blocks onto the DIN rail from one end.</p> <p>Step 2. Use BNL5 or BNL6 end clips to secure the terminal block row and to prevent side-to-side movement. BNH10W, BNH15MW, BNH15LW, and BNH30W can be installed from the middle of a DIN rail.</p> <p>Step 3. To install, place the terminal block on top of the DIN rail and push down until both edges of the terminal block snap onto the DIN rail.</p> <p>Step 4. To remove the terminal block, use the BND2 removal tool as shown on the right.</p>	 <p><b>Removal Tool BND2</b></p> 

### Mounting Double-Deck Terminal Blocks

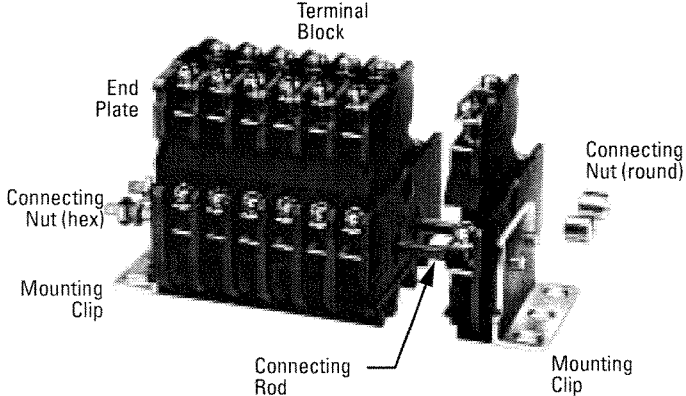
Instructions	Appearance
<p><b>DIN Rail Mount:</b></p> <p>Step 1. First install the end plate. Then mount the terminal blocks onto the DIN rail.</p> <p>Step 2. To prevent side-to-side movement on the DIN rail, use the BNL-8 mounting clip at both ends of the rail.</p>	
<p><b>Panel Mount:</b></p> <p>Step 1. Assemble a row of terminal blocks with end plates on exposed end(s).</p> <p>Step 2. Use BNDL2 mounting clips at both ends of a row.</p> <p>Step 3. With the two holes of the mounting clip aligned with the terminal block holes, insert a connecting rod through each hole.</p> <p>Step 4. Secure the ends of the connecting rods with the connecting nuts, as shown below.</p>	

**Calculating DIN Rail Lengths**

Instructions	Appearance
<p>Step 1. Add widths of all terminal blocks (reference pages K-4 through K-9).</p> <p>Step 2. Add the endplate thickness (usually only one).</p> <p>Step 3. Add the DIN rail stop widths (usually two are used).</p> <p>Step 4. Round to the nearest 2" (50mm) increment to allow for DIN rail hole spacing.</p> <p>Step 5. Add 1" (25mm) to ensure 0.5" (12.5mm) of clearance at each end of the DIN rail.</p>	

**DIN Rail Stop Dimensions**

Part No.	Width
BNL-5	.374" (9.5mm)
BNL-6	.374" (9.5mm)
BNL-8	.571" (14.5mm)

**Torque Specifications**

Screw Size	M3	M3.5	M4	M5	M6	M8	M10	M12	Diagram
<b>Torque</b>	(N-m) 0.6 to 1.0	1.0 to 1.3	1.4 to 2.0	2.6 to 3.7	3.9 to 5.4	10 to 13.5	21 to 28	38 to 49	
	(kgf-cm) 6.1 to 10.2	10.2 to 13.3	14.3 to 20.4	26.5 to 37.7	39.8 to 55.1	102 to 138	214 to 286	388 to 500	
<b>Dimension A</b>	0.257" (6.6mm)	0.332" (8.5mm)	0.371" (9.5mm)	0.499" (12.8mm)	0.655" (16.8mm)	0.890" (22.8mm)	1.279" (32.8mm)	1.981" (50.8mm)	
<b>Dimension B</b>	0.129" (3.3mm)	0.156" (4mm)	0.176" (4.5mm)	0.176" (4.5mm)	0.234" (6mm)	0.312" (8mm)	0.429" (11mm)	0.546" (14mm)	
<b>Dimension C</b>	0.195" (5mm)	0.195" (5mm)	0.234" (6mm)	0.254" (6.5mm)	0.332" (8.5mm)	0.429" (11mm)	0.624" (16mm)	1.014" (26mm)	
<b>Dimension D</b>	Ø 0.125" (3.2mm)	Ø 0.140" (3.6mm)	Ø 0.164" (4.2mm)	Ø 0.203" (5.2mm)	Ø 0.242" (6.2mm)	Ø 0.332" (8.5mm)	Ø 0.410" (10.5mm)	Ø 0.488" (12.5mm)	

**Rated Current**

Applicable Wire	Rated at 60°C
22 AWG (0.3mm <sup>2</sup> )	3A
20 AWG (0.5mm <sup>2</sup> )	5A
18 AWG (0.75mm <sup>2</sup> )	7A
16 AWG (1.25mm <sup>2</sup> )	10A
14 AWG (2mm <sup>2</sup> )	15A
12 (3.5mm <sup>2</sup> )	20A
10 (5.5mm <sup>2</sup> )	30A
6 (14mm <sup>2</sup> )	50A
4 (22mm <sup>2</sup> )	75A
0 (38mm <sup>2</sup> )	100A
00 (60mm <sup>2</sup> )	150A
0000 (100mm <sup>2</sup> )	200A
300mcm (150mm <sup>2</sup> )	300A
400mcm (200mm <sup>2</sup> )	350A

*UL/CSA ratings are specified. The current carrying capacity depends on the rating of the wire used, as shown.*

