



S62...M Background suppression

INSTRUCTION MANUAL

CONTROLS

OUTPUT LED (yellow)

The yellow LED ON indicates that the N.O. output is closed and the N.C. output is open.

STABILITY LED (green)

When permanently ON, the green LED indicates a normal operating condition where the received signal has a safety margin superior to 30% respect to the output switching value. The sensor is ready to function correctly (stability condition).

DISTANCE ADJUSTMENT TRIMMER (ADJ.)

A 6-turn trimmer allows the background suppression distance adjustment through a mechanical variation of the optic triangulation angle. The operating distance increases, rotating the screws in a clockwise direction. Please refer to the "SETTING" paragraph for acquisition or setup procedure indications.

POSITION INDICATOR

This indicator presents a scale numbered from 1 to 6 that allows a precise adjustment of the suppression distance in the entire operating range. Please refer to the "SETTING" paragraph for use indications.

TIMER ADJUSTMENT TRIMMER (only M05/M15/M25/M35 vers.)

This control allows to vary the output delay deactivation from 0 to 1 sec. Please refer to "TIMER FUNCTIONS" paragraph for use indications.

INSTALLATION

The sensor can be positioned by means of the three housing's holes using two screws (M4x25 or longer, 1.5Nm max. tightening torque) with washers.

Various orientable fixing brackets to ease the sensor positioning are available (please refer to the general catalogue).

The operating distance is measured from the front surface of the sensor optics.

The M12 connector can be oriented at two different positions using the specific fastening spring and rotating the block of 180°.



CONNECTIONS

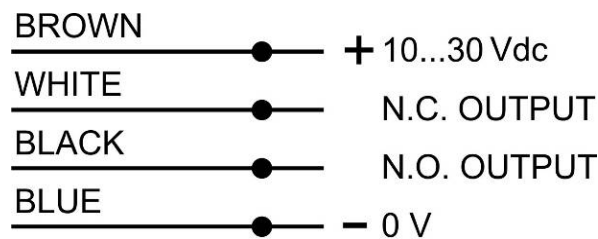

M12 connector

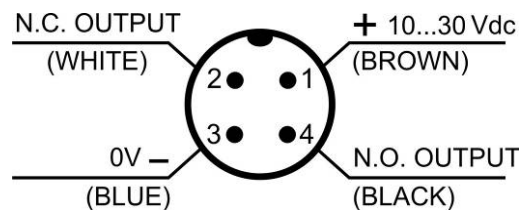

TECHNICAL DATA

	S62-M0...	S62-M1...	S62-M2...	S62-M3...
Power supply:	10 ... 30 VDC			
Ripple:	2 Vpp max.			
Consumption (output current excluded):	40 mA max.			
Outputs:	PNP or NPN N.O./N.C.; 30 Vdc max. (short-circuit protection)			
Output current:	100 mA (overload and overvoltage protection)			
Output saturation voltage:	≤ 2 V			
Response time:	500 μs	1 ms	1 ms	1,5 ms
Switching frequency:	1 kHz	500 Hz	500 Hz	330 Hz
Emission type:	RED (660 nm)	INFRARED (880 nm)		
Spot dimension:	6x6 mm (at 200 mm)	15x15 mm (at 400 mm)	200x200 mm (at 2000 mm) <i>(recommended target 400x400mm)</i>	
Operating distance (typical values):	30...300 mm	60...600 mm	60...1200 mm	200...2000 mm <i>(recommended target 400x400mm)</i>
Adjustment:	Multiturn distance adjustment trimmer / Timer adjustment trimmer (only M05/M15/M25/M35 vers.)			
Difference (90% white / 4% black):	< 8 %	< 12 %	< 25 %	< 30 %
Hysteresis (90% white):	< 5 %			
Indicators:	OUTPUT LED (YELLOW) / STABILITY LED (GREEN)			
Operating temperature:	-10 ... 55 °C			
Storage temperature:	-20 ... 70 °C			
Insulating strength:	500 Vac 1 min., between electronics and housing			
Insulating resistance:	>20 MΩ 500 Vdc, between electronics and housing			
Ambient light rejection:	According to EN 60947-5-2			
Vibrations:	0.5 mm amplitude, 10 ... 55 Hz frequency, for each axis (EN60068-2-6)			
Shock resistance:	11 ms (30 G) 6 shock for each axis (EN60068-2-27)			
Housing material:	ABS			
Lens material:	PMMA window; PC lens			
Mechanical protection:	IP67			
Connections:	2 m cable Ø 4 mm / M12-4 pole connector			
Weight:	90 g. max. cable vers. / 40 g. max. connector vers.			

SETTING

Suppression distance setting

1. Object detection

Position object to detect in front of the sensor at the distance required. Turn distance adjustment trimmer (ADJ) to minimum: yellow LED OFF and green LED ON.



Rotate trimmer in a clockwise direction until the yellow LED and green LED turn ON. *Object detection condition* (A status of position indicator)



A

2. Background suppression

Remove object and ensure that the background is in front of the sensor: yellow LED OFF and green LED ON.



Rotate trimmer in a clockwise direction until the yellow LED and green LED turn ON: *background detection condition* (B status of position indicator).

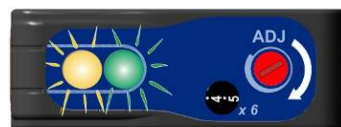

B

The trimmer reaches maximum level with yellow LED OFF if the background is outside the operating range.

Rotate trimmer in an anticlockwise direction until yellow LED turns OFF and green LED ON: *condition where background is outside operating range* (C status of position indicator).



C

3. Setting and control

Rotate trimmer in an anticlockwise direction until the indicator reaches an intermediate point between position A and C.



If position A and C are close to each other, leave trimmer on position C. The sensor is now ready to function correctly and in stable conditions:



DIAGRAMMA DI RILEVAZIONE



DIMENSIONS

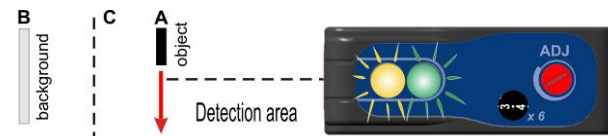
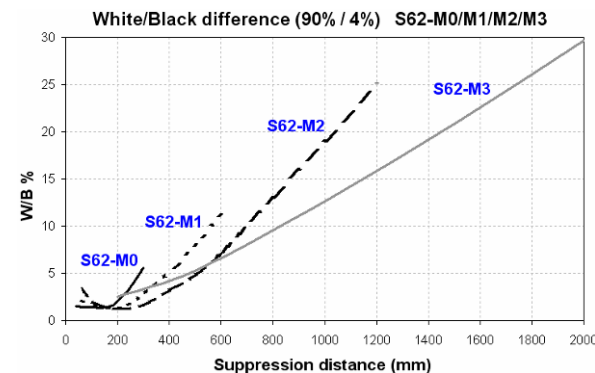
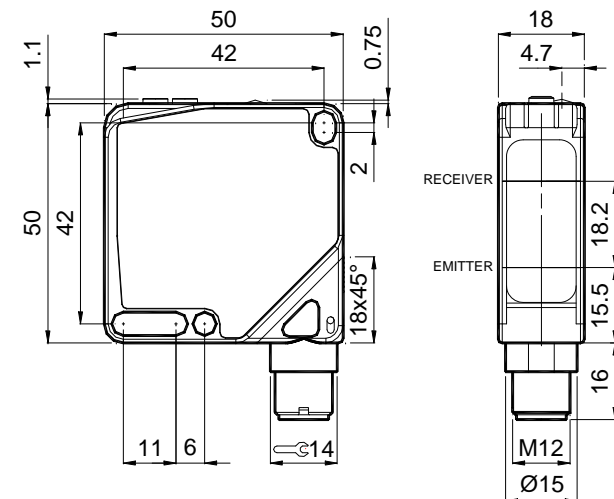

CABLE VERSION

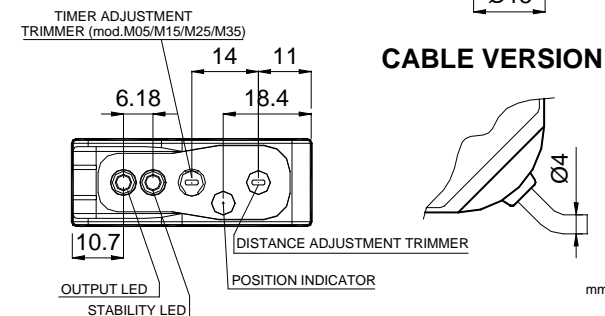

TIMER FUNCTION (S62...M05/M15/M25)

The timer function allows to adjust the output deactivation delay when the object is outside the detection area. The delay extends the output activation allowing the slower interface systems to detect shorter pulses.

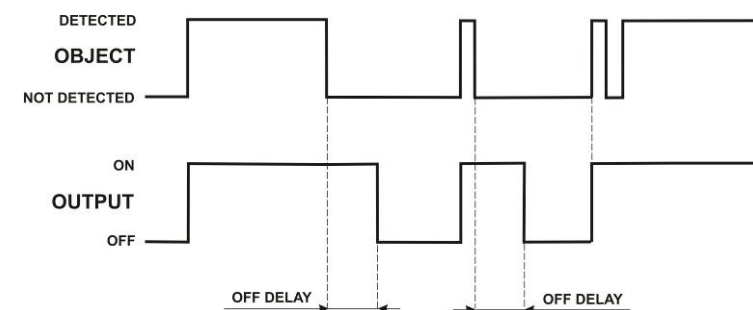

The delay adjustment is carried-out manually using the Timer adjustment trimmer. Clockwise rotation increase the delay from 0 to a max. 1 sec. value.



	EX-II-3-D T6	
	Temperature class:	T6 (<85°C)
	Max. Power consumption:	1260 mW at 30 Vdc
	Max. Internal capacitance:	130 nF
	Internal inductance:	negligible

www.idec-ds.com
800-262-4332

DECLARATION OF CONFORMITY
IDEC and DATASENSOR jointly declare under their sole responsibility that these products conform to the 2004/108/CE, 2006/95/CE Directives, and successive amendments.

IDEC and DATASENSOR reserve the right to make modifications and improvements without prior notification.