

Model LT7

Thank you for choosing the IDEC Signalight Tower for your application. Please read these instructions carefully before you perform installation, maintenance or repair. Keep this manual handy for easy reference. If you have any questions about this product, please contact IDEC at 1-800-262-IDEC (4332).

## 1. Safe Product Operation

### NOTES TO BE OBSERVED FOR SAFE OPERATION

Notes to be followed to prevent any damage to the user and other personnel or to assets are as follows:

- The indications for warning are divided into the following classes according to the degree of danger or damage incurred when the warning is not taken into consideration and the product is not currently used.

<b>Warning</b>	Indicates an imminently dangerous condition: failure to follow the instructions may lead to death or serious injury.
<b>Caution</b>	Indicates a potentially dangerous condition: failure to follow the instructions may lead to slight injury or property damage.

**Warning**

- Make sure the power is OFF before wiring. Incorrect wiring may result in a short circuit or electric shock.
- Make sure the power is OFF to avoid an electric shock or burn when repairing or replacing parts.
- Do not use this product with damaged lens or leave it without the lens or top cover. That may cause an electric shock.
- If installing this product requires construction work, please contact a specialist in order to avoid the risk of an electric shock, fire or injury.
- When this product is used for security purposes, it should be inspected daily. In case a malfunction should occur, it is recommended that you use this product together with other security products.
- Be careful not to hold on to the product to climb any machinery that might be attached to the product.

**Caution**

- Concerning replacement parts, such as LED unit or fuse, be sure to use those specified in this manual.
- For safety, make sure to connect an external fuse to the power source as shown in the wiring example.
- Do not substitute parts from other products. It may cause a breakdown.

## 2. Part Number Configuration

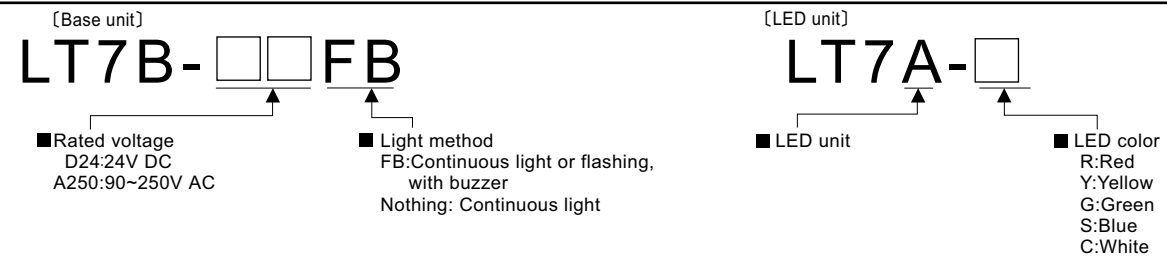

## 3. Component Names and Dimensions

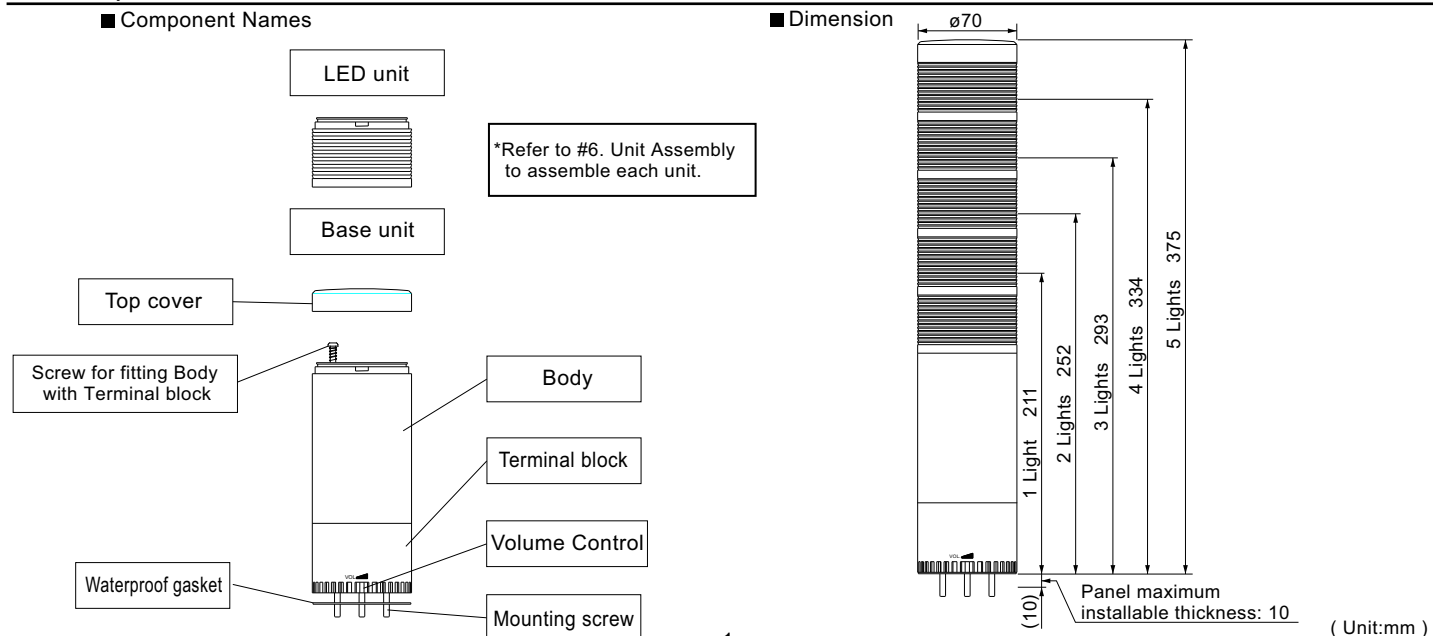

For more information contact IDEC Corporation  
 1175 Elko Drive • Sunnyvale, CA 94089  
 800-262-IDEC • fax: 408-745-5258

www.idec.com  
 email: support@idec.com

Smart Products. Simple Solutions.

## 6. Unit Assembly

- Turn the power OFF before performing unit assembly.
- First make sure the O-ring is mounted as shown in Drawing 1, then align the locating mark of each unit, and place the units together in the direction of the arrow (①) as shown.
- Rotate the upper unit in the direction of the arrow (②). (Refer to Drawing.2)
- For 90-250V type Base Unit, tighten the Screw that secures the Body to the Terminal block.

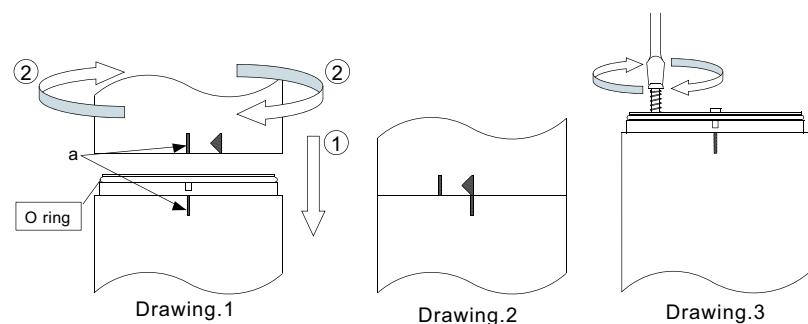

### Caution

- Do not use excessive force to remove or install the LED unit. It may damage the unit.
- Do not bend or damage the LED unit.
- Make sure the O-ring is first mounted in position as shown in Drawing 1, then place the Body on the O-ring.
- If the Body is mounted to the Terminal block, do not attempt to rotate either part with the Screw pushed in or engaged.
- Never attempt to tighten the Screw until the locating mark is aligned with the arrow as shown in Drawing 2.

## 7. Volume Adjustment

- You can adjust the volume by turning the volume control at the bottom to the left or right.

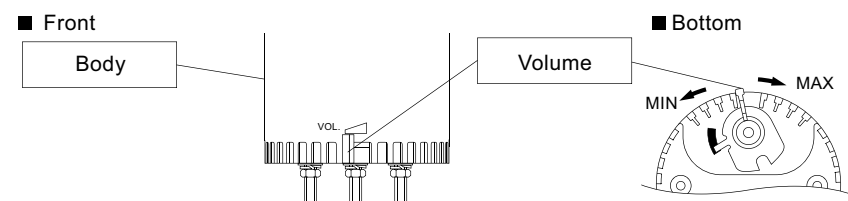

### Caution

- Do not use excessive force to turn the volume control. It might damage the volume control.

## 8. CE Marking Compliance

- Please use a fuse specified by IEC 127.
- When lead wires are exposed outside the body during pole installation, etc. always provide double insulation using insulation tape and vinyl tubing.
- For the 90-250V type, use shielded cable for the power supply cable and be sure to connect the shield to ground (CN5).

## 9. Specifications

### [Base Unit]

Model	Rated voltage	Power consumption	Weight	Flashing cycle and Peak sound level
LT7B-D24	24V DC	—	250g	FB Model 60 Flashes per minute
LT7B-D24FB		1.2W	275g	
LT7B-A250	90~250V AC (50/60Hz)	Buzzer: 2.2W Standby power consumption: 1.0W	350g	Sound level 70~90dB/m
LT7B-A250FB			375g	

### [LED Unit]

Model	Rated voltage	Power consumption	Weight
LT7A-R	24V DC	1.3W	60g
LT7A-Y			
LT7A-G	24V DC	1.0W	60g
LT7A-S			
LT7A-C			

### [Vibration resistance]

Number of LED units	1-Lights		2-Lights		3-Lights		4-Lights		5-Lights	
	4.5G	44.1m/s <sup>2</sup>	3.5G	34.2m/s <sup>2</sup>	2.0G	19.6m/s <sup>2</sup>	1.3G	12.7m/s <sup>2</sup>	0.7G	6.8m/s <sup>2</sup>
LTB-D24	4.5G	44.1m/s <sup>2</sup>	3.5G	34.2m/s <sup>2</sup>	2.0G	19.6m/s <sup>2</sup>	1.3G	12.7m/s <sup>2</sup>	0.7G	6.8m/s <sup>2</sup>
LTB-A250	4.5G	44.1m/s <sup>2</sup>	4.5G	44.1m/s <sup>2</sup>	1.9G	18.6m/s <sup>2</sup>	1.9G	44.1m/s <sup>2</sup>	1.0G	9.8m/s <sup>2</sup>
Allowable vibration frequency	10-150Hz									40-150Hz

### Caution

- In the event that the tower is subject to continuous, excessive shaking, vibration may be too strong and there is a danger of breakage. Immediately stop using the tower and consult IDEC Corporation.
- IDEC disclaims all liability for any malfunction or damage occurring as a result of handling contrary to the instructions, cautions and warnings mentioned in this manual.
- Specifications are subject to change without notice due to continual product improvement.

## 4. Installation

### ■ Mounting

- Drill mounting holes. (See the following installation diagram.)
- Secure the mounting bracket with the hex bolts and hex nuts.
- Install the Signallight Tower vertically at a location that has sufficient strength and minimal vibration.
- The alarm of the buzzer models can be heard best from the front. Therefore make sure the Signallight Tower is facing the correct direction before installation.

### Caution

- This product can be used only indoors. (Do not use it outdoors.)
- Do not install the Signallight Tower horizontally or inverted. (See the following "Mounting Orientation".)
- Make sure of the specified operating voltage and current before use.
- Do not use or keep without LED unit or top cover installed.
- Use a soft cloth with water when the LED unit or Base unit must be cleaned. (Do not use thinner, benzine, gasoline or oil.)
- During installation, do not remove the waterproof gasket. It may cause a malfunction of the water proof structure.
- This product has 1mm thick waterproof gasket at the bottom of the pole bracket. However, when complete waterproofing is not provided due to the unevenness of the installation surface, apply waterproof sealant between the unit and the installation surface to maintain waterproof conditions.

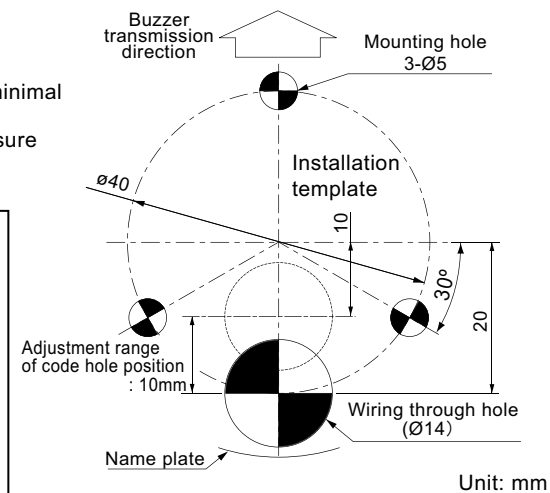

### Using this template

1. Confirm the hole position on the product.
  2. Secure the template to the installation surface using adhesive tape.
  3. Mark the installation holes using nail punch, etc.
  4. Drill the holes in the installation surface.
- \* Confirm the direction of the name plate and the wiring route before you drill the holes.

### Mounting Orientation

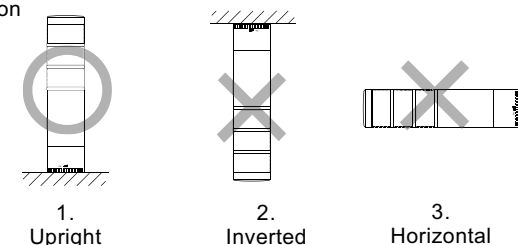

## 5. Wiring Procedure

### ■ Wiring Procedure

- When wiring 5 LED units or less, please make the wiring connection by increasing or decreasing external contacts to each unit according to wiring example.
- When using multiple LED units of the same color, make the contact capacity equal to the number of same color LED units multiplied by the contact capacity for 1 light. (This is because LED units of the same color light up for one signal line.)
- \* Fuse for protection of external contact should be installed within 305mm from the connected point of the power source wire.
- When wiring is complete, insulate the end of each unused lead wire by using insulation tape.
- \* Use "Class II Circuit" for the power supply. Concerning fuse and fuse-holder, use products authorized by UL Inc.
- \* Use a fuse conforming to the rated current of the machine. (Example: Class J type fuse.)
- \* For the 90~250V AC model, connect the green/yellow lead wire to ground.
- If you have any questions about simultaneous use of multiple units or other special operations, contact IDEC Technical Support before wiring.

### 5-1. Wiring Example for Base Unit (Terminal block)

- Remove Body from Base unit. (In case of 24V model, refer to "6. Unit Assembly".)
- Remove Body from Base unit. (In case of 90~250V model, refer to "5-1-2. Wiring Procedure for 90~250V Model".)

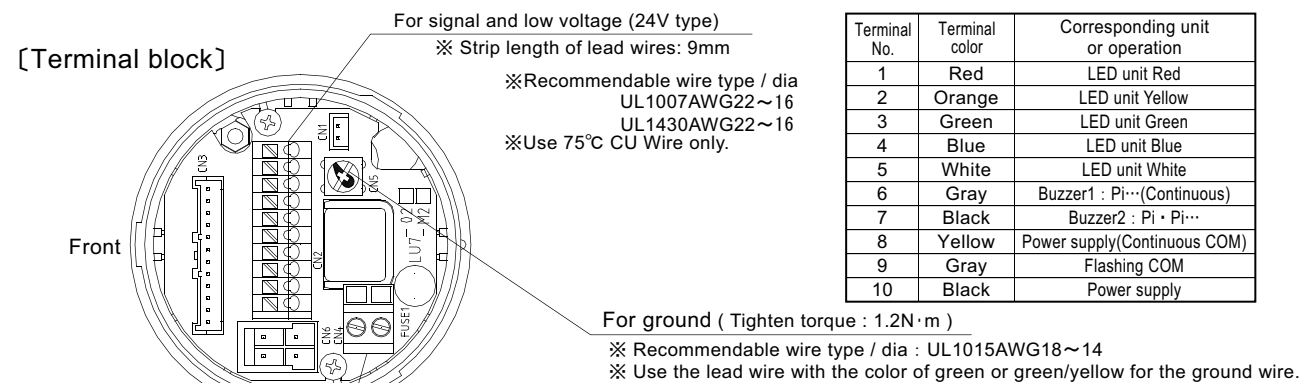

### Caution

- Never fail to observe the strip length of lead wire. Excessively short strip length causes connection failure and excessively long strip length gives rise to electric shock or short circuit, which are extremely dangerous.
- While wiring this product, take care to avoid short-circuits from loose wire strands or similar conditions.
- Do not use unnecessarily strong force to separate the Terminal block and the Body. Inside wiring may be damaged and may cause failure.
- Connect high-voltage power supply cable to the specified terminals in the Terminal block. Failure to connect this cable correctly will burn out the internal circuit.

### 5-1-1. Wiring Procedure for a Terminal (CN2)

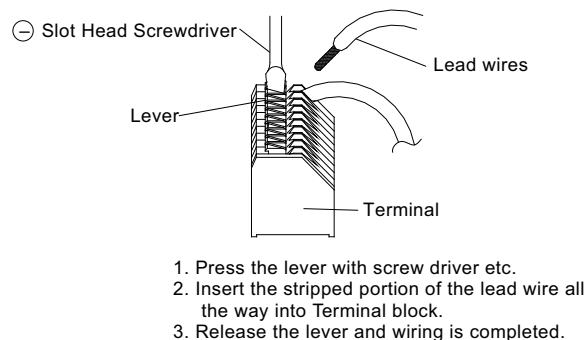

#### Caution

- When removing the lead wire, be sure to operate the lever first, before pulling the wire out.

### 5-1-2. Wiring Procedure for 90~250V Model

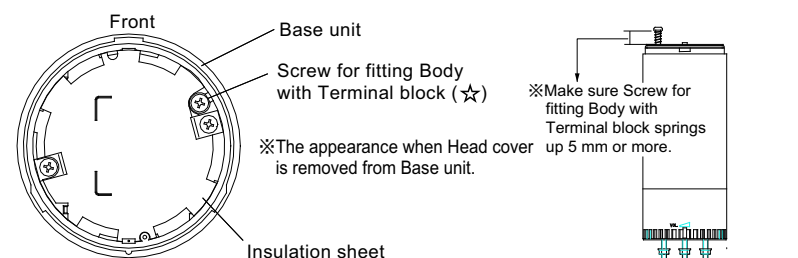

### 5-2. Wiring Example

#### LT7B Continuous Light Model

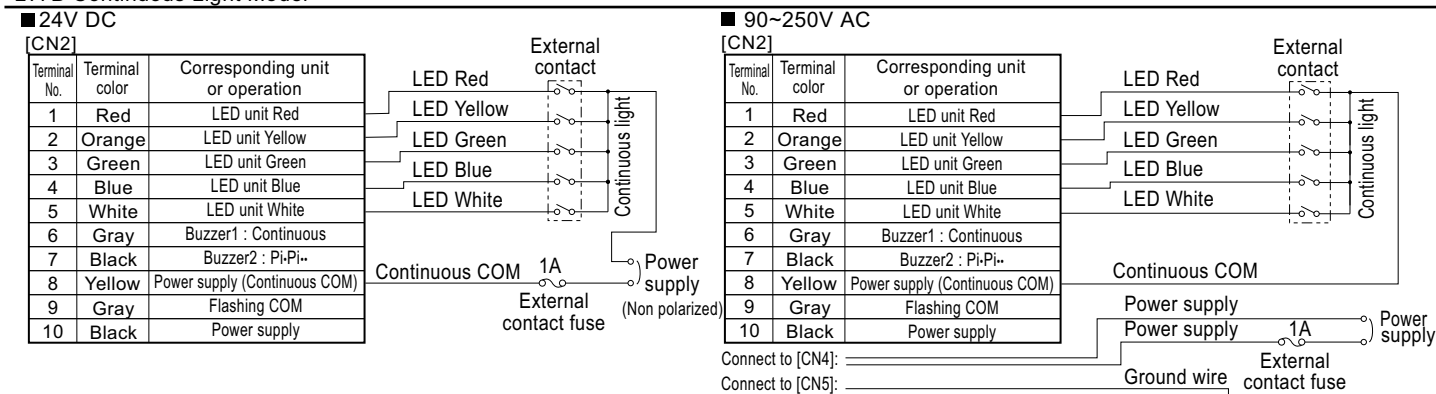

#### LT7B-FB Continuous Light or Flashing, with Buzzer

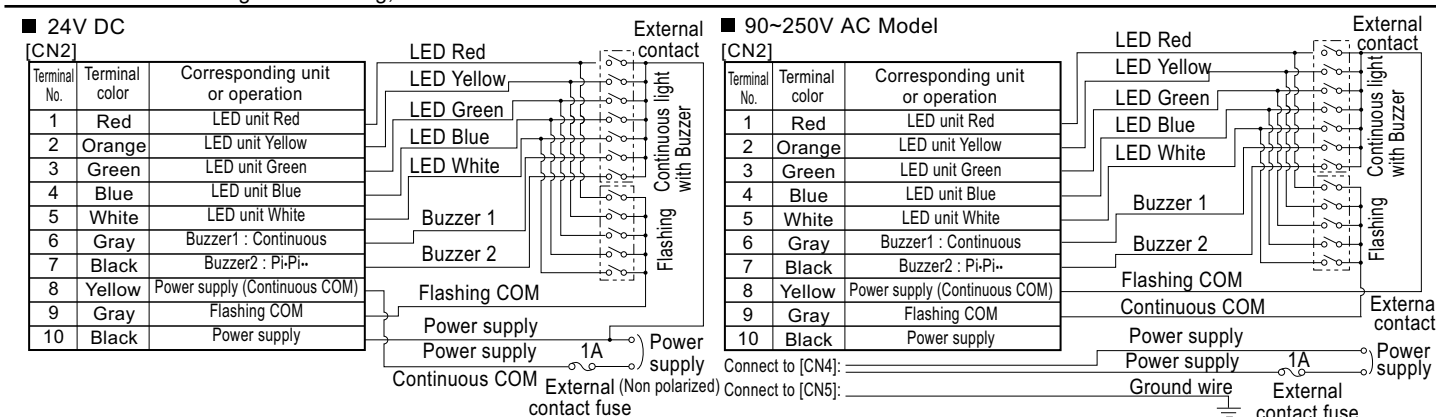

#### External Contact Capacity

Voltage Specifications		24V DC	90~250V AC
LED unit [1-Light]	Current consumption	Red•Amber : 52mA	Green•Blue•White : 42mA
	Contact capacity	Is≥100mA, Vs≥35V AC	
Buzzer	Current consumption	50mA	
	Inrush current	100mA	
	Contact capacity	Is≥100mA, Vs≥35V AC	
Power supply	Current consumption	360mA	50mA
	Contact capacity	Is≥500mA Vs≥35V AC	Is≥100mA Vs≥250V AC

#### External Contact Fuse

Voltage	Ampere rating of fuse
All model	250V 1A

- ※Use the fuse conforming to the rated current of the machine which you install product. (Example : UL Class J type fuse)
- ※Since a maximum of 10A inrush current flows through the power supply wires, select contacts with enough capacity to handle the inrush current.

\*Is: Current capacity  
Vs: Withstand voltage

#### Caution

- Make sure the power is OFF before wiring. A short circuit may damage internal circuits or cause an electric shock.
- Do not apply voltage directly to signal wires and common wires. It may damage the circuit. (90~250V AC)
- Do not pull out the lead wire or push it into the pole or the body.
- Install external contact fuse on the power supply side as shown in the wiring example in order to prevent burn in case of a wiring error.
- Failure to follow wiring instructions may cause damage to product or product may not operate properly.
- Do not apply voltage directly to Flashing common wire. It may cause a breakdown. (FB model)
- Do not connect Continuous common wire and Flashing common wire. It may damage the internal circuit.
- If using both flashing and continuous circuits, do not apply power at the same time as this may cause second color indicator to light. This also applies to both buzzer circuits.
- If you use the product with both buzzers, please use external contacts for lighting and for buzzers.

### 5-3. NPN (PNP) Transistor Drive Example

#### LT7B Continuous Light

##### NPN Transistor (24V Model)

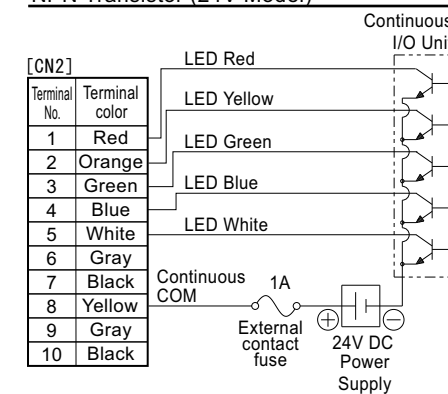

##### NPN Transistor (90~250V Model)

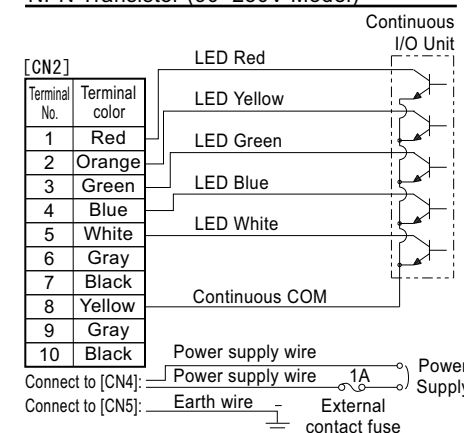

##### PNP Transistor (24V Model)

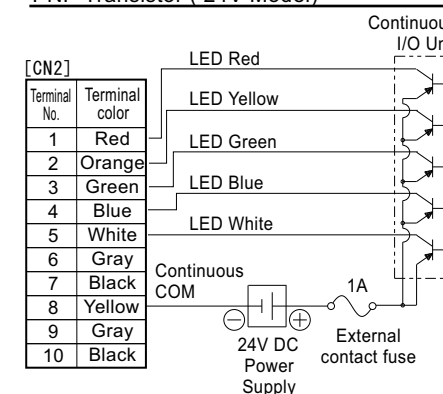

#### LT7B-FB Continuous Light or Flashing, with Buzzer Model

##### NPN Transistor (24V Model)

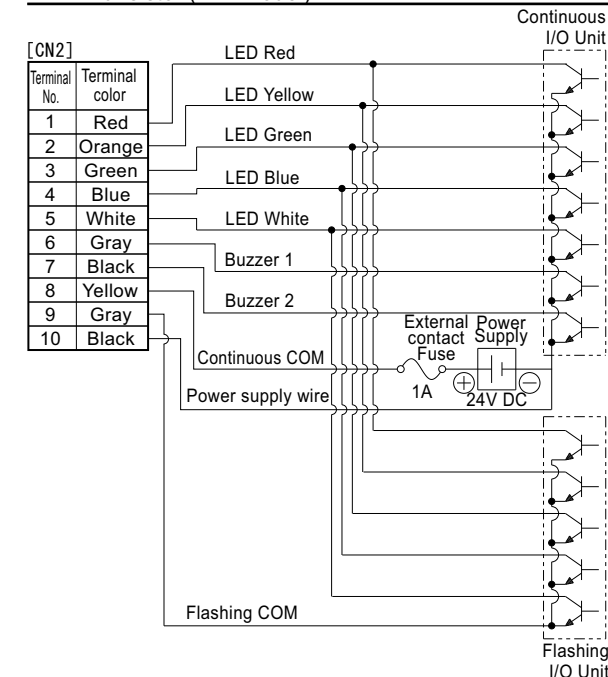

##### NPN Transistor (90~250V Model)

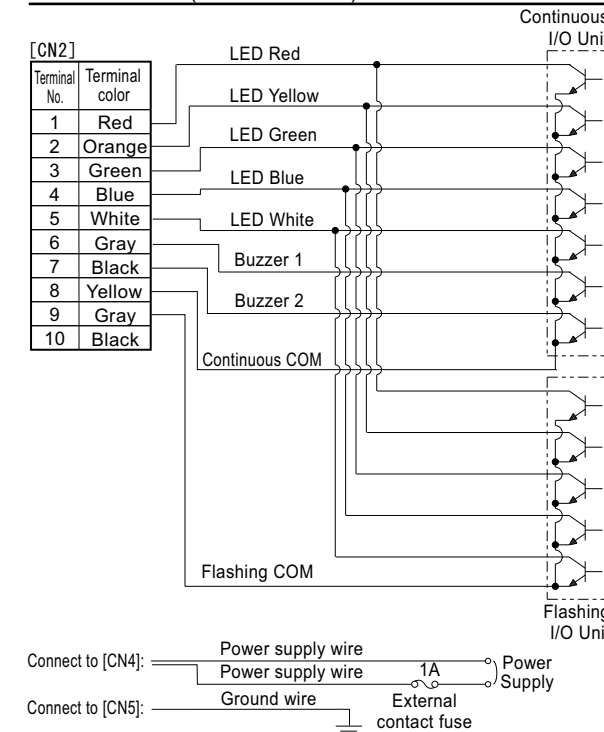

##### PNP Transistor (24V Model)

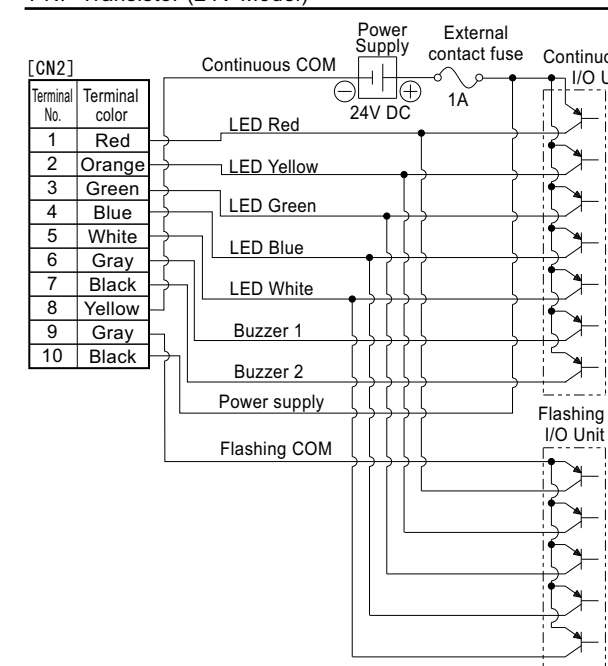

#### Recommendation transistor

Current capacity	Ic≥100mA (LED unit) (Buzzer)
Dielectric break down strength	Vc≥35V
Leakage current	IL≥0.1mA