

## 8.6 Luminous rows

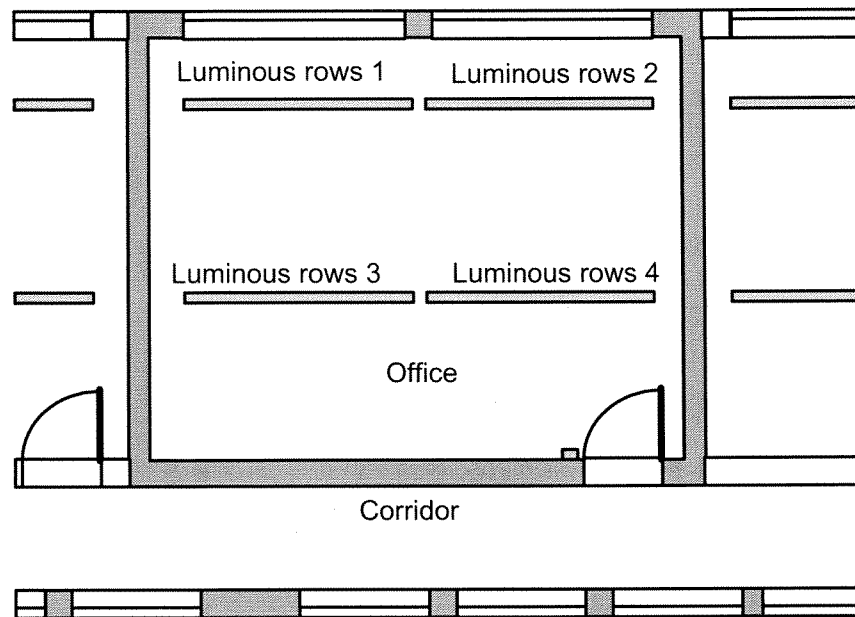

When planning lighting systems for commercial locations, the type and number of lamps used is determined by the luminance required. For reasons of cost efficiency, the installation often consists of fluorescent tubes arranged in luminous rows, and are divided into separate switching circuits, according to the way the room is used.

### 8.6.1 Requirements for a lighting system

- The various luminous rows are switched on and off locally.
- If there is sufficient daylight, the rows on the window side of the room are automatically switched off by means of a daylight control switch.
- The lights are switched off automatically at 20.00 h.
- Local manual operation of the lighting must be possible at all times.

## 8.6.2 Previous solution

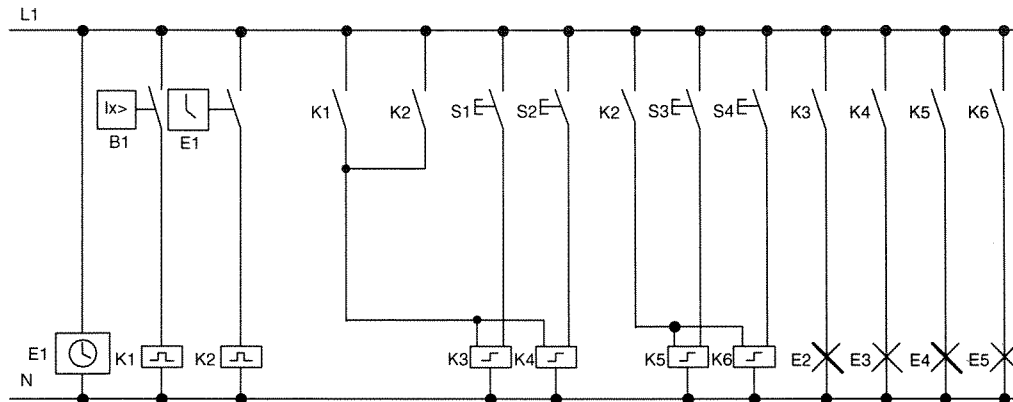

The lamps are switched on and off with pulse relays, by means of pushbutton control at the door. Regardless of this, they are reset with a timer or daylight control switch signal at the *central off* input. The pulse width of the off commands must be reduced by means of interval time-delay relays to allow operation of the lights after they are switched off.

Components required:

- Pushbuttons S1 to S4
- Daylight control switch B1
- Timer E1
- Interval time-delay relays K1 and K2
- Pulse switches K3 to K6 with central OFF function

### Disadvantages of the previous solution

- A substantial amount of switchgear needs to be installed to implement the necessary functions.
- Due to the large number of mechanical components, high wear and tear and maintenance expenditure is to be expected.
- The modification of functions involves considerable effort.

### 8.6.3 Luminous row control system with FL1D-H12RCC

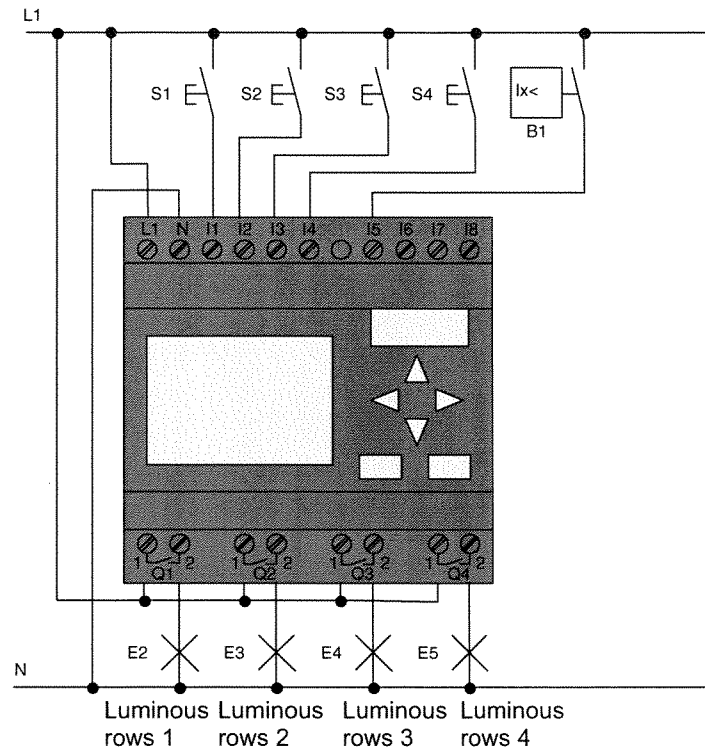

#### Components used

- S1 to S4 (normally open contact) momentary pushbutton
- B1 (normally open contact) daylight control switch

## Block diagram of the IDEC SmartRelay solution

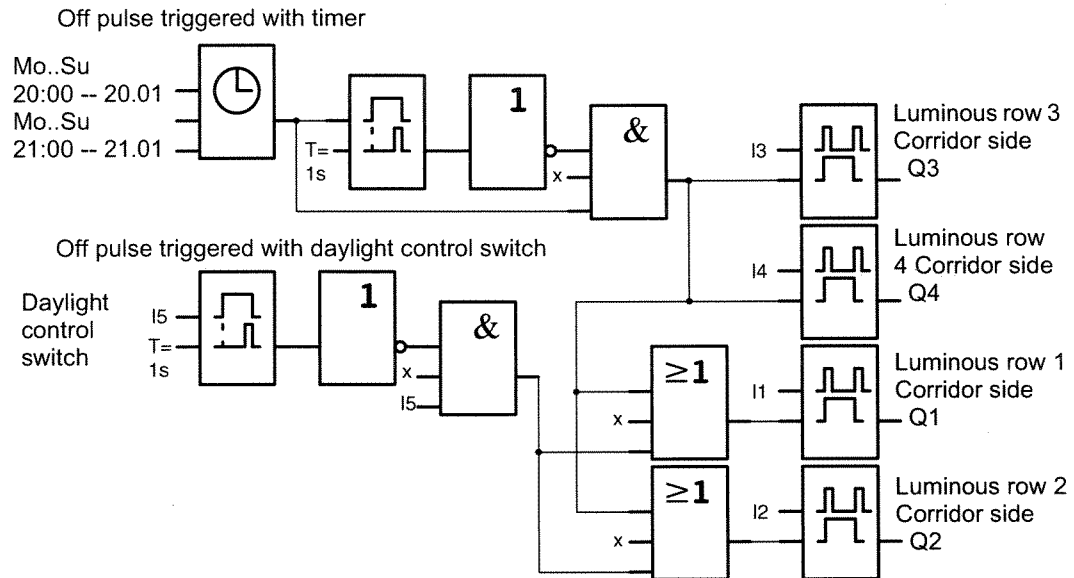

## Advantages of the IDEC SmartRelay solution

- You can connect the lamps directly to the IDEC SmartRelay, provided the power consumption does not exceed the switching capacity of the various outputs. Higher loads should be switched with a contactor relay.
- Connect the daylight control switch directly to an input of the IDEC SmartRelay.
- You do not need an external timer, because this function is integrated in the IDEC SmartRelay.
- Due to the reduced amount of switchgear, you can install a smaller and space-saving distribution cabinet.
- Fewer devices are required
- The lighting system can be easily modified.
- Additional switching times can be set as required (sequential circuit for the off pulses at the end of the day).
- The function of the daylight control switch can be easily applied to all lamps or to a modified group of lamps.