

8.3 Air-conditioning system

8.3.1 Requirements for an air-conditioning system

The air-conditioning system supplies fresh air to a room or exhausts the contaminated air from a room. Let us examine following example:

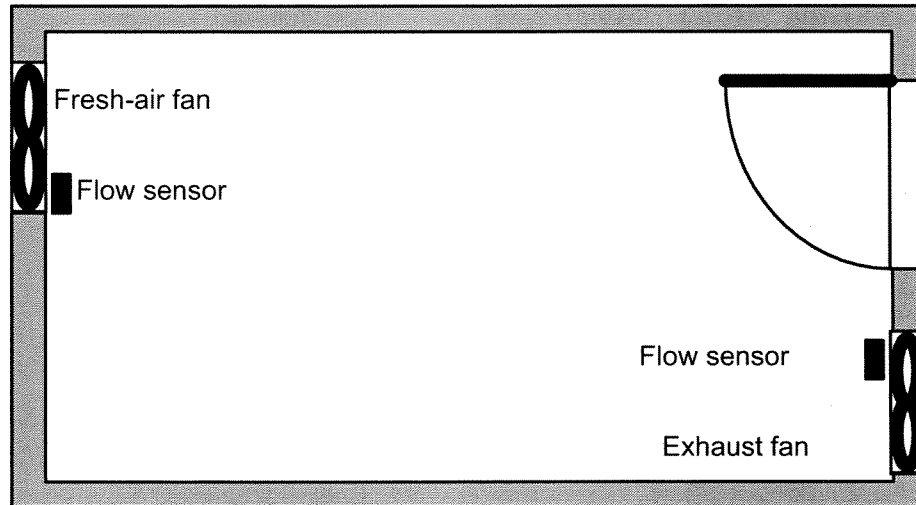

- The room is equipped with an exhaust fan and a fresh-air fan.
- Both fans are monitored by means of a flow sensor.
- An excess atmospheric pressure may never develop in the room.
- The fresh-air fan must only be switched on if safe functioning of the exhaust fan is signaled by the flow sensor.
- A warning lamp indicates failure of a fan.

The circuit diagram for conventional solutions is as follows:

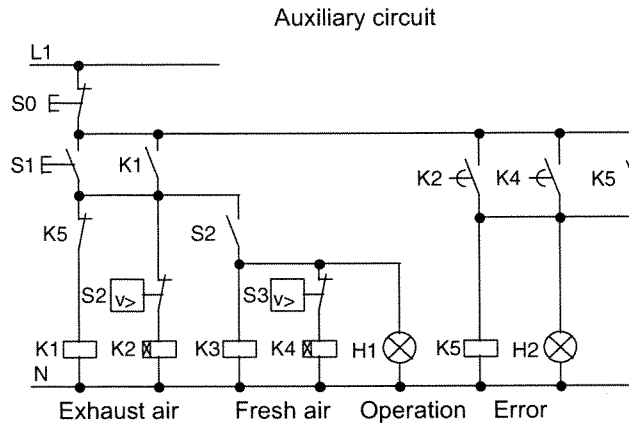

The fans are monitored by means of flow sensors. If no air flow is registered within a short waiting time, the system is switched off and an error message is output. This message can be acknowledged by pressing the OFF button.

In addition to the flow sensors, the fan monitoring system also requires an evaluating circuit with several switching devices. This evaluating circuit can be replaced by a single IDEC SmartRelay unit.

Wiring of an air-conditioning system with FL1D-H12RCC

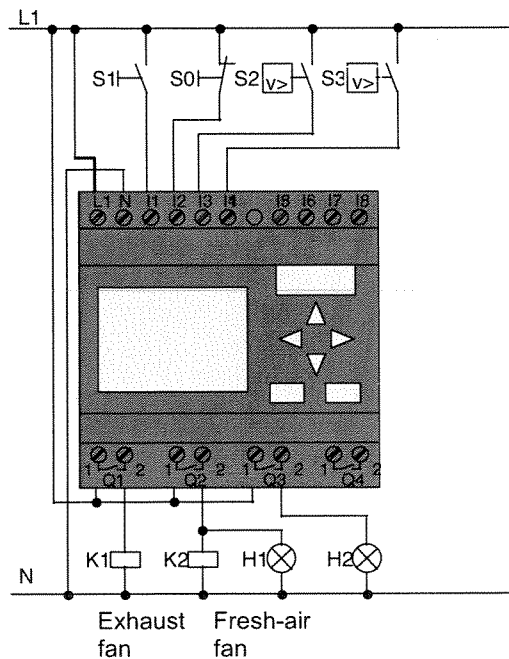

Components used

- K1 contactor relay
- K2 contactor relay
- S0 (normally closed contact) STOP pushbutton
- S1 (normally open contact) START pushbutton
- S2 (normally open contact) flow sensor
- S3 (normally open contact) flow sensor
- H1 signal lamp
- H2 signal lamp

Block diagram of the IDEC SmartRelay solution

The block diagram of the air-conditioning system with IDEC SmartRelay :

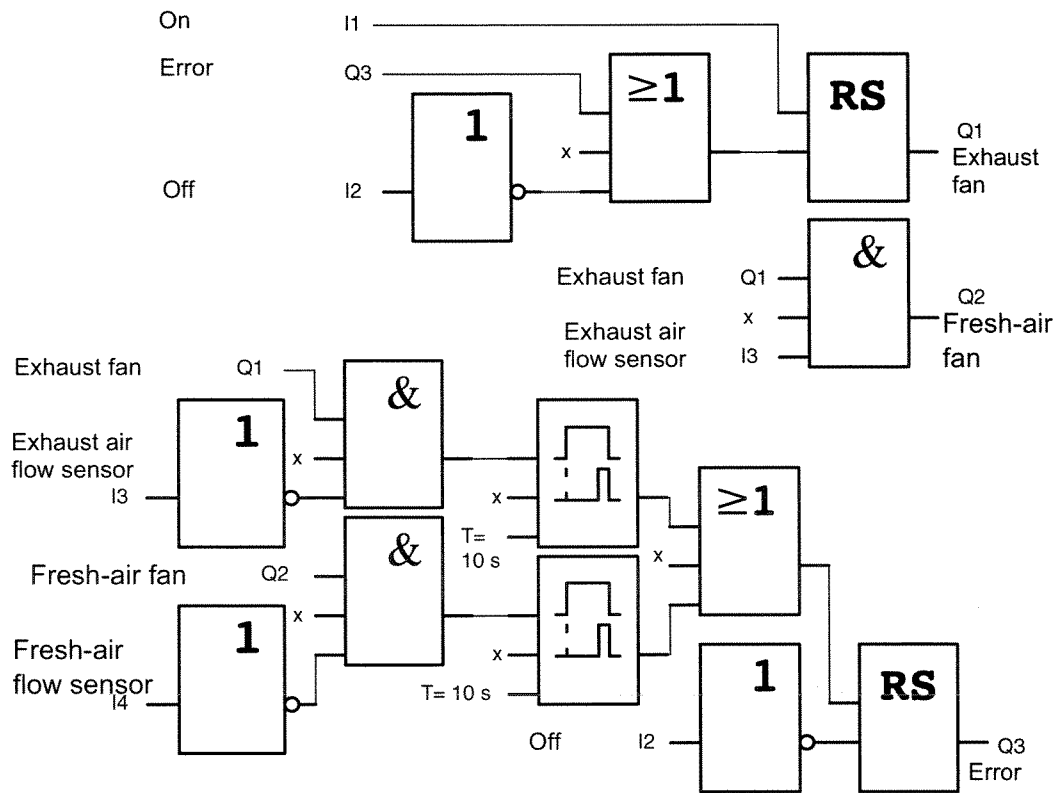

8.3.2 Advantages of using IDEC SmartRelay

The IDEC SmartRelay solution requires less switchgear. That saves you installation time and space in the control cabinet. You might even be able to use a smaller switching cabinet.

Additional IDEC SmartRelay options

- The free output (Q4) can be used as isolated signal contact for reporting faults or power failure.
- It is possible to switch off of the fans by means of a sequential circuit.

These functions can be implemented without additional switchgear.

Block diagram of the extended IDEC SmartRelay solution

The fans at Q1 and Q2 are switched on and off by means of the following circuit:

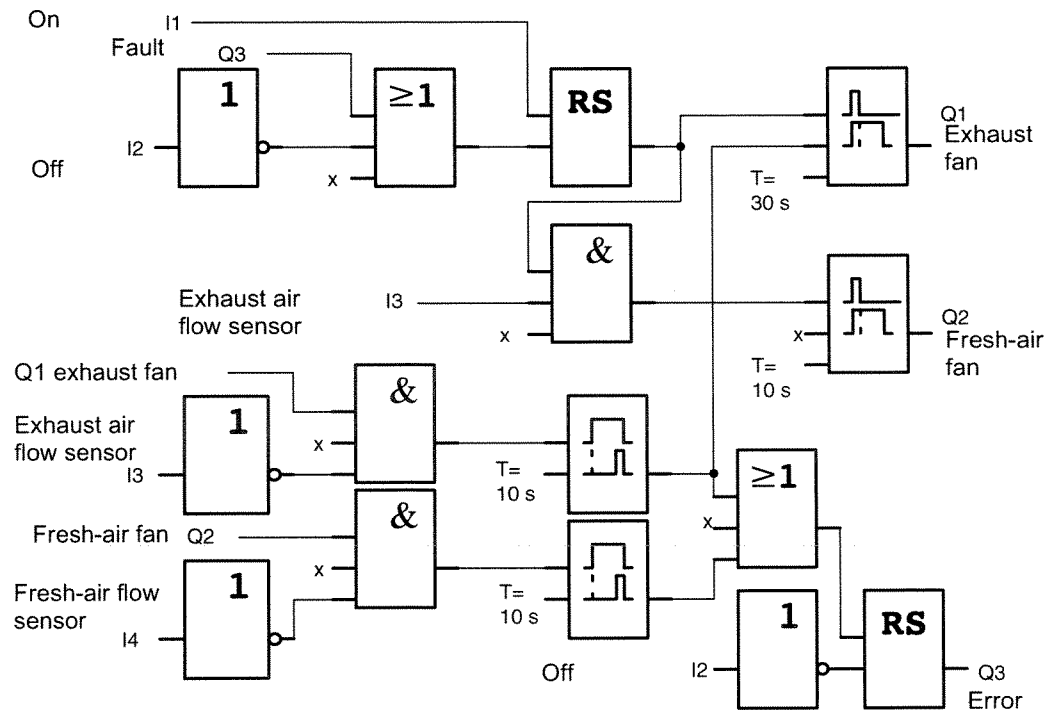

You can also generate a message at output Q4:

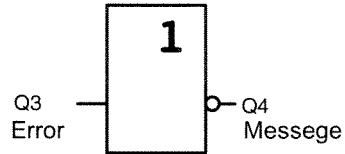

The relay contacts of output Q4 are always closed when the system is in operation. Relay Q4 does not drop off unless there is a power failure or a fault in the system. This contact can be used for remote monitoring, for example.