



**Communication Settings for
Automation Direct (Koyo)
DL240 CPU and D2-240 CPU**

and

**IDEC Touchscreens
(5.7" HG2F, 10.4" HG3F, 12.1" HG4F)**

Introduction

This information will help you configure IDEC touchscreens (5.7” HG2F, 10.4” HG3F, or 12.1” HG4F) and the Automation Direct (Koyo) PLC (CPU: D2-240) using DirectLogic-DL205/405 protocol. For other supported Automation Direct PLCs and communication settings/ range of addresses, please refer to WindO/I-NV2 Manual. Select “Host Interface,” then Connection to a PLC.

<http://www.idec.com/Products/ENG/PDF/manuals/WindOI/V282/English/mainmenu.pdf>

DirectLogic 205 (connects to CPU unit RS-232C port)



Cable Part number: Not available (wiring diagram only)

D2-240(CPU unit RS-232C port) to HG2F/2S/3F/4F

HG2F/3F/4F

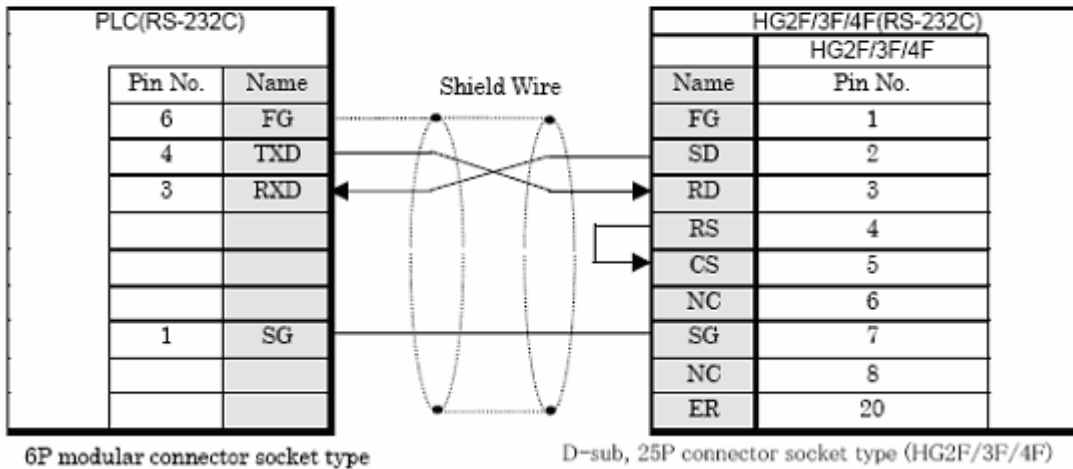

Communication Settings

Items	Details
Serial Interface	RS-232C
Data representation	HEX mode
Slave Address	1 – 90(DEC)
Baud Rate (bps)	9600
Data Bits (bit)	8 (fixed)
Parity	None, Odd
Stop Bits (bit)	1 (fixed)
Flow Control	ER control

Addressing

15.5.2 DL205

HG Device Name	HG Device Symbol	PLC Device Name	PLC Device Symbol	Address range	Read /Write	Address Gradual
Input Points (Bit)	X	Input Points	X	0 - 1777	R	8(octal)
Output Points (Bit)	Y	Output Points	Y	0 - 1777	R/W	8(octal)
Control Relays (Bit)	C	Control Relays	C	0 - 3777	R/W	8(octal)
Stages (Bit)	S	Stages	S	0 - 1777	R/W	8(octal)
Timer Status (Bit)	TS	Timer Status Bits	T	0 - 377	R	8(octal)
Counter Status (Bit)	CS	Counter Status Bits	CT	0 - 377	R	8(octal)
Remote In (Bit)	GX	Remote Input Points	GX	0 - 3777	R/W	8(octal)
Remote Out (Bit)	GY	Remote Output Points	GY	0 - 3777	R/W	8(octal)
Special Relays (Bit)	SP	Special Relays	SP	0 - 777	R	8(octal)
Input Points (Word)	XW	Input Points	V	40400 - 40477	R	8(octal)
Output Points (Word)	YW	Output Points	V	40500 - 40577	R/W	8(octal)
Control Relays (Word)	CW	Control Relays	V	40600 - 40777	R/W	8(octal)
Stages (Word)	SW	Stages	V	41000 - 41077	R/W	8(octal)
Remote In (Word)	GXW	Remote Input Points	V	40000 - 40177	R/W	8(octal)
Remote Out (Word)	GYW	Remote Output Points	V	40200 - 40377	R/W	8(octal)
Special Relays (Word)	SPW	Special Relays	V	41200 - 41237	R	8(octal)
Timer Values	TV	Timer Current Values	V	0 - 377	R/W	8(octal)
Counter Values	CV	Counter Current Values	V	1000 - 1377	R/W	8(octal)
Data Registers	D	Data Words	V	1400 - 7377	R/W	8(octal)
System Parameters1	SR1	Data Words	V	400 - 777	R	8(octal)
System Parameters2	SR2	System Parameters	V	7400 - 7777	R	8(octal)
Ext Registers	ER	Data Words System Parameters	V	10000 – 35777 36000 – 37777	R/W	8(octal)



We confirm only D2-240 address range. Depending on the type of PLC that you will be using, there are limits to the areas that can be used within the device ranges given above. Refer to the PLC manual for details.



When selecting Bit Write, operation depends on the project settings which has an option to turn off all other bits in the byte or leave all other bits without change. Check or uncheck the check box for "Bit Write operation will write to a byte." (Byte refers to 8 bits.)

Check: When executing Bit Write, all other bits in the byte are turned off. Uncheck: When executing Bit Write, all other bits are not changed. During Bit Write operation, the HG reads the byte data including the designated bit from the PLC, performs logical AND or OR operation with the designated bit, and writes the result into the PLC, therefore all other bits in the byte are not changed.

Items used for this example:

- DL205: DL240 CPU, HG2F-SS22VF
- Cable part no. HG9Z-XCM1A (programming cable between PC and HG2F/3F/4F)
- Cable between Koyo DL205 and HG2F/3F/4F)
- Cable part no. D2-DSCBL (programming cable between PC and Koyo DL205)
- HG9Y-ZSS2W (WindO/I-NV2 programming software for HG2F/3F/4F)
- DirectSoft (Windows-based programming software for Koyo DL205 Series, DL240 CPU)

Step1: DirectSoft (Software for Koyo DL205 Series)

- 1) Connect cable part number D2-DSCBL to PC and Koyo PLC (port 1).
- 2) Launch DirectSoft programming software.
- 3) Select the New Link to set the COM PORT

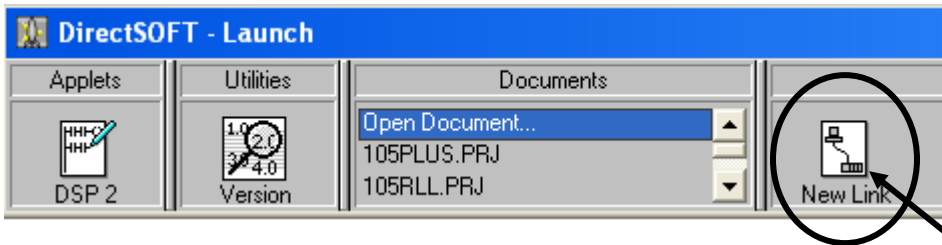

- 4) In the “Ports”, select the COM Port your computer is using. Click Next to continue. In this example, COM 4 is used.

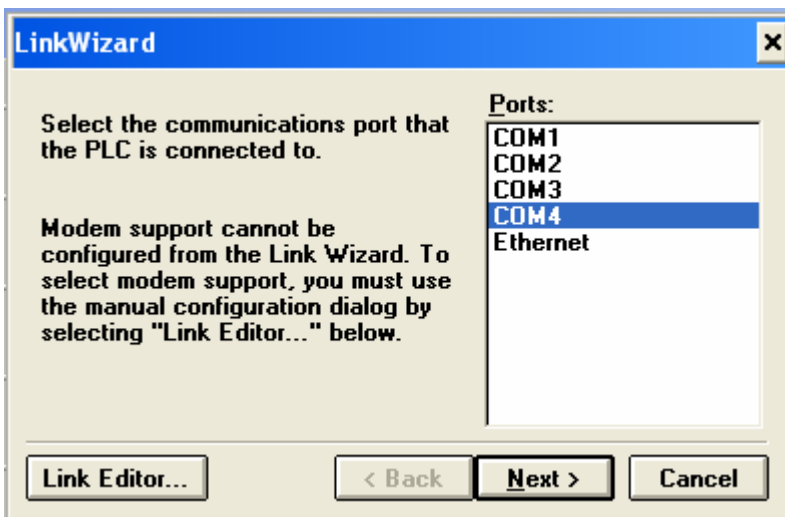

- 5) Select the PLC type. “Not Sure” is selected. Click Next to continue.

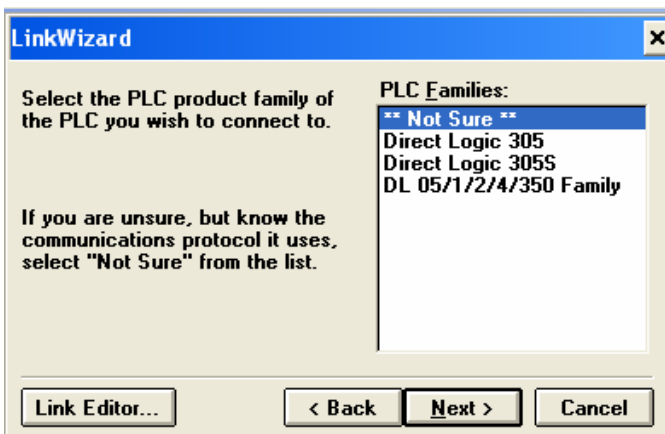

- 6) The protocol is K Sequence and the node Address is 1. Click Next to continue.

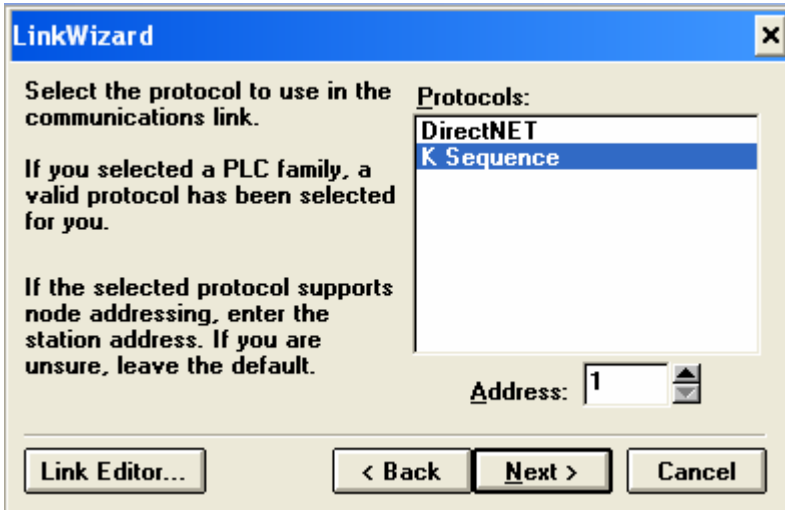

- 7) If connection is successful, the image below is displayed in your screen. Enter the Link Name. In this example, DL205 is the Link Name. Click the Finish button to close.

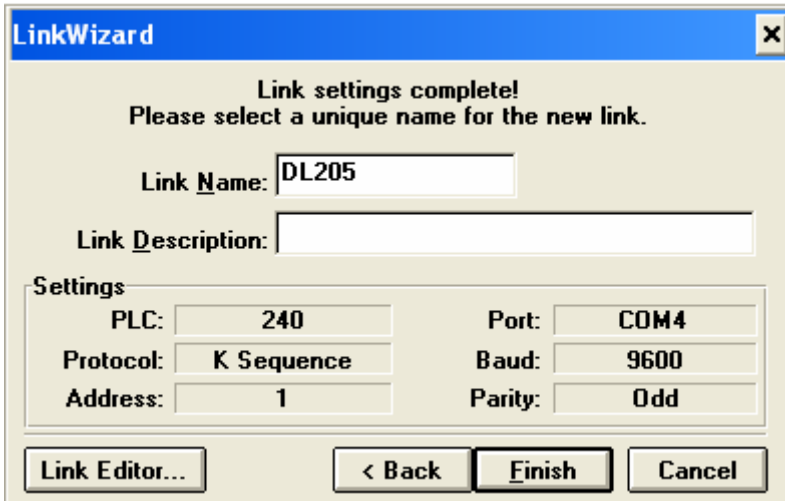

- 8) The Link icon between the PLC and PC is displayed.

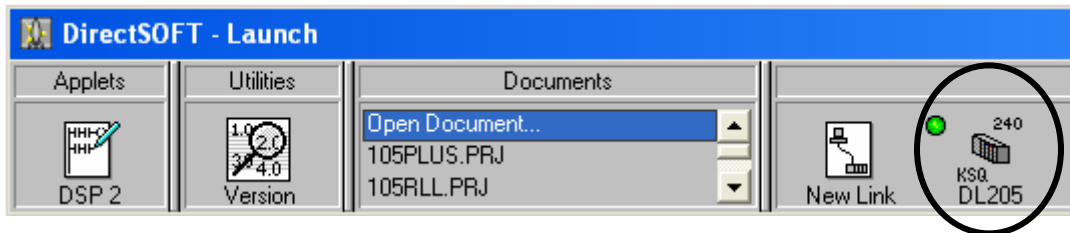

9) Select “Applets” to create a Ladder Logic.

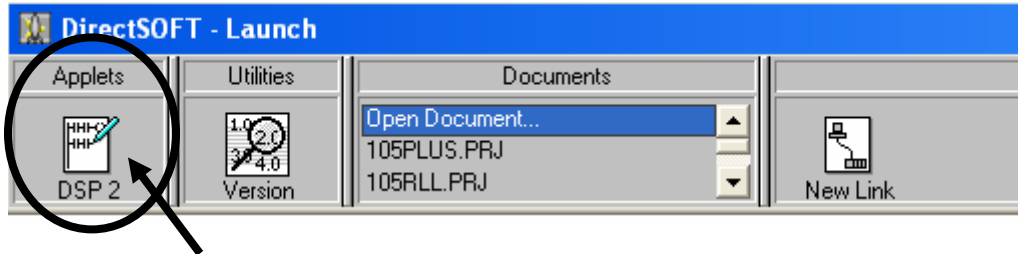

10) Enter the New Project name. In this example, the project name is “SAMPLE”
Family: Direct Logic 05/1/2/4/350
Type: DL 240
Click the OK button to close.

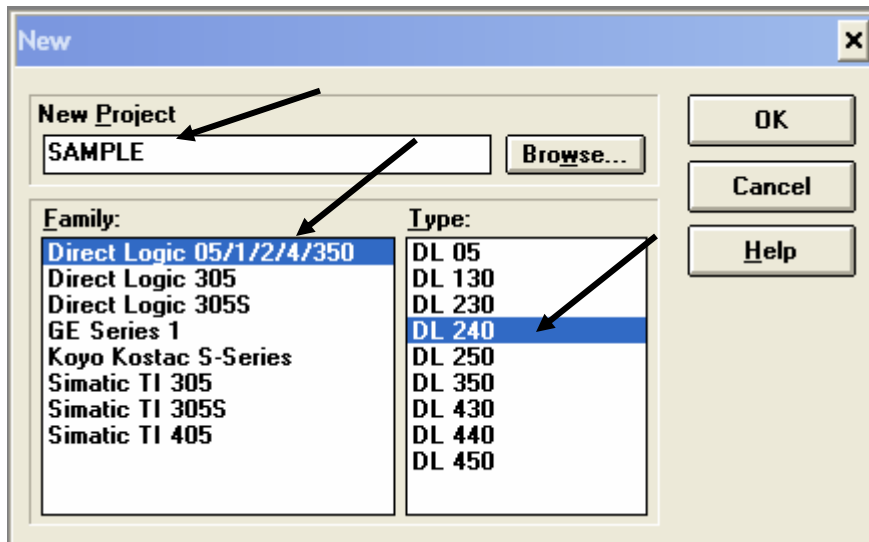

11) In the Ladder, select Edit-Edit Mode and a tool box with components will appear.

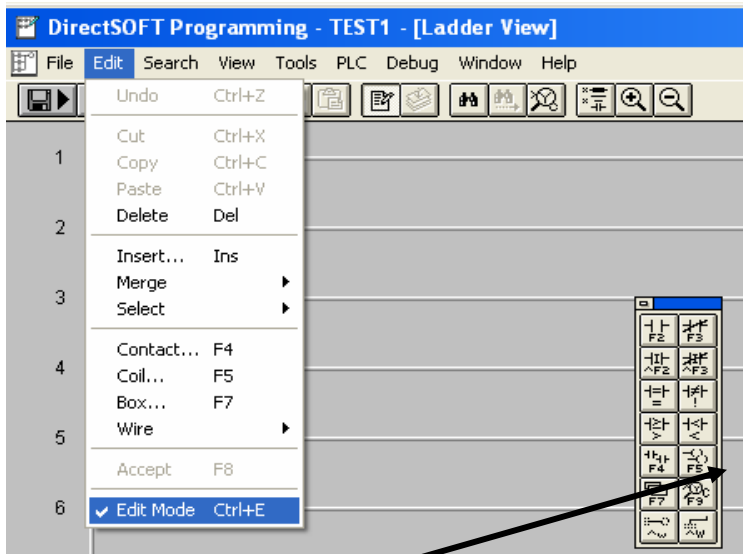

12) Click the first column of the rung and select Normally Open contact (F2) from the tool box.

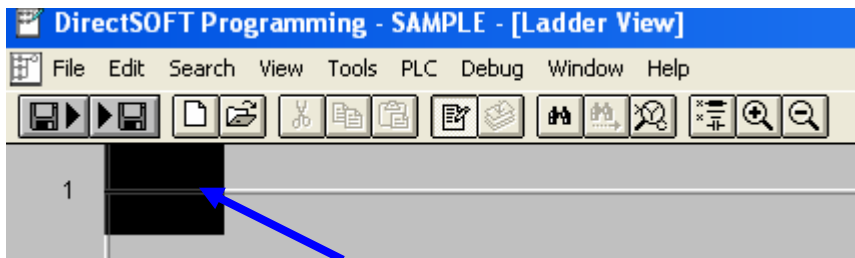

- 13) Double click the white box (arrow pointing) to view the Element Browser. Select X0 under Valid Ranges to get the element X0. Then click the Select button.

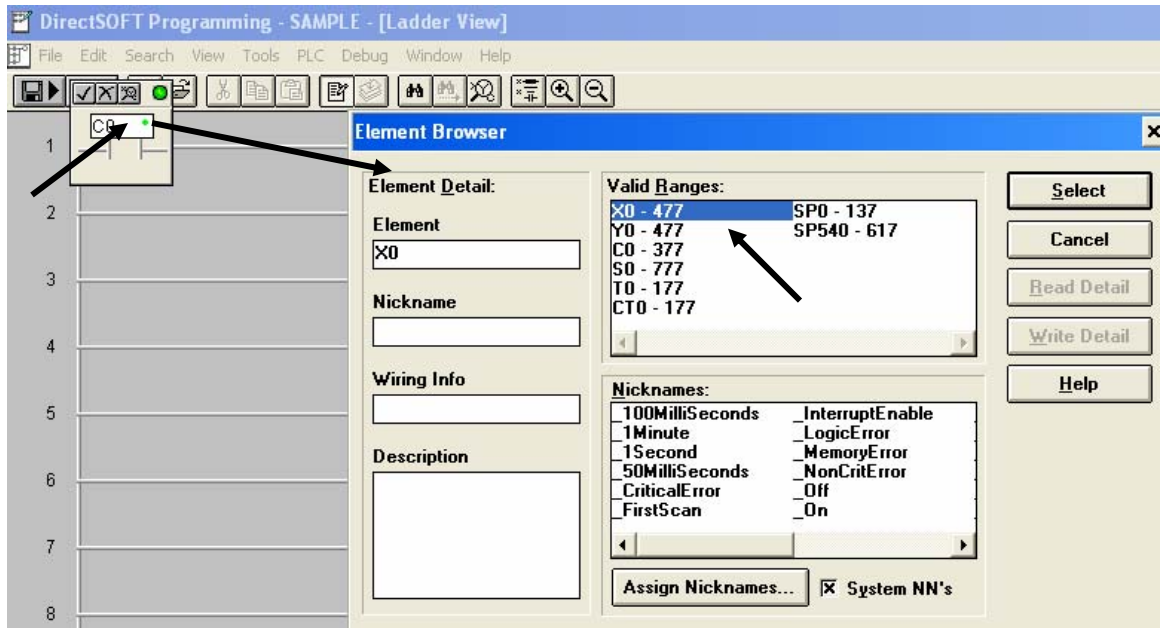

- 14) Now, by pressing the Enter key from your keyboard, the normally open contact is displayed (as shown).

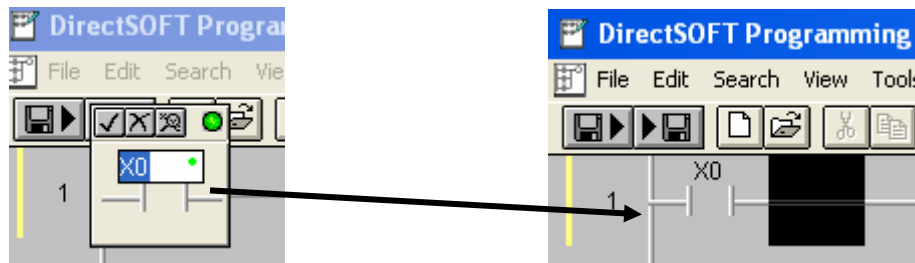

- 15) Move the mouse at the end of the rung and double click on the block. Repeat Step #12(above) and select Y0 as the address. Select the Output Icon (F5) and drop it on the right side of Rung 1.

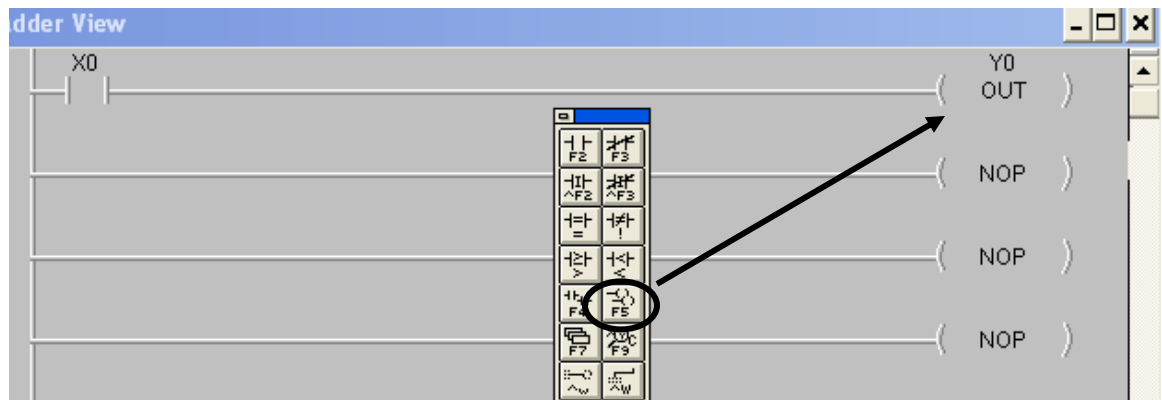

16) Add an END statement on Rung 2. Select the Output Coil (F5) and drop it on the right side of Rung 2.

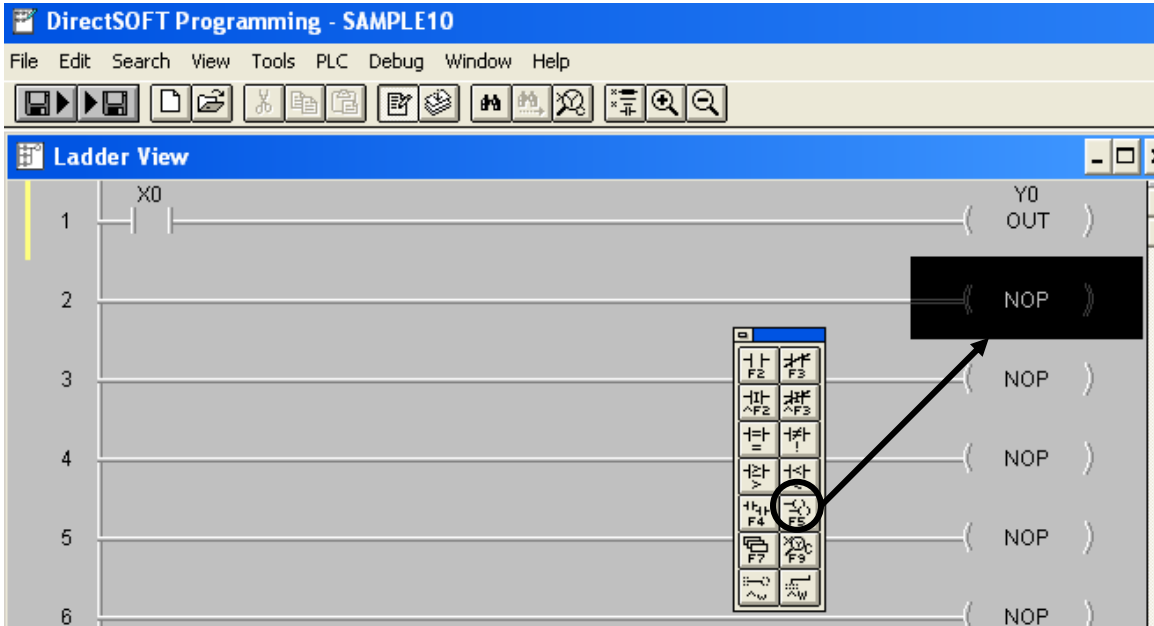

17) Select "Program Control". The Coil is "END". Click OK to select. Then press your Enter key from your keyboard to accept the End statement.

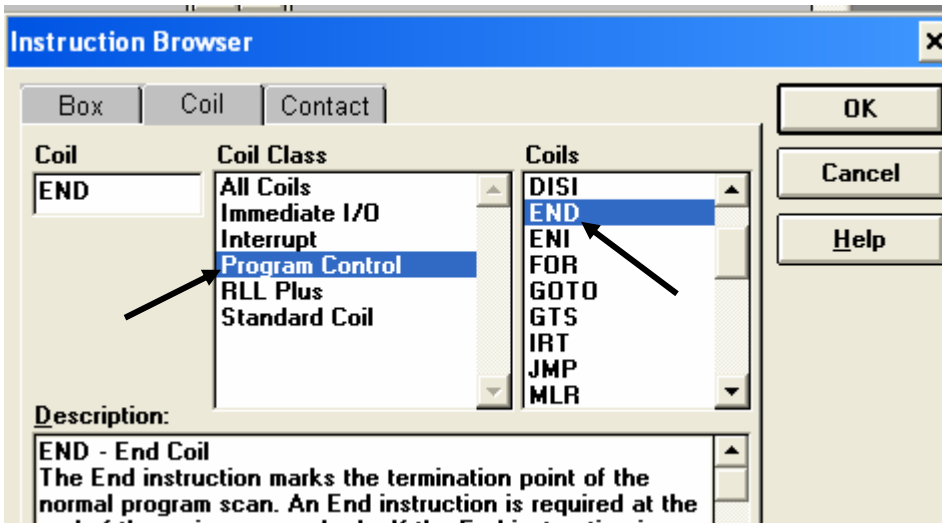

This is the complete rungs.



Step 2: Download the PLC program

- 1) Select File- Save Project- to Disk. In the Koyo CPU, switch the mode from RUN to TERM.
- 2) Select PLC-Connect

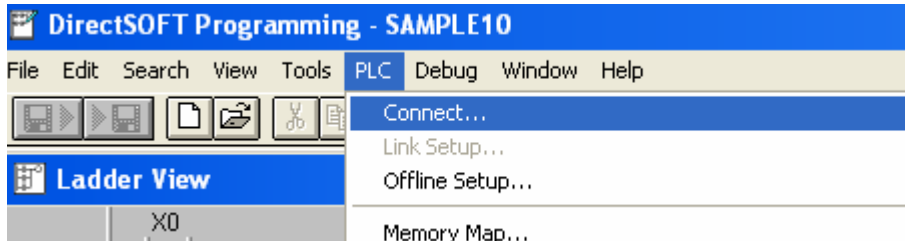

- 3) Press the "Select" button to continue.

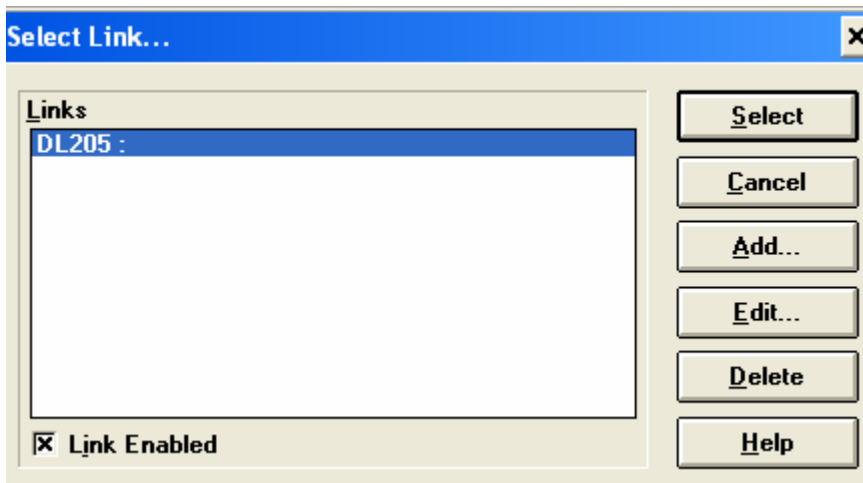

- 4) Select "Use Disk".

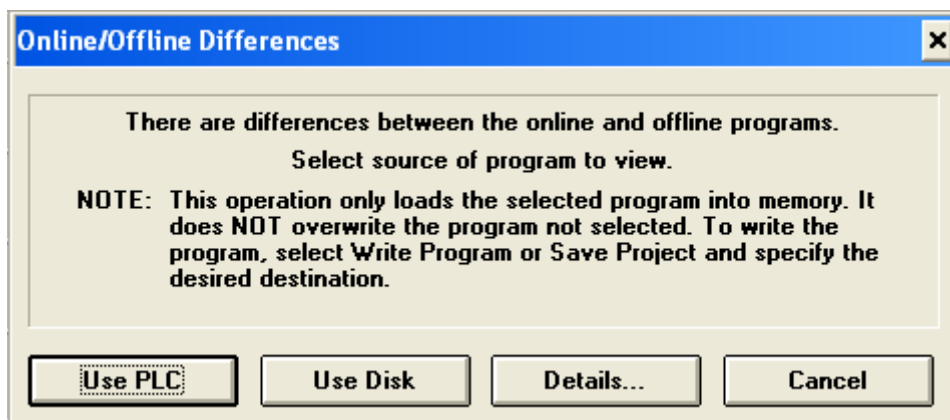

- 5) Select PLC-Setup-Setup Secondary Communications Port. Follow all settings in this image.

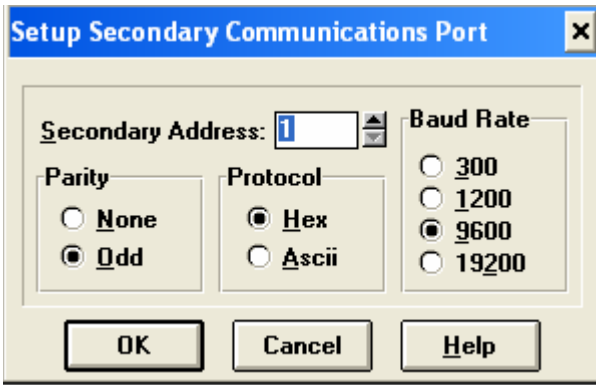

- 6) Download the project by selecting File-Write Program-to PLC.

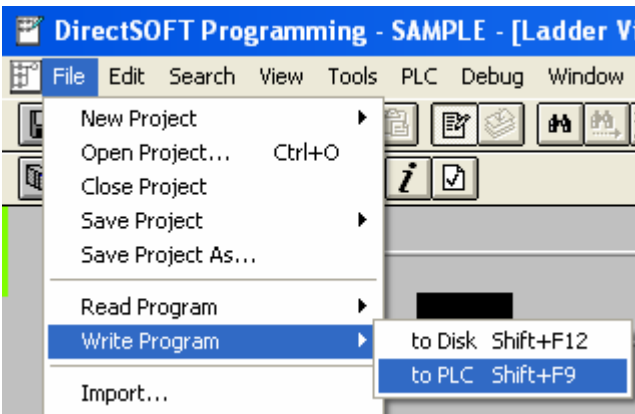

- 7) From the top menu, select PLC-PLC Modes. Make sure you select RUN mode.

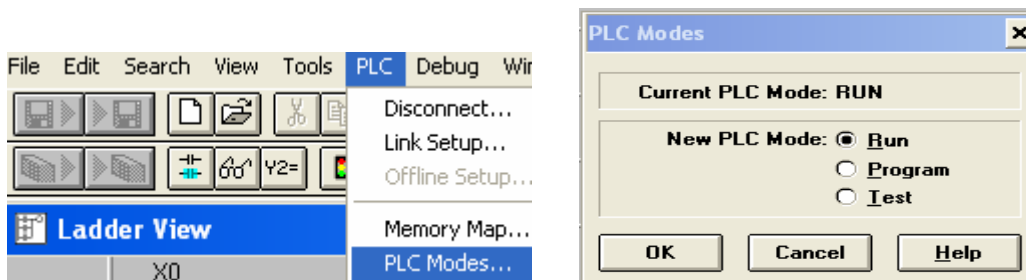

- 8) Switch the CPU from TERM TO RUN mode.

Step 3: WindO/I-NV2 Software

- 1) Connect cable part number HG9Z-XCM1A between PC and HG2F/3F/4F.
- 2) Launch WindO/I-NV2 software.
- 3) Select File-New Project

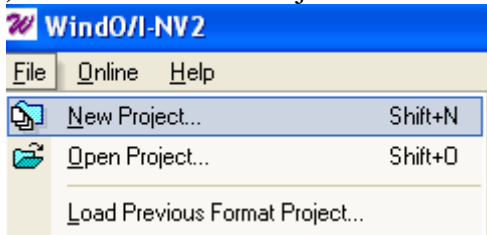

- 4) Enter a File name for the project. In this example, the project name is “test.” Click the Next button to continue.

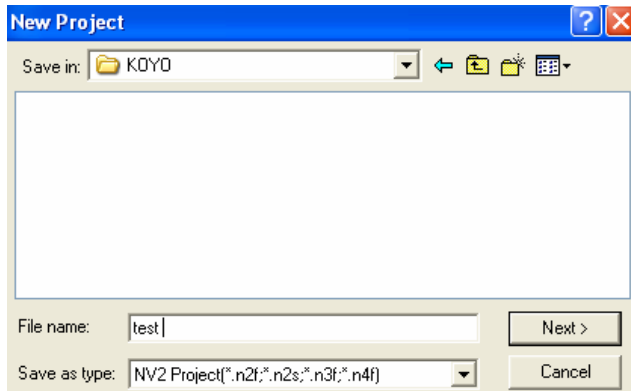

- 5) Select the O/I and Model type. Click the Next button to continue.

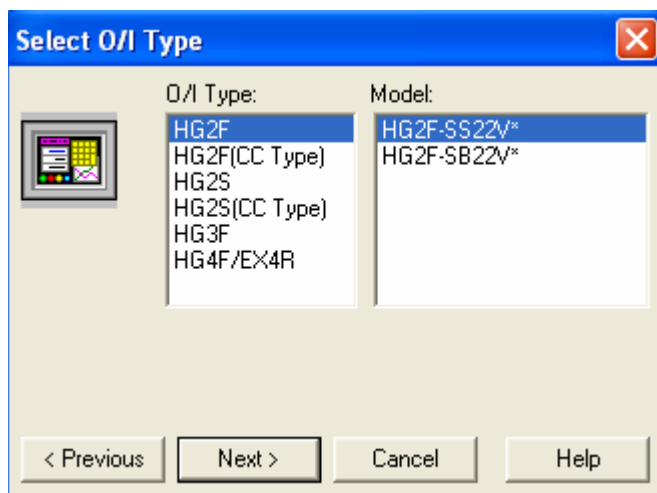

- 6) Select the following:
Manufacturer: Koyo
Protocol: DirectLogic-DL205/405
Connection Type: 1:1
Click Next to continue.

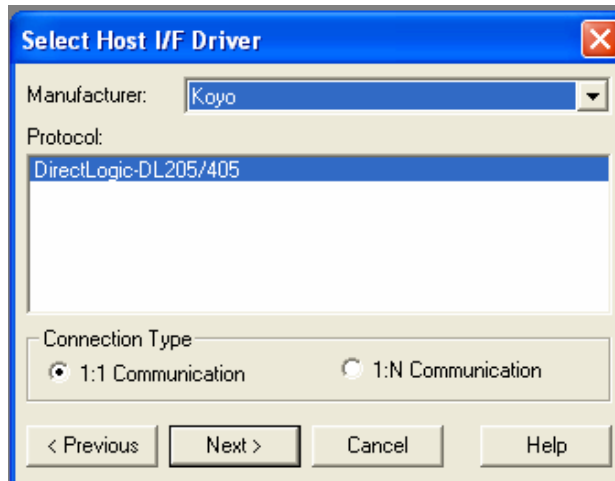

- 7) Project Settings:
- Select Communication Interface.
 - In the Interface Configuration, select SERIAL 1 Host Communication.
 - For communication settings, follow the information under Interface Settings.

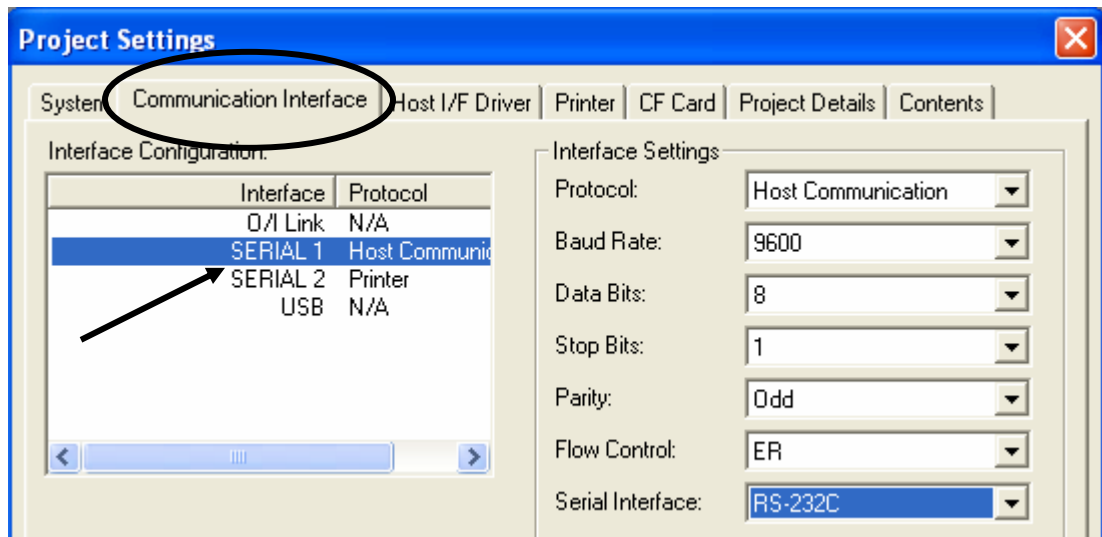

- 8) Next select the Host I/F Driver. Follow the settings below. Click OK to close the Project Settings.

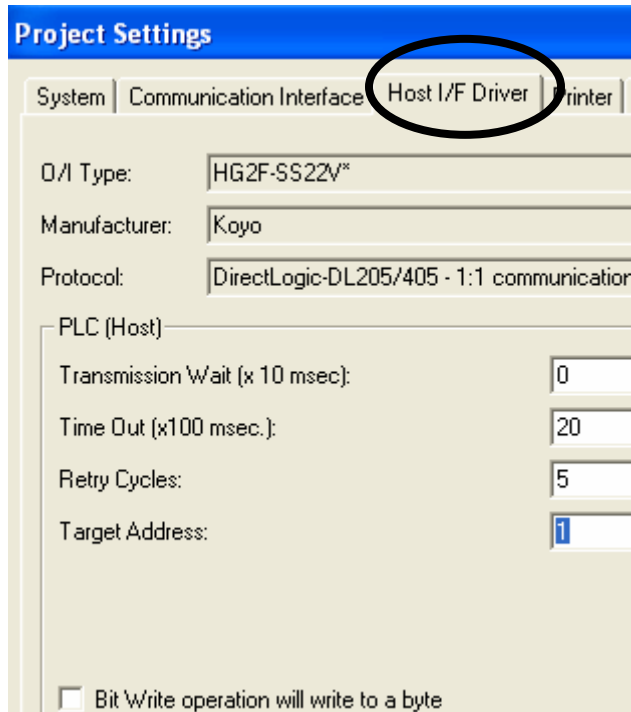

- 9) Click the OK button to close the Screen Properties. On the Base Screen do the following:
- Select the Bit Button and drop it on the Base Screen.
 - Double click on the button to open the Properties of Bit Button.

In the General tab:

- Action Mode : Alternate
- Destination Device: Y0

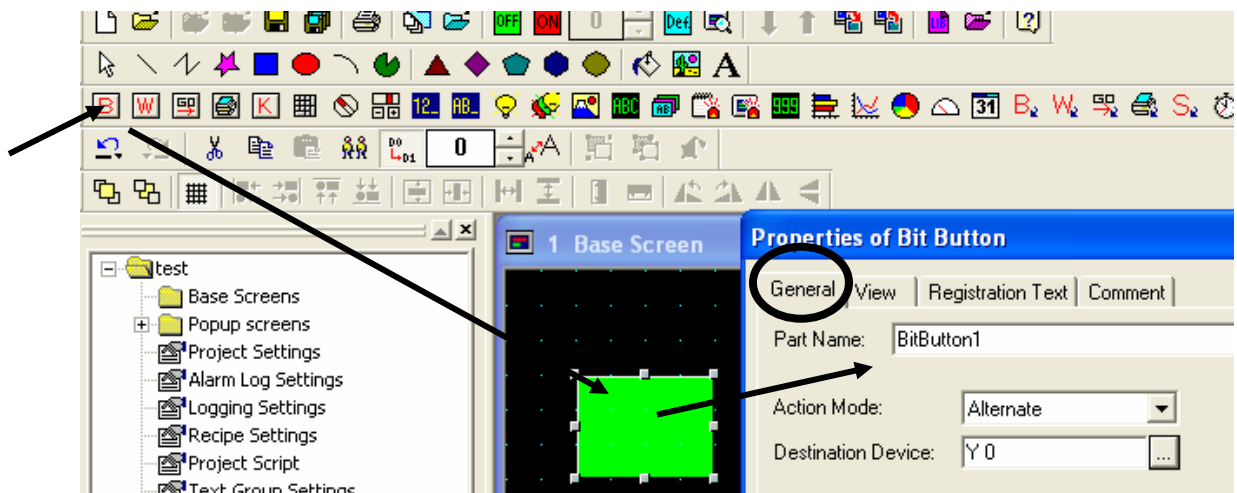

10) Select Online-Download to download the project in the Koyo PLC.

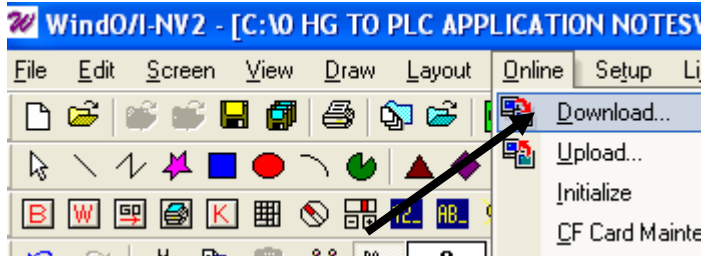

Once both programs are downloaded to the PLC and touchscreen, connect cable on Port 2. Press the button on the screen to see if it is writing to the PLC. If so, then communication is successful. You may now continue with your project.