



**IDEC (5.7" HG2G, 10.4" HG3F & 12.1" HG4F) Touchscreen
and
Micrologix Series
(Using AB Ethernet/IP Driver)**

Tutorial Guide

ALLEN BRADLEY ETHERNET/IP

HARDWARE QUESTIONS:

Q. Which Idec Touchscreen models support Ethernet/IP Driver?

A. HG2G- (5.7" STN), HG3F- (10.4" TFT Screen) and HG4F- (12.1" TFT Screen) only.

Q. Which Allen Bradley PLCs are supported by Ethernet/IP Driver?

A. Micrologix Series, SLC 505, PLC 5, and ControlLogix. See table below for complete information.

Series	PLC	Link Unit	Host I/F Driver
MicroLogix	MicroLogix1000 MicroLogix1200 MicroLogix1500	1761-NET-ENI	MicroLogix/SLC (Ethernet/IP)
SLC500	SLC5/05(1747-L551)	Ethernet Port in CPU Unit	
PLC-5	PLC-5/20E(1785-L20E) PLC-5/40E(1785-L40E) PLC-5/80E(1785-L80E)	Ethernet Port in CPU Unit	PLC-5 (Ethernet/IP)
	PLC-5	1785-ENET	
ControlLogix	ControlLogix5550 (1756-L1,-L1M1,-L1M2,-L1M3) ControlLogix5555 (1756-L55M12,-L55M13,-L55M14, -L55M16,-L55M22,-L55M23,-L55M24)	1756-ENBT	ControlLogix (Ethernet/IP)

Q. How many AB PLCs can the Idec Touchscreen connect to?

A. One Idec Touchscreen can connect up to 16 AB PLCs (all like PLCs or combination of Micrologix, SLC504, PLC 5, and ControlLogix are ok).

Introduction:

The information here demonstrates on how to configure the Idec Touchscreens (10.4" & 12.1" TFT) and Allen Bradley Micrologix PLC using the AB Ethernet/IP Driver.

Devices / Accessories needed for testing:

1. IDEC Touchscreen (5.7" HG2G, 10.4" or 12.1")
2. WindO/I-NV2, Ver. 3.01
3. Programming cable for Idec Touchscreen: HG9Z-XCM1A
4. PLC: AB Micrologix 1000 (was used in this testing)
5. 1761-NET-ENI (Interface/Converter Module used with Micrologix), Series D
6. Configuration Utility for ENI (available in Allen Bradley website for download)
7. 1761-CBL-AM00 (cable to connect Ethernet Module and Micrologix)
8. 1761-CBL-PM02 (Micrologix programming cable)
9. Ethernet cables (need 2)
10. IP Addresses (need 2)

* IDEC IP ADDRESSES are used for this example (others, please consult your IT for IP Addresses):

- a) 192.168.104.32 (assigned in the Touchscreen)
- b) 192.168.104.33 (assigned in the Micrologix/Interface Module)
- c) Subnet Mask: 255.255.255.0 (use on Touchscreen & Interface Module)
Default Gateway: 192.168.104.254 (use on Touchscreen & Interface Module)

Step.1: Configure 1761-NET-ENI (AB Interface Module)

Important*

When using AB Interface Module 1761-NET-ENI, please download the ENI/ENIW Utility software from Allen Bradley's web site (click link below). This is to configure the AB Interface Module.

(<http://www.ab.com/programmablecontrol/plc/micrologix1000/networkinterfaces.html>)

[ENI & ENIW Configuration Utility, Series D \(compatible with all series ENI & ENIW\)](#)

1. Connect programming cable (1761-CBL-PM02) from PC to Interface Module (1761-NET-ENI)
2. Set the Interface Module to "External" (located on the lower area of the module).

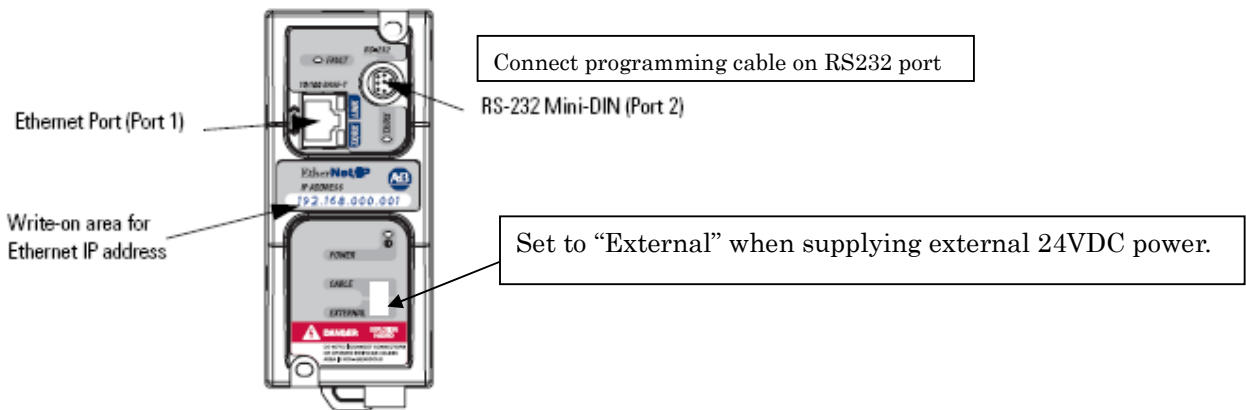

3. Supply 24VDC
4. Open the ENI / ENIW Utility software:

- a) Select "ENI IP Addr" (tab)

Follow all exact settings that are shown on this image (indicate with circles).

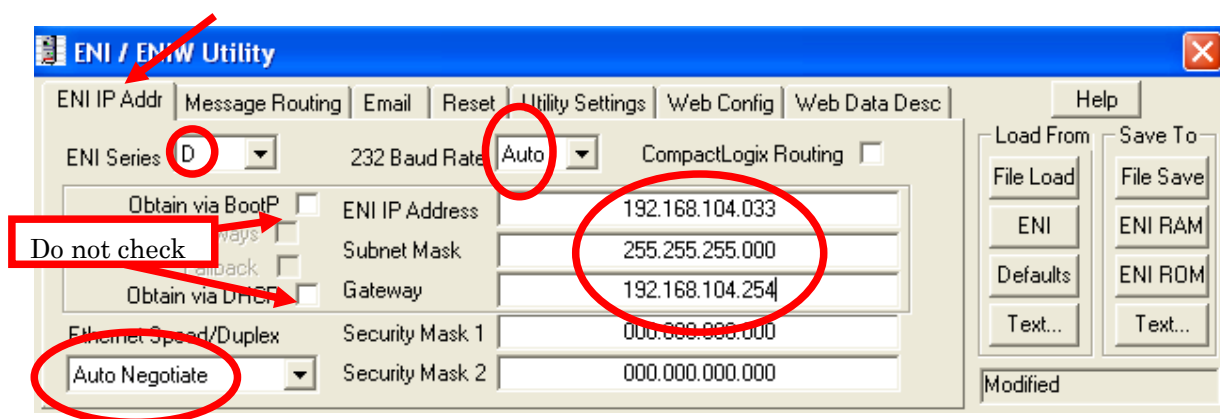

5. Select “Message Routing” (tab), enter the IP Address as shown (192.168.104.032). This IP Address is assigned in the Idec Touchscreen.

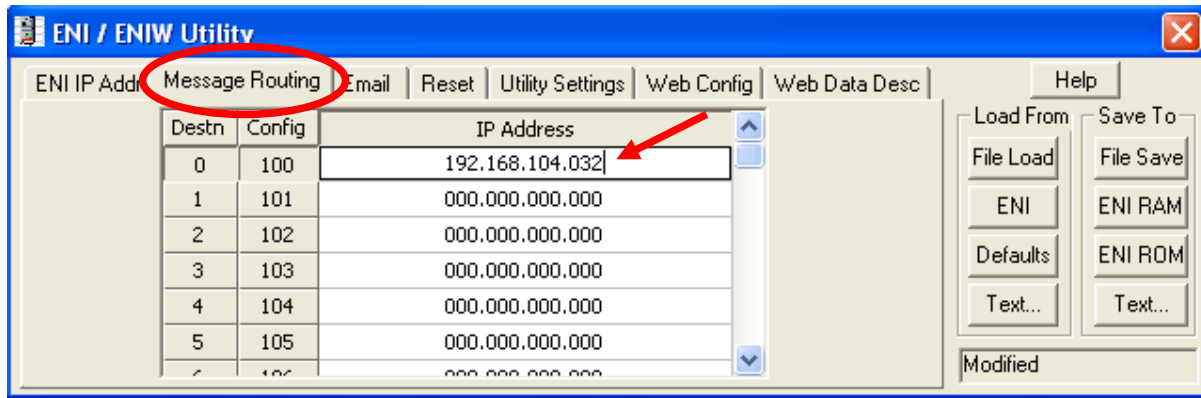

6. Select “Utility Settings” (tab), enter the COM Port # you are using and Baud Rate (38400 is ok). Leave other settings as shown.

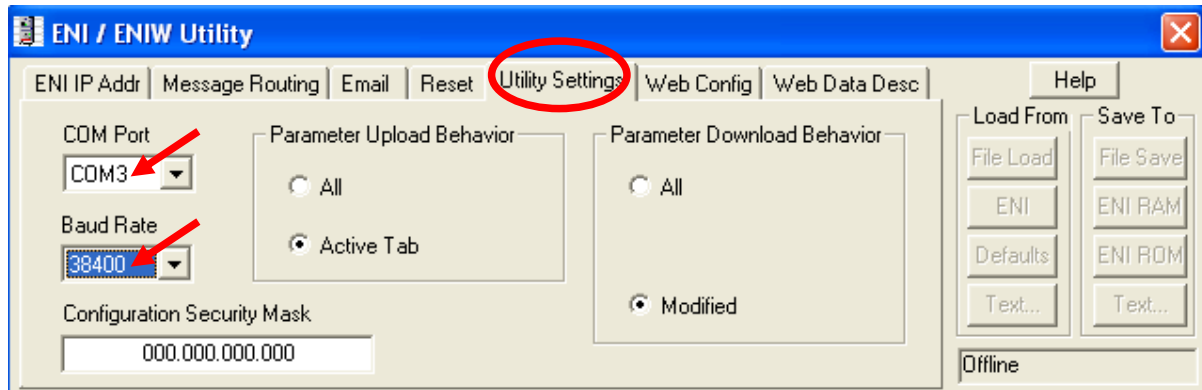

7. Last, select “ENI IP Addr” tab , again. Then, under Save To , select ENI ROM to download all settings to Interface Module.

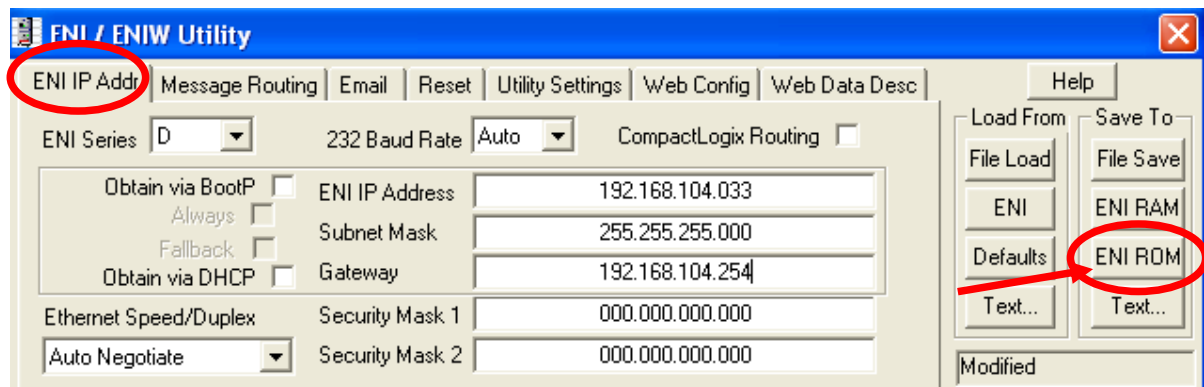

11. Once the settings are downloaded to the Interface Module, you may disconnect the programming cable and connect the cable (1761-CBL-AM00) from the Micrologix RS232 port to the Interface/Converter Module (RS232 port). Connect the Ethernet cable into Ethernet Port. Then set the switch to “Cable”.

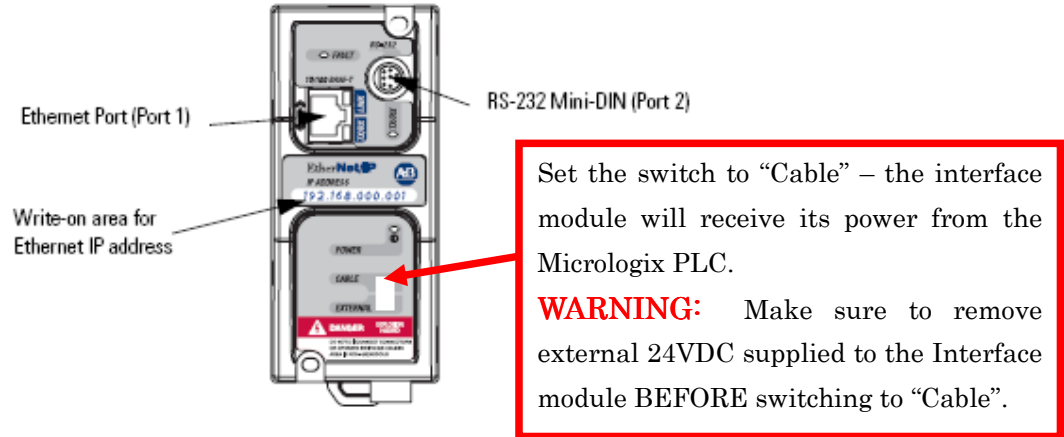

12. Connect the Interface Module and MicrO/I (Idec Touchscreen) to a network (as shown).

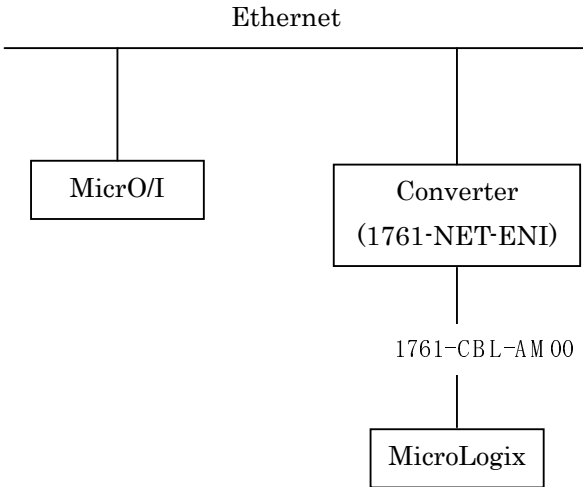

Step.2: Configure the Idec Touchscreen (10.4” TFT screen)

1. Connect programming cable(HG9Z-XCM1A) to programming port of Idec Touchscreen for local programming.
2. Launch WindO/I-NV2 Ver. 3.01.
3. Create a File name then click Next to continue.

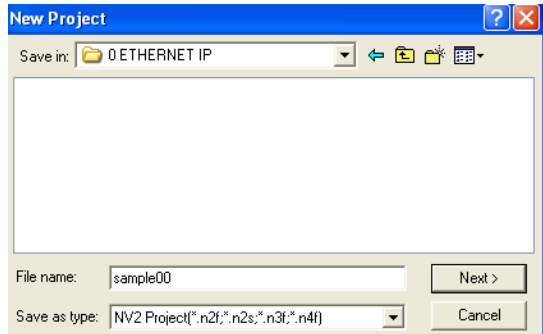

4. Select the O/I and Model type. Click Next to continue.

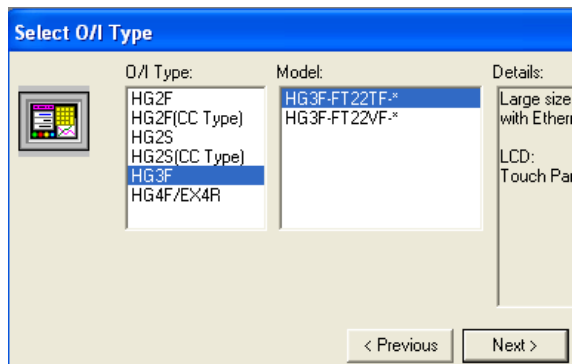

5. Select the Host I/F Driver: Allen Bradley, Ethernet/IP
Click Next to continue.

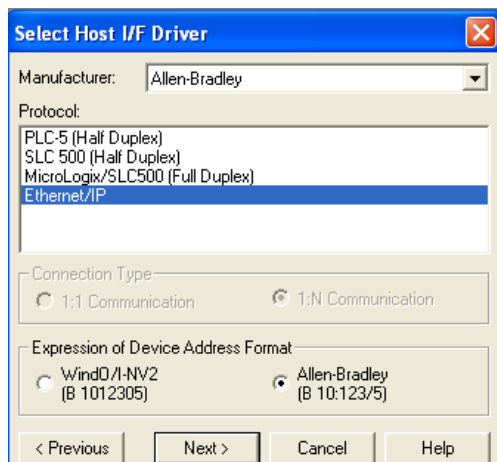

- In the Project Settings, select Communication Interface tab.
Set the IP Address as shown:

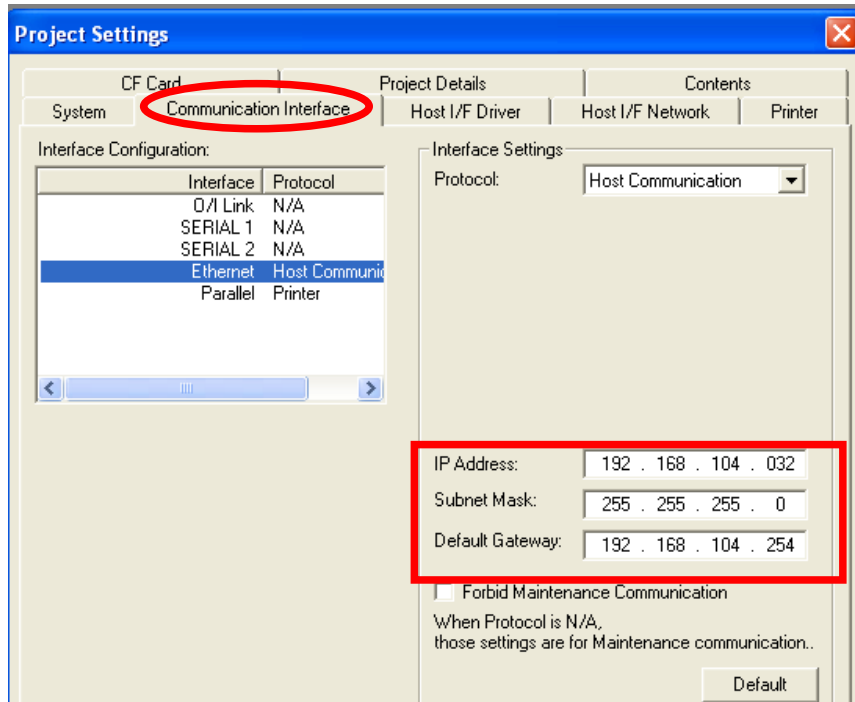

- Select "Host I/F Network" tab. Enter the Micrologix IP Address (as shown).
The Station# is set to "0" (according to Micrologix device#). Port No. leave as is. Product is Micrologix (as used in this example).

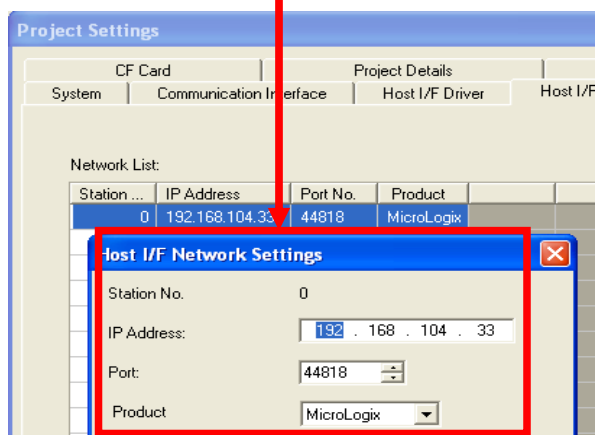
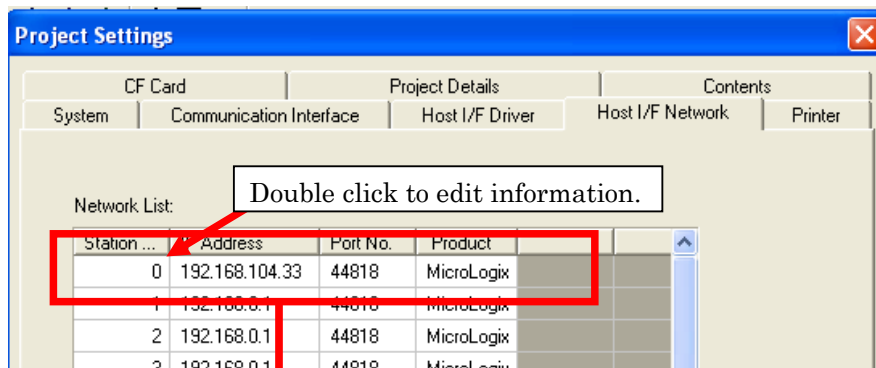

Click OK to continue and exit Project Settings.

8. To TEST the communication between two devices over the Ethernet network, select “Numerical Display” on the Base Screen.

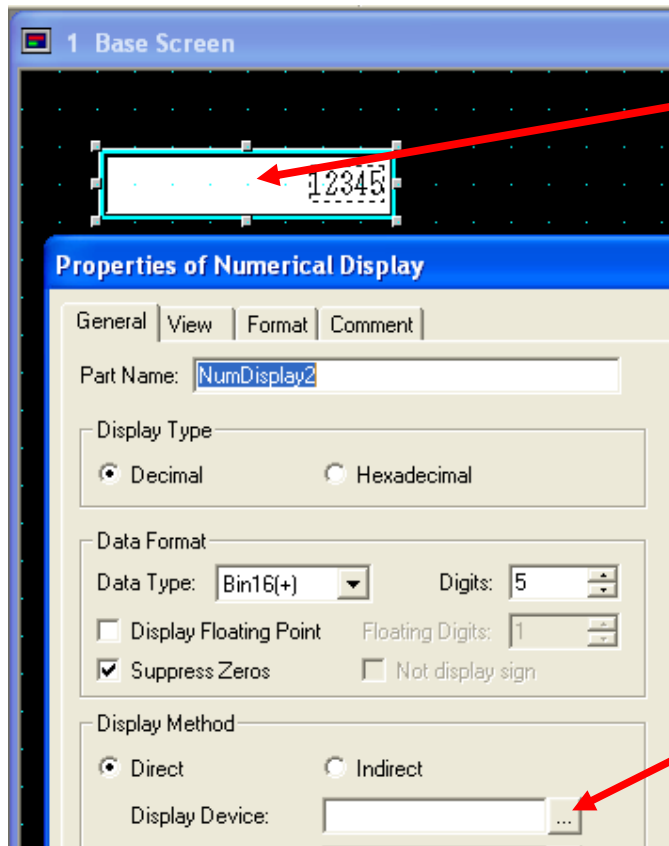

- 1) Select Numerical Display & drop on the base screen.
- 2) Double click Numerical Display to configure the Properties.
- 3) In Display Device, click the right button to show Devices.

Click this button to open Device Browser.

9. In Device Browser, select N: Integer, Address: 7:0, Station No.: 0 (Micrologix is assigned as “0”) then click Select button to use the device.

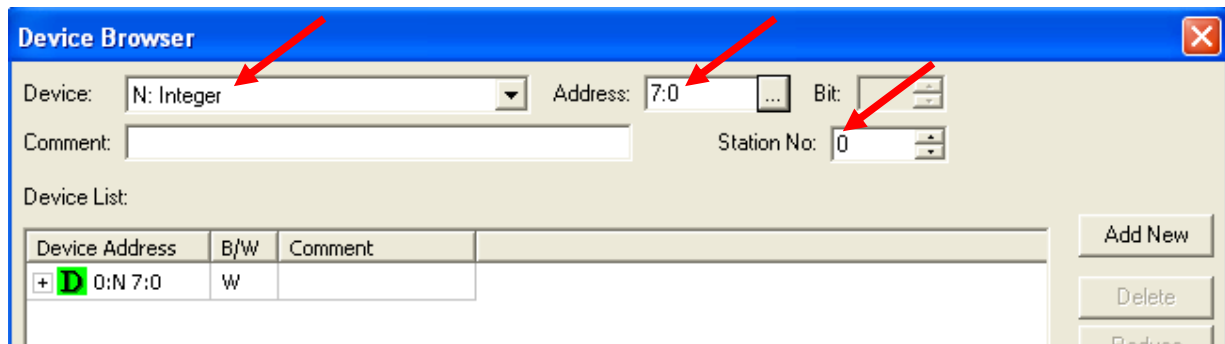

10. Download the entire project by selecting Online-Download (in WindO/I-NV2, Ver. 3.01).
11. Now, you should see the data displayed in Numerical display if communication settings are correct.

